



Workshop Manual Industriemotor 2009 ➤

4-cylinder diesel engine (2.0 l engine, common rail)									
Edition 09.2009									
Engine code	CJDA								



Contents

00 – Technical data	1
1 Technical data	1
1.1 Engine number	1
1.2 Engine data	1
01 – Self-diagnosis	2
1 Self-diagnosis	2
1.1 Features of self-diagnosis	2
1.2 Technical data of self-diagnosis	3
1.3 Connecting vehicle diagnosis, testing and information system and selecting engine control unit	3
1.4 Connecting test box to check wiring	5
2 Fault memory	7
2.1 Reading fault memory	7
2.2 Clearing fault memory	8
3 Fault table	8
3.1 Fault code: 00022/P0016...00146/P0092	9
3.2 Fault code: 00257/P0101...01687/P0697	12
3.3 Fault code: 04197/P1065...05784/P1698	30
3.4 Fault code: 08194/P2002...09780/P2634	36
3.5 Fault code: 12259/P3007...13093/P3325	45
3.6 Fault code: 49153/U0001...54282/U140A	47
4 Final control diagnosis	47
4.1 Performing final control diagnosis	47
5 Data blocks	51
5.1 Safety precautions	52
5.2 Reading data block	52
5.3 Evaluating data blocks at idling speed	53
5.4 Evaluating data blocks at full load/throttle	65
10 – Removing and installing engine	70
1 Removing and installing engine	70
1.1 Notes on removing	71
1.2 Securing engine to assembly stand	72
1.3 Notes on installing	72
1.4 Specified torques	73
1.5 Additional information and assembly work for assemblies with an air conditioner	73
13 – Crankshaft group	74
1 Dismantling and assembling engine	74
1.1 Assembly overview - poly V-belt drive	75
1.2 Removing and installing poly V-belt	76
1.3 Poly V-belt routing	77
1.4 Poly V-belt has been checked	77
1.5 Removing and installing poly V-belt tensioner	77
1.6 Removing and installing ancillaries bracket	78
1.7 Assembly overview - toothed belt drive	80



1.8	Assembly overview - crankcase	83
2	Removing and installing sealing flange and flywheel	84
2.1	Assembly overview - sealing flange and flywheel	85
2.2	Renewing crankshaft oil seal on belt pulley end	86
2.3	Removing and installing crankshaft sealing flange - belt pulley end	88
2.4	Renewing crankshaft sealing flange - flywheel end	90
2.5	Removing and installing engine speed sender -G28-	97
3	Removing and installing crankshaft	98
3.1	Assembly overview - crankshaft	99
3.2	Crankshaft dimensions	99
3.3	Pulling needle bearing out of and driving into crankshaft (when installed)	100
4	Dismantling and assembling pistons and conrods	101
4.1	Assembly overview - pistons and conrods	102
4.2	Separating new conrods	105
4.3	Bearing shells - installation position	106
4.4	Checking piston projection at TDC	106
4.5	Piston and cylinder dimensions	107
15	Cylinder head, valve gear	108
1	Cylinder head	108
1.1	Assembly overview - cylinder head	109
1.2	Removing and installing Hall sender -G40-	110
1.3	Assembly overview - cylinder head cover	113
1.4	Removing and installing cylinder head cover	114
1.5	Removing, installing and tensioning toothed belt	117
1.6	Removing and installing cylinder head	123
1.7	Removing and installing vacuum pump	130
1.8	Checking compression	131
2	Repairing valve gear	132
2.1	Assembly overview - valve gear	133
2.2	Valves	134
2.3	Renewing valve stem seals	135
2.4	Removing and installing camshaft	138
2.5	Removing and installing camshaft oil seal	144
17	Lubrication	146
1	Engine oil	146
1.1	Oil capacities	146
1.2	Engine oil specifications	146
1.3	Checking engine oil level	146
2	Parts of lubrication system	146
2.1	Assembly overview - oil pump, sump	147
2.2	Removing and installing sump	149
3	Oil filter bracket, oil pressure and oil cooler	151
3.1	Assembly overview - oil filter bracket and oil cooler	152
3.2	Checking oil pressure and oil pressure switch -F1-	153
19	Cooling	155
1	Removing and installing parts of cooling system	155



1.1	Parts of cooling system - engine side	156
1.2	Coolant hose schematic diagram diagram	157
1.3	Draining and filling coolant	159
1.4	Removing and installing coolant pump	162
1.5	Removing and installing thermostat	164
1.6	Removing and installing 4/2-way valve with thermostat	166
1.7	Checking cooling system for leaks	168
1.8	Checking oil cooler for leaks	170
20	Fuel supply system	172
1	Removing and installing parts of fuel supply system	172
1.1	Safety precautions when working on fuel supply system	172
1.2	Rules for cleanliness	173
1.3	Assembly overview - fuel filter	173
1.4	Removing and installing upper part of fuel filter	175
1.5	Removing and installing supplementary fuel pump -V393- (Inline EKP)	177
2	Checking components and functions	178
2.1	Checking supplementary fuel pump -V393- (inline electronic fuel pump)	179
2.2	Checking accelerator position sender -G79- (when fitted)	180
21	Turbocharging/supercharging	183
1	Charge air system with turbocharger	183
1.1	Safety precautions when working on charge air system with turbocharger	183
1.2	Rules for cleanliness	183
1.3	Assembly overview - turbocharger with attachments	184
1.4	Removing and installing turbocharger	186
2	Checking charge pressure system	188
2.1	Installing hose connections with connector couplings	188
2.2	Checking charge air system for leaks	190
2.3	Checking charge pressure control	192
2.4	Schematic diagram of vacuum hoses	194
2.5	Testing vacuum system	195
3	Checking components and functions	197
3.1	Check charge pressure control solenoid valve -N75-	197
3.2	Checking charge air pressure sender -G31-	199
3.3	Checking position sender for charge pressure positioner -G581-	202
3.4	Checking exhaust gas temperature sender 1 -G235- (exhaust gas temperature sender before turbocharger)	204
23	Mixture preparation - injection	207
1	Repairing diesel direct injection system	207
1.1	Safety precautions when working on diesel direct injection fuel system	208
1.2	Rules for cleanliness	208
1.3	Assembly overview - intake manifold with attachments	209
1.4	System layout	211
1.5	Assembly overview - fuel system	213
1.6	Removing and installing injector (piezo injector)	216
1.7	Checking return flow rate from fuel pressure regulating valve -N276-	220
1.8	Removing and installing fuel pressure regulating valve -N276-	221



1.9	Removing and installing fuel pressure sender -G247-	222
1.10	Removing and installing high-pressure pump	224
1.11	Filling/bleeding fuel system	226
1.12	Checking fuel system for leaks	227
1.13	Checking pressure retention valve in fuel return line	228
2	Checking components and functions	229
2.1	Checking fuel metering valve -N290-	229
2.2	Checking fuel pressure regulating valve -N276-	232
2.3	Checking fuel pressure sender -G247-	235
2.4	Checking Injectors (cylinders 1...4) -N30...N33-	241
2.5	Checking engine speed sender -G28-	242
2.6	Checking Hall sender -G40-	245
2.7	Checking intake air temperature sender -G42-	246
2.8	Checking coolant temperature sender -G62-	249
2.9	Checking fuel temperature sender -G81-	251
2.10	Checking air mass meter -G70-	253
2.11	Checking throttle valve module -J338-	255
3	Engine control unit -J623-	257
3.1	Checking voltage supply for engine control unit	257
3.2	Renewing engine control unit	259
3.3	Adapting exhaust gas pressure sensor 1 -G450-	260
3.4	Reading comparison values for amount injected (IDC/IVC) and writing to engine control unit	261
3.5	Adapting engine control unit -J623- to position sender for charge pressure positioner -G581-	262
3.6	Adapting engine control unit -J623- to exhaust gas recirculation valve	263
3.7	Adapting engine control unit -J623- to throttle valve module -J338-	264
3.8	Checking data bus	264
26	Exhaust system	266
1	Removing and installing parts of exhaust system	266
1.1	Assembly overview - particulate filter	266
2	Exhaust gas recirculation system	267
2.1	Assembly overview - exhaust gas recirculation cooler	267
3	Checking components and functions	268
3.1	Checking exhaust gas recirculation	269
3.2	Checking exhaust gas recirculation valve -N18-	270
3.3	Checking Lambda probe -G39-	272
3.4	Checking Lambda probe heater -Z19-	274
3.5	Checking exhaust gas temperature sender 3 -G495- (exhaust gas temperature sender before particulate filter)	275
3.6	Checking exhaust gas temperature sender 4 -G648- (exhaust gas temperature sender after particulate filter)	277
3.7	Checking exhaust gas pressure sensor 1 -G450-	280
3.8	Checking particulate filter	282
27	Starter, voltage supply	288
1	Starter -B-	288
1.1	Wiring connections on solenoid switch	288
1.2	Starter -B- does not turn over	288



1.3	Starter -B- turns over too slowly and does not turn engine over	289
1.4	Removing and installing starter -B-	290
2	Alternator -C-	292
2.1	Assembly overview - alternator -C-	292
2.2	Checking alternator -C- and voltage regulator -C1-	294
2.3	Removing and installing alternator -C-	295
2.4	Removing and installing voltage regulator -C1-	297
2.5	Removing and installing poly V-belt pulley	300
2.6	Checking function of free-wheel coupling	304
3	Current flow diagrams	305
3.1	Current flow diagrams: Emission standard (97/68)	306
3.2	Current flow diagrams: Engine code CJDA (EU 5)	320
28	Glow plug system	338
1	Glow plug system	338
1.1	Removing and installing, checking glow plugs	338





00 – Technical data

1 Technical data

Engine number ⇒ [page 1](#)

Engine data ⇒ [page 1](#).

1.1 Engine number

The engine number (“code letters” and “serial number”) is located on the joint -arrow-.

Additionally there is a sticker on the toothed belt guard with “engine code” and “serial number”.

The engine number consists of up to nine characters (alpha-numeric). The first part (maximum 3 characters) makes up the “engine code”, and the second part (6 characters), the “serial number”. If more than 999999 engines with the same engine code are produced, the first of the six characters is replaced with a letter.

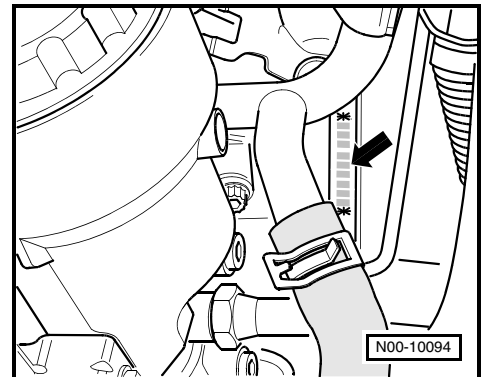

1.2 Engine data

Engine code		CJDA
Manufactured		07.09 >
Capacity	l	2,0
Output	kW at rpm	75/3000
Torque	Nm at rpm	285/1750
Bore	∅ mm	81,0
Stroke	mm	95,5
Compression ratio		16,5
CN	at least	51
Valves per cylinder		4
Firing order		1-3-4-2
Emissions fulfil		EEC Euro 5
Particulate filter		yes
Exhaust gas recirculation		yes
Turbocharging/supercharging		yes
Charge air cooler		yes



01 – Self-diagnosis

1 Self-diagnosis

Note

- ♦ Various power rating data for the engine is possible depending on the coding of the engine control unit -J623-.
- ♦ The engine control unit -J623- must be coded accordingly when taking engine into service.

Features of self-diagnosis ⇒ [page 2](#).

Technical data of self-diagnosis ⇒ [page 3](#).

Connect vehicle diagnosis, testing and information system and select engine control unit ⇒ [page 3](#).

Connect test box to check wiring ⇒ [page 5](#).

1.1 Features of self-diagnosis

The engine control unit -J623- is equipped with a fault memory.

If faults occur in the sensors and components being monitored, they will be stored in the fault memory together with an indication of the type of fault.

After evaluating the information the engine control unit decides between the different fault codes ⇒ [page 8](#) and stores these until the contents of the fault memory is cleared.

Faults which only occur sporadically are indicated as “sporadic fault” “/SP” on the print out. The cause of sporadic faults can be e.g. a loose contact or a brief open circuit. If a sporadic fault does not occur again within 50 engine starts, it will be erased from the fault memory.

If faults are recognised which affect the driving behaviour, the glow period warning lamp -K29- and/or the exhaust gas warning lamp -K83- light up.

The stored faults can also be read with the vehicle diagnosis, testing and information system -VAS 5051- ⇒ [page 7](#).

The fault memory must be erased after the faults have been eliminated ⇒ [page 8](#).

Note

General information for self-diagnosis is located in the vehicle diagnosis, testing and information system -VAS 5051- instruction manual.



1.2 Technical data of self-diagnosis

1.2.1 Reading engine control unit version

The control unit version and the coding are displayed when the vehicle diagnosis, testing and information system -VAS 5051- is connected and vehicle system "001-Engine electronics" is selected ⇒ [page 3](#).

1.2.2 Diagnosis functions which can be selected using vehicle diagnosis, testing and information system.



Note

The prerequisites for selecting the desired diagnosis functions can be determined from the following table.

Diagnosis functions	Prerequisite		
	Engine stationary, ignition switched on	Engine running at idling speed	Engine under load
001-Identification (Read control unit version)	yes	yes	yes
004-Fault memory contents	yes ¹⁾	yes	yes
005-Final control diagnosis	yes	yes	no
007-Coding	yes	no	no
011-Measured values	yes	yes	yes
014-Extended adaption	yes	yes	no
015-Access authorization	yes	yes	no

¹⁾ Only carry out with ignition switched on, when engine does not start.

1.3 Connecting vehicle diagnosis, testing and information system and selecting engine control unit



Note

- ◆ Other diagnosis testers can be used instead of the vehicle diagnosis, testing and information system.
- ◆ For a detailed description of the design, procedures and operation of the vehicle diagnosis, testing and information system -VAS 5051-, ⇒ *Operating instructions for vehicle diagnosis, testing and information system VAS 5051*



Special tools and workshop equipment required

- ◆ Vehicle diagnosis, testing and information system -VAS 5051- with diagnosis cable -VAS 5051/6A-

Prerequisites

- Fuses must be OK.
- The battery voltage must be at least 11.5 V.
- All electrical consumers must be switched off.
- Earth connection OK.

Procedure

- Plug in connector of diagnosis cable -VAS 5051/6A- at diagnostic connection.
- Depending on the function required:
 - ◆ Switch on ignition or
 - ◆ start engine ⇒ [page 3](#), selecting diagnosis functions.



Note

- ◆ *If the display remains blank, check voltage supply for diagnostic connector referring to current flow diagram: ⇒ [page 305](#).*
- ◆ *If the indications shown during the work sequence are not shown on the display: ⇒ Operating instructions for Vehicle Diagnosis, Testing and Information System VAS 5051.*

Select operating mode

- Press key on display for “Vehicle self-diagnosis”.

Select vehicle system

- Press key “01 - Engine electronics” on display.

The control unit identification and coding of the engine control unit are shown on the display.

If the coding differs from the respective codes:

- Check control unit coding.

Select diagnostic function

All the available diagnosis functions are shown on the display.

- Press key on display for the desired function.



Note

The display fields will be displayed from top to bottom in function “011-Measured values”.

Functions which can be selected using vehicle diagnosis, testing and information system ⇒ [page 3](#).

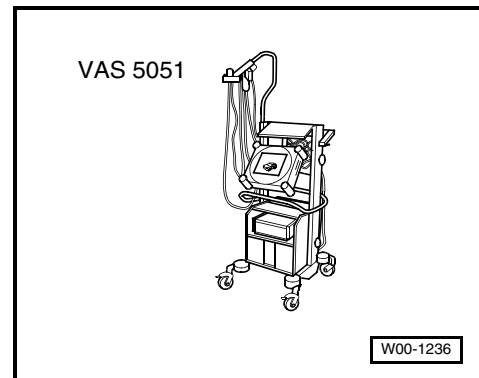



1.4 Connecting test box to check wiring

Note

- ◆ The adapter cables -V.A.G 1598/39-1- and -V.A.G 1598/39-2- are used in conjunction with the test box -V.A.G 1598/42- to check the wiring between the respective components and the engine control unit.
- ◆ The contacts on the engine control unit are distributed over two different wiring harnesses.
- ◆ Depending on the component to be tested, either the 60-pin or the 94-pin wiring harness must be checked when checking wiring.

Connect test box -V.A.G 1598/42- with:

- ◆ adapter cable -V.A.G 1598/39-1- ⇒ [page 5](#),
- ◆ adapter cable -V.A.G 1598/39-2- ⇒ [page 6](#).

1.4.1 Connecting test box -V.A.G 1598/42- with adapter cable -V.A.G 1598/39-1-

Special tools and workshop equipment required

- ◆ Test box -V.A.G 1598/42-

- ◆ Adapter cable -V.A.G 1598/39-1-

Prerequisites

- Ignition switched off
- All electrical consumers must be switched off.

Procedure

- Pull 60-pin connector off engine control unit -J623-

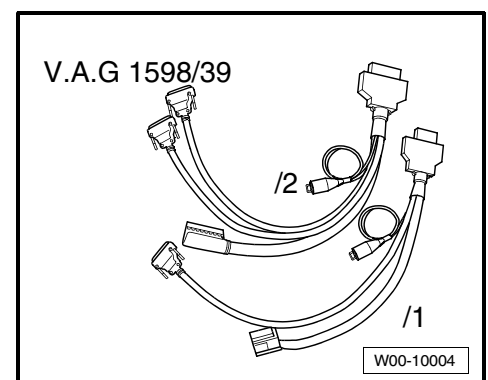
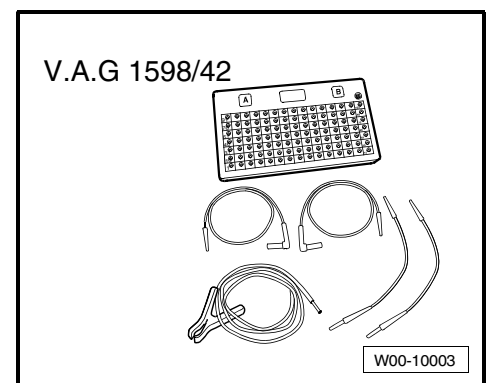



- Using adapter cable -V.A.G 1598/39-1-, connect test box -V.A.G 1598/42- to control unit wiring harness and to -connection A- on test box. The engine control unit is not connected by this action.

1.4.2 Connecting test box -V.A.G 1598/42- with adapter cable -V.A.G 1598/39-2-

Special tools and workshop equipment required

- ◆ Test box -V.A.G 1598/42-

- ◆ Adapter cable -V.A.G 1598/39-2-

Prerequisites

- Ignition switched off
- All electrical consumers must be switched off.

Procedure

- Pull 94-pin connector off engine control unit -J623-.

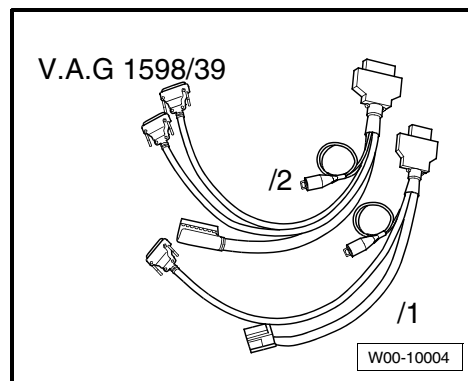
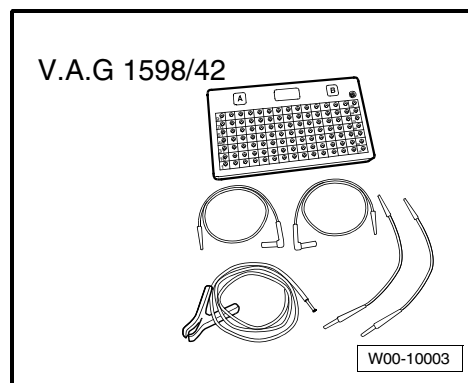
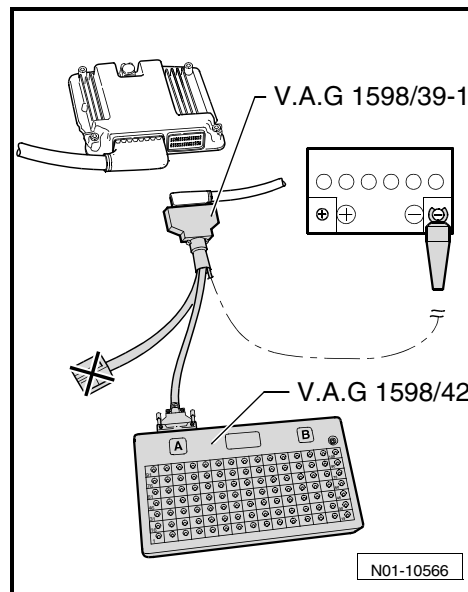



- Using adapter cable -V.A.G 1598/39-2-, connect test box -V.A.G 1598/42- to control unit wiring harness and to -connection A and B- on test box. The engine control unit is not connected by this action.

2 Fault memory

Read fault memory ⇒ [page 7](#).

Clear fault memory ⇒ [page 8](#).

2.1 Reading fault memory

Special tools and workshop equipment required

- ♦ Vehicle diagnosis, testing and information system -VAS 5051- with diagnosis cable -VAS 5051/6A-



Note

Other diagnosis testers can be used instead of the vehicle diagnosis, testing and information system.

Procedure

- Connect vehicle diagnosis, testing and information system -VAS 5051- and select diagnosis function "004-Fault memory contents". the engine must be idling when doing so. (Connect vehicle diagnosis, testing and information system and select engine control unit ⇒ [page 3](#)).
- Select the diagnostic function "004.01-Read fault memory".

Only when engine does not start: - Switch on ignition.

- If no fault is stored in engine control unit, "0 fault(s) detected" is displayed.
- If faults are stored in the engine control unit, these are shown one below the other on the display.
- Terminate diagnosis function.
- Switch off ignition.
- Rectify faults referring to fault table (⇒ [page 8](#)) as necessary, then clear fault memory ⇒ [page 8](#).

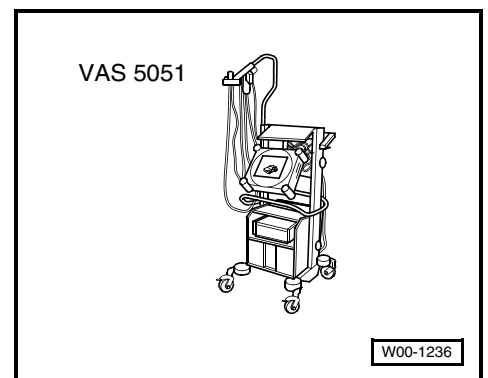
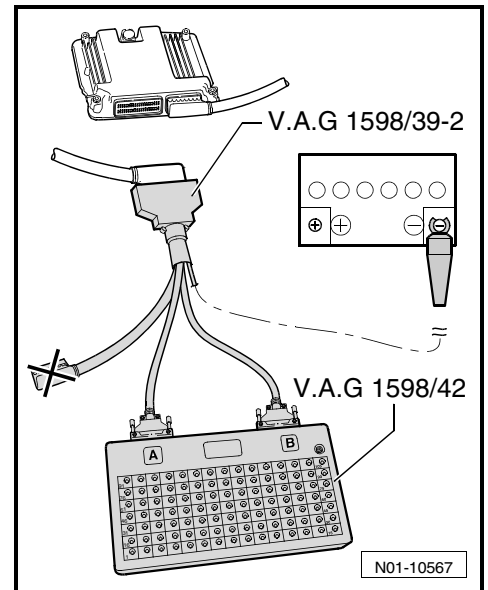



2.2 Clearing fault memory

Special tools and workshop equipment required

- ◆ Vehicle diagnosis, testing and information system -VAS 5051- with diagnosis cable -VAS 5051/6A-

Note

Other diagnosis testers can be used instead of the vehicle diagnosis, testing and information system.

Conditions

- Fault eliminated

Procedure

Note

After eliminating faults the fault memory must be read again as follows and then cleared.

- Connect vehicle diagnosis, testing and information system -VAS 5051- and select diagnosis function "004-Fault memory contents". the engine must be idling when doing so. (Connect vehicle diagnosis, testing and information system and select engine control unit ⇒ [page 3](#)).
- Select diagnosis function "004.10-Erase fault memory".

Note

If the fault memory will not erase there is a fault still in the system and this must be rectified.

- Terminate diagnosis function.
- Switch off ignition.

3 Fault table

Note

- ◆ *The fault table is listed in ascending order according to the 5-digit V.A.G. fault code on the left.*
- ◆ *So-called P codes, e.g. P0118, are also output.*
- ◆ *For explanation of fault types (e.g. "open circuit/short circuit to earth"): ⇒ Operating instructions for Vehicle Diagnosis, Testing and Information System VAS 5051.*
- ◆ *If components as shown as faulty. First check the wiring and connections to these components as well as the system earth wiring referring to current flow diagram. Only when no fault can be located here should the component be renewed. This is particularly relevant if faults are output as "sporadic" (SP).*
- ◆ *The fault memory must be cleared after rectifying existing faults ⇒ [page 8](#).*

Indicated on display, e.g.:

00280/P0118 035

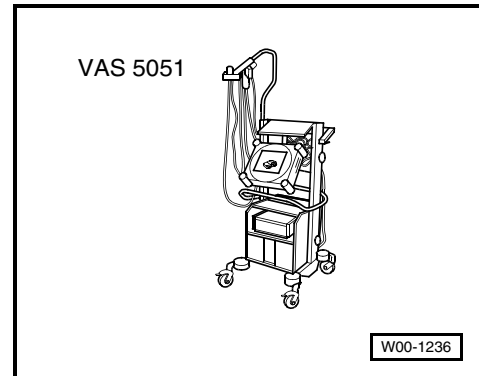



Coolant temperature sender -G62-

Signal too large

Sporadic fault



Note

- ◆ 00280 = Fault code
- ◆ P0118 = Additional fault code
- ◆ Coolant temperature sender -G62- = faulty current path or fault location
- ◆ Signal too high = Fault type as text
- ◆ Sporadic faults = Faults that are not always present e.g. loose contact

Fault code:

- ◆ 00022/P0016...00146/P0092 ⇒ page 9,
- ◆ 00257/P0101...01687/P0697 ⇒ page 12,
- ◆ 04197/P1065...05784/P1698 ⇒ page 30,
- ◆ 08194/P2002...09780/P2634 ⇒ page 36,
- ◆ 12259/P3007...13093/P3325 ⇒ page 45,
- ◆ 49153/U0001...54282/U140A ⇒ page 47.

3.1 Fault code: 00022/P0016...00146/P0092

Indicated on display	Possible cause of fault	Possible effects	Fault remedy
00022/P0016 Bank 1, camshaft position sender -G40/crankshaft position sensor - G28 Wrong allocation	<ul style="list-style-type: none"> ◆ Wiring open or short circuit ◆ -G28- defective ◆ -G40- defective ◆ Camshaft timing not OK ◆ Oil pressure too low ◆ Camshaft sender wheel defective 	<ul style="list-style-type: none"> ◆ Glow period warning lamp -K29- lights up ◆ Reduced performance ◆ Increased exhaust emissions ◆ Engine idling speed runs rough 	<ul style="list-style-type: none"> - -G28- Check. ⇒ page 242 - -G40- Check. ⇒ page 245 - Check timing ⇒ page 117, Removing, installing and tensioning toothed belt - Checking oil pressure ⇒ page 153 - Checking camshaft sender wheel ⇒ page 80
00069/P0045 Charge pressure control valve, bank 1			



Indicated on display	Possible cause of fault	Possible effects	Fault remedy
Open circuit	<ul style="list-style-type: none"> ◆ Wiring open circuit ◆ -N75- defective 	<ul style="list-style-type: none"> ◆ Glow period warning lamp -K29- lights up ◆ Exhaust gas warning lamp -K83- lights up ◆ Reduced performance ◆ Increased exhaust emissions 	– Check -N75- ⇒ page 47 , Final control diagnosis
00071/P0047 Charge pressure control valve, bank 1 Short to earth	<ul style="list-style-type: none"> ◆ Wiring short to earth ◆ -N75- defective 	<ul style="list-style-type: none"> ◆ Glow period warning lamp -K29- lights up ◆ Exhaust gas warning lamp -K83- lights up ◆ Reduced performance ◆ Increased exhaust emissions 	– Check -N75- ⇒ page 47 , Final control diagnosis
00072/P0048 Charge pressure control valve, bank 1 Short to positive	<ul style="list-style-type: none"> ◆ Wiring short to positive ◆ -N75- defective 	<ul style="list-style-type: none"> ◆ Glow period warning lamp -K29- lights up ◆ Exhaust gas warning lamp -K83- lights up ◆ Reduced performance ◆ Increased exhaust emissions 	– Check -N75- ⇒ page 47 , Final control diagnosis
00135/P0087 Fuel rail pressure/system pressure			



Indicated on display	Possible cause of fault	Possible effects	Fault remedy
Too low	<ul style="list-style-type: none"> ◆ Fuel level too low ◆ Fuel system leaking ◆ Fault in low-pressure fuel system ◆ Fault in high-pressure fuel system ◆ Metering unit defective. 	<ul style="list-style-type: none"> ◆ Glow period warning lamp -K29- lights up ◆ Exhaust gas warning lamp -K83- lights up ◆ Reduced performance ◆ Increased exhaust emissions 	<ul style="list-style-type: none"> – Check fuel level in fuel tank – Checking fuel system for leaks ⇒ page 227 – Check supplementary fuel pump -V393- ⇒ page 47, final control diagnosis – Check fuel pressure regulating valve -N276- ⇒ page 232. – Check fuel pressure regulating valve -N276- ⇒ page 220 – Check fuel pressure sender -G247- ⇒ page 235 – Checking fuel metering valve -N290- ⇒ page 229
00136/P0088 Fuel rail pressure/system pressure Too high	<ul style="list-style-type: none"> ◆ Fuel level too low ◆ Fuel system leaking ◆ Fault in low-pressure fuel system ◆ Fault in high-pressure fuel system ◆ Metering unit defective. 	<ul style="list-style-type: none"> ◆ Glow period warning lamp -K29- lights up ◆ Exhaust gas warning lamp -K83- lights up ◆ Reduced performance ◆ Increased exhaust emissions 	<ul style="list-style-type: none"> – Check fuel level in fuel tank – Checking fuel system for leaks ⇒ page 227 – Check supplementary fuel pump -V393- ⇒ page 47, final control diagnosis – Check fuel pressure regulating valve -N276- ⇒ page 232. – Check fuel pressure regulating valve -N276- ⇒ page 220 – Check fuel pressure sender -G247- ⇒ page 235 – Checking fuel metering valve -N290- ⇒ page 229
00144/P0090 Fuel metering valve -N290-			



Indicated on display	Possible cause of fault	Possible effects	Fault remedy
Electrical fault	<ul style="list-style-type: none"> ◆ Wiring open or short circuit ◆ -N290- defective 	<ul style="list-style-type: none"> ◆ Glow period warning lamp -K29- lights up ◆ Exhaust gas warning lamp -K83- lights up 	– Checking fuel metering valve -N290- ⇒ page 229
00145/P0091 Fuel metering valve -N290- Short to earth	<ul style="list-style-type: none"> ◆ Wiring short to earth ◆ -N290- defective 	<ul style="list-style-type: none"> ◆ Glow period warning lamp -K29- lights up ◆ Exhaust gas warning lamp -K83- lights up ◆ Engine will not start 	– Checking fuel metering valve -N290- ⇒ page 229
00146/P0092 Fuel metering valve -N290- Short to positive	<ul style="list-style-type: none"> ◆ Wiring short to positive ◆ -N290- defective 	<ul style="list-style-type: none"> ◆ Glow period warning lamp -K29- lights up ◆ Exhaust gas warning lamp -K83- lights up 	– Checking fuel metering valve -N290- ⇒ page 229

3.2 Fault code: 00257/P0101...01687/P0697

Indicated on display	Possible cause of fault	Possible effects	Fault remedy
00257/P0101 Air mass meter -G70- Implausible signal	<ul style="list-style-type: none"> ◆ Wiring open or short circuit ◆ -G70- defective 	<ul style="list-style-type: none"> ◆ Glow period warning lamp -K29- lights up ◆ Exhaust gas warning lamp -K83- lights up ◆ Reduced performance ◆ Increased exhaust emissions ◆ Smoke formation ◆ Possibly no regeneration of particulate filter 	– -G70- Check. ⇒ page 253
00258/P0102 Air mass meter -G70-			



Indicated on display	Possible cause of fault	Possible effects	Fault remedy
Signal too low	<ul style="list-style-type: none"> ◆ Wiring open or short circuit ◆ -G70- defective 	<ul style="list-style-type: none"> ◆ Glow period warning lamp -K29- lights up ◆ Exhaust gas warning lamp -K83- lights up ◆ Possibility reduced performance ◆ Increased exhaust emissions ◆ No regeneration of particulate filter 	– -G70- Check. ⇒ page 253
00259/P0103 Air mass meter -G70- Signal too large	<ul style="list-style-type: none"> ◆ Wiring open or short circuit ◆ -G70- defective 	<ul style="list-style-type: none"> ◆ Glow period warning lamp -K29- lights up ◆ Exhaust gas warning lamp -K83- lights up ◆ Possibility reduced performance ◆ Increased exhaust emissions ◆ No regeneration of particulate filter 	– -G70- Check. ⇒ page 253
00260/P0104 Air mass meter -G70- No signal	<ul style="list-style-type: none"> ◆ Wiring open or short circuit ◆ -G70- defective 	<ul style="list-style-type: none"> ◆ Glow period warning lamp -K29- lights up ◆ Exhaust gas warning lamp -K83- lights up ◆ Possibility reduced performance ◆ Increased exhaust emissions ◆ No regeneration of particulate filter 	– -G70- Check. ⇒ page 253
00273/P0111 Intake air temperature sender -G42- Implausible signal	<ul style="list-style-type: none"> ◆ Wiring open or short circuit ◆ -G42- defective 	<ul style="list-style-type: none"> ◆ Exhaust gas warning lamp -K83- lights up 	– -G42- Check. ⇒ page 246
00274/P0112 Intake air temperature sender -G42-			



Indicated on display	Possible cause of fault	Possible effects	Fault remedy
Signal too low	<ul style="list-style-type: none"> ◆ Wiring open circuit or wiring short to positive ◆ -G42- defective 	<ul style="list-style-type: none"> ◆ Exhaust gas warning lamp -K83- lights up ◆ Reduced performance ◆ Increased exhaust emissions ◆ No regeneration of particulate filter 	<ul style="list-style-type: none"> – -G42- Check. ⇒ page 246
00275/P0113 Intake air temperature sender -G42- Signal too large	<ul style="list-style-type: none"> ◆ Wire open circuit or wire has short to earth ◆ -G42- defective 	<ul style="list-style-type: none"> ◆ Exhaust gas warning lamp -K83- lights up ◆ Reduced performance ◆ Increased exhaust emissions ◆ No regeneration of particulate filter 	<ul style="list-style-type: none"> – -G42- Check. ⇒ page 246
00278/P0116 Intake air temperature sender -G62- Implausible signal	<ul style="list-style-type: none"> ◆ Wiring open or short circuit ◆ -G62- defective 	<ul style="list-style-type: none"> ◆ Exhaust gas warning lamp -K83- lights up ◆ Reduced performance ◆ Increased exhaust emissions ◆ Possibly no regeneration of particulate filter 	<ul style="list-style-type: none"> – -G62- Check. ⇒ page 249 – Check coolant thermostat ⇒ page 156, parts of cooling system on engine side
00279/P0117 Intake air temperature sender -G62- Signal too low	<ul style="list-style-type: none"> ◆ Wiring open circuit or wiring short to positive ◆ -G62- defective 	<ul style="list-style-type: none"> ◆ Exhaust gas warning lamp -K83- lights up ◆ Increased exhaust emissions ◆ Possibly cold starting problems 	<ul style="list-style-type: none"> – -G62- Check. ⇒ page 249 – Check coolant thermostat ⇒ page 156, parts of cooling system on engine side
00280/P0118 Intake air temperature sender -G62- Signal too large	<ul style="list-style-type: none"> ◆ Wire open circuit or wire has short to earth ◆ -G62- defective 	<ul style="list-style-type: none"> ◆ Exhaust gas warning lamp -K83- lights up ◆ Increased exhaust emissions ◆ Possibly cold starting problems 	<ul style="list-style-type: none"> – -G62- Check. ⇒ page 249 – Check coolant thermostat ⇒ page 156, parts of cooling system on engine side



Indicated on display	Possible cause of fault	Possible effects	Fault remedy
00289/P0121 Throttle valve potentiometer -G69- Implausible signal	<ul style="list-style-type: none"> ◆ Wiring open or short circuit ◆ Throttle valve potentiometer -G69- defective 	<ul style="list-style-type: none"> ◆ Glow period warning lamp -K29- lights up ◆ Exhaust gas warning lamp -K83- lights up ◆ Increased exhaust emissions 	<ul style="list-style-type: none"> - Check -J338- ⇒ page 47, Final control diagnosis - -J338- Check. ⇒ page 255
00290/P0122 Throttle valve potentiometer -G69- Signal too low	<ul style="list-style-type: none"> ◆ Wiring open circuit or wiring short to positive ◆ Throttle valve potentiometer -G69- defective 	<ul style="list-style-type: none"> ◆ Glow period warning lamp -K29- lights up ◆ Exhaust gas warning lamp -K83- lights up ◆ Increased exhaust emissions ◆ No regeneration of particulate filter 	<ul style="list-style-type: none"> - Check -J338- ⇒ page 47, Final control diagnosis - -J338- Check. ⇒ page 255
00291/P0123 Throttle valve potentiometer -G69- Signal too high	<ul style="list-style-type: none"> ◆ Wire open circuit or wire has short to earth ◆ Throttle valve potentiometer -G69- defective 	<ul style="list-style-type: none"> ◆ Glow period warning lamp -K29- lights up ◆ Exhaust gas warning lamp -K83- lights up ◆ Increased exhaust emissions ◆ No regeneration of particulate filter 	<ul style="list-style-type: none"> - Check -J338- ⇒ page 47, Final control diagnosis - -J338- Check. ⇒ page 255
00304/P0130 Bank 1 - probe 1 Electrical fault in current circuit	<ul style="list-style-type: none"> ◆ Wiring open or short circuit ◆ Lambda probe -G39- defective 	<ul style="list-style-type: none"> ◆ Exhaust gas warning lamp -K83- lights up ◆ No exhaust gas control ◆ Increased exhaust emissions 	<ul style="list-style-type: none"> - -G39- Check. ⇒ page 272
00305/P0131 Bank 1 - probe 1 Voltage too low	<ul style="list-style-type: none"> ◆ Voltage supply too low ◆ Lambda probe -G39- defective 	<ul style="list-style-type: none"> ◆ Exhaust gas warning lamp -K83- lights up ◆ No exhaust gas control ◆ Increased exhaust emissions 	<ul style="list-style-type: none"> - -G39- Check. ⇒ page 272
00306/P0132 Bank 1 - probe 1			



Indicated on display	Possible cause of fault	Possible effects	Fault remedy
Voltage too great	<ul style="list-style-type: none"> ◆ Voltage supply too high ◆ Lambda probe -G39- defective 	<ul style="list-style-type: none"> ◆ Exhaust gas warning lamp -K83- lights up ◆ No exhaust gas control ◆ Increased exhaust emissions 	– -G39- Check. ⇒ page 272
00309/P0135 Bank 1 - probe 1, heater element circuit Electrical fault	<ul style="list-style-type: none"> ◆ Wiring open circuit ◆ Lambda probe heater -Z19- defective 	<ul style="list-style-type: none"> ◆ Exhaust gas warning lamp -K83- lights up ◆ No exhaust gas control ◆ Increased exhaust emissions 	– -Z19- Check. ⇒ page 274
00385/P0181 Fuel temperature sender -G81- Implausible signal	<ul style="list-style-type: none"> ◆ Wiring open or short circuit ◆ -G81- defective 	<ul style="list-style-type: none"> ◆ Exhaust gas warning lamp -K83- lights up ◆ Increased exhaust emissions 	– -G81- Check. ⇒ page 251
00386/P0182 Fuel temperature sender -G81- Short to earth	<ul style="list-style-type: none"> ◆ Wiring short to earth ◆ -G81- defective 	<ul style="list-style-type: none"> ◆ Exhaust gas warning lamp -K83- lights up ◆ Increased exhaust emissions ◆ No regeneration of particulate filter 	– -G81- Check. ⇒ page 251
00387/P0183 Fuel temperature sender -G81- Open circuit/short to positive	<ul style="list-style-type: none"> ◆ Wiring open circuit or wiring short to positive ◆ -G81- defective 	<ul style="list-style-type: none"> ◆ Exhaust gas warning lamp -K83- lights up ◆ Increased exhaust emissions ◆ No regeneration of particulate filter 	– -G81- Check. ⇒ page 251
00401/P0191 Fuel pressure sender -G247- Implausible signal	<ul style="list-style-type: none"> ◆ Wiring open or short circuit ◆ -G247- defective 	<ul style="list-style-type: none"> ◆ Exhaust gas warning lamp -K83- lights up ◆ Reduced performance ◆ Increased exhaust emissions 	– -G247- Check. ⇒ page 235



Indicated on display	Possible cause of fault	Possible effects	Fault remedy
00402/P0192 Fuel pressure sender -G247- Short to earth	<ul style="list-style-type: none"> ◆ Wire open circuit or wire has short to earth ◆ -G247- defective 	<ul style="list-style-type: none"> ◆ Glow period warning lamp -K29- lights up ◆ Exhaust gas warning lamp -K83- lights up ◆ Reduced performance ◆ Increased exhaust emissions 	<p>– -G247- Check. ⇒ page 235</p>
00403/P0193 Fuel pressure sender -G247- Short to positive	<ul style="list-style-type: none"> ◆ Wiring open circuit or wiring short to positive ◆ -G247- defective 	<ul style="list-style-type: none"> ◆ Glow period warning lamp -K29- lights up ◆ Exhaust gas warning lamp -K83- lights up ◆ Reduced performance ◆ Increased exhaust emissions 	<p>– -G247- Check. ⇒ page 235</p>
00513/P0201 Injector No. 1 cyl. -N30- Electrical fault in circuit	<ul style="list-style-type: none"> ◆ Wiring open or short circuit ◆ -N30- defective 	<ul style="list-style-type: none"> ◆ Glow period warning lamp -K29- lights up ◆ Exhaust gas warning lamp -K83- lights up ◆ Engine idling rough or engine stalls ◆ Reduced performance ◆ Increased exhaust emissions 	<p>– -N30- Check. ⇒ page 241</p>
00514/P0202 Injector No. 2 cyl. -N31- Electrical fault in circuit	<ul style="list-style-type: none"> ◆ Wiring open or short circuit ◆ -N31- defective 	<ul style="list-style-type: none"> ◆ Glow period warning lamp -K29- lights up ◆ Exhaust gas warning lamp -K83- lights up ◆ Engine idling rough or engine stalls ◆ Reduced performance ◆ Increased exhaust emissions 	<p>– -N31- Check. ⇒ page 241</p>
00515/P0203 Injector No. 3 cyl. -N32-			



Indicated on display	Possible cause of fault	Possible effects	Fault remedy
Electrical fault in circuit	<ul style="list-style-type: none"> ◆ Wiring open or short circuit ◆ -N32- defective 	<ul style="list-style-type: none"> ◆ Glow period warning lamp -K29- lights up ◆ Exhaust gas warning lamp -K83- lights up ◆ Engine idling rough or engine stalls ◆ Reduced performance ◆ Increased exhaust emissions 	<ul style="list-style-type: none"> – -N32- Check. ⇒ page 241
00516/P0204 Injector No. 4 cyl. -N33- Electrical fault in circuit	<ul style="list-style-type: none"> ◆ Wiring open or short circuit ◆ -N33- defective 	<ul style="list-style-type: none"> ◆ Glow period warning lamp -K29- lights up ◆ Exhaust gas warning lamp -K83- lights up ◆ Engine idling rough or engine stalls ◆ Reduced performance ◆ Increased exhaust emissions 	<ul style="list-style-type: none"> – -N33- Check. ⇒ page 241
00564/P0234 Charge air pressure control Control limit exceeded	<ul style="list-style-type: none"> ◆ Defective charge pressure control solenoid valve -N75- ◆ Hose connections interchanged, not connected ◆ Charge air system leaking 	<ul style="list-style-type: none"> ◆ Glow period warning lamp -K29- lights up ◆ Exhaust gas warning lamp -K83- lights up ◆ No regeneration of particulate filter ◆ Reduced performance ◆ Charge pressure too high 	<ul style="list-style-type: none"> – Check -N75- ⇒ page 47, Final control diagnosis – Checking charge pressure control ⇒ page 192. – Checking charge air system for leaks ⇒ page 190
00566/P0236 Charge pressure sender -G31- Implausible signal	<ul style="list-style-type: none"> ◆ Wire open circuit or wire has short to earth ◆ -G31- defective 	<ul style="list-style-type: none"> ◆ Glow period warning lamp -K29- lights up ◆ Exhaust gas warning lamp -K83- lights up ◆ Reduced performance 	<ul style="list-style-type: none"> – -G31- Check. ⇒ page 199 – Checking charge pressure control ⇒ page 192.
00567/P0237 Charge pressure sender -G31-			



Indicated on display	Possible cause of fault	Possible effects	Fault remedy
Signal too low	<ul style="list-style-type: none"> ◆ Wiring open or short circuit ◆ -G31- defective 	<ul style="list-style-type: none"> ◆ Glow period warning lamp -K29- lights up ◆ Exhaust gas warning lamp -K83- lights up ◆ Reduced performance ◆ No regeneration of particulate filter 	<ul style="list-style-type: none"> – -G31- Check. ⇒ page 199 – Checking charge pressure control ⇒ page 192.
00568/P0238 Charge pressure sender -G31- Signal too large	<ul style="list-style-type: none"> ◆ Wiring open or short circuit ◆ -G31- defective 	<ul style="list-style-type: none"> ◆ Glow period warning lamp -K29- lights up ◆ Exhaust gas warning lamp -K83- lights up ◆ Reduced performance ◆ No regeneration of particulate filter 	<ul style="list-style-type: none"> – -G31- Check. ⇒ page 199 – Checking charge pressure control ⇒ page 192.
00611/P0263 Deviation in quantity injected, cyl.1	<ul style="list-style-type: none"> ◆ Adaption value does not correspond with adaption value for injector 	<ul style="list-style-type: none"> ◆ Glow period warning lamp -K29- lights up ◆ Injection quantity is faulty 	<ul style="list-style-type: none"> – Check comparison values for amount injected (IDC/IVC) ⇒ page 261
00614/P0266 Deviation in quantity injected, cyl.2	<ul style="list-style-type: none"> ◆ Adaption value does not correspond with adaption value for injector 	<ul style="list-style-type: none"> ◆ Glow period warning lamp -K29- lights up ◆ Injection quantity is faulty 	<ul style="list-style-type: none"> – Check comparison values for amount injected (IDC/IVC) ⇒ page 261
00617/P0269 Deviation in quantity injected, cyl.3	<ul style="list-style-type: none"> ◆ Adaption value does not correspond with adaption value for injector 	<ul style="list-style-type: none"> ◆ Glow period warning lamp -K29- lights up ◆ Injection quantity is faulty 	<ul style="list-style-type: none"> – Check comparison values for amount injected (IDC/IVC) ⇒ page 261
00626/P0272 Deviation in quantity injected, cyl.4	<ul style="list-style-type: none"> ◆ Adaption value does not correspond with adaption value for injector 	<ul style="list-style-type: none"> ◆ Glow period warning lamp -K29- lights up ◆ Injection quantity is faulty 	<ul style="list-style-type: none"> – Check comparison values for amount injected (IDC/IVC) ⇒ page 261
00665/P0299 Charge air pressure control Control limit not reached	<ul style="list-style-type: none"> ◆ Defective charge pressure control solenoid valve -N75- ◆ Turbocharger defective ◆ Charge air system leaking 	<ul style="list-style-type: none"> ◆ Glow period warning lamp -K29- lights up ◆ Exhaust gas warning lamp -K83- lights up ◆ Reduced performance ◆ Charge pressure too low ◆ No exhaust gas control ◆ No regeneration of particulate filter 	<ul style="list-style-type: none"> – Check -N75- ⇒ page 47, Final control diagnosis – Checking charge air system for leaks ⇒ page 190 – Checking charge pressure control ⇒ page 192.



Indicated on display	Possible cause of fault	Possible effects	Fault remedy
00768/P0300 Misfiring detected	<ul style="list-style-type: none"> ◆ Poor compression values ◆ Injector cyl. 1...4 -N30...N33- defective 	<ul style="list-style-type: none"> ◆ Reduced performance ◆ Misfiring ◆ Increased exhaust emissions ◆ Engine runs rough 	<ul style="list-style-type: none"> – Check compression ⇒ page 131. – Check Injector cyl. 1...4 -N30...N33- ⇒ page 241
00769/P0301 Cyl. 1 Misfiring detected	<ul style="list-style-type: none"> ◆ Poor compression values for cylinder 1 ◆ Injector cyl. 1 -N30- defective 	<ul style="list-style-type: none"> ◆ Reduced performance ◆ Misfiring ◆ Increased exhaust emissions ◆ Engine runs rough 	<ul style="list-style-type: none"> – Check compression ⇒ page 131. – Check Injector cyl. 1 -N30- ⇒ page 241
00779/P0302 Cyl. 2 Misfiring detected	<ul style="list-style-type: none"> ◆ Poor compression values for cylinder 2 ◆ Injector cyl. 2 -N31- defective 	<ul style="list-style-type: none"> ◆ Reduced performance ◆ Misfiring ◆ Increased exhaust emissions ◆ Engine runs rough 	<ul style="list-style-type: none"> – Check compression ⇒ page 131. – Check Injector cyl. 2 -N31- ⇒ page 241
00771/P0303 Cyl. 3 Misfiring detected	<ul style="list-style-type: none"> ◆ Poor compression values for cylinder 3 ◆ Injector cyl. 3 -N32- defective 	<ul style="list-style-type: none"> ◆ Reduced performance ◆ Misfiring ◆ Increased exhaust emissions ◆ Engine runs rough 	<ul style="list-style-type: none"> – Check compression ⇒ page 131. – Check Injector cyl. 3 -N32- ⇒ page 241
00772/P0304 Cyl. 4 Misfiring detected	<ul style="list-style-type: none"> ◆ Poor compression values for cylinder 4 ◆ Injector cyl. 4 -N33- defective 	<ul style="list-style-type: none"> ◆ Reduced performance ◆ Misfiring ◆ Increased exhaust emissions ◆ Engine runs rough 	<ul style="list-style-type: none"> – Check compression ⇒ page 131. – Check Injector cyl. 4 -N33- ⇒ page 241
00801/P0321 Engine speed sender -G28- Implausible signal	<ul style="list-style-type: none"> ◆ Wire open circuit or wire has short to earth ◆ -G28- defective or loose ◆ Metal particles on engine speed sender or ◆ Gap -G28-/sender wheel too large 	<ul style="list-style-type: none"> ◆ Glow period warning lamp -K29- lights up ◆ Exhaust gas warning lamp -K83- lights up ◆ Increased exhaust emissions ◆ Engine stalls ◆ Engine runs rough ◆ Reduced performance ◆ No exhaust gas control ◆ No regeneration of particulate filter ◆ Rev. counter, possibly no display 	<ul style="list-style-type: none"> – -G28- Check. ⇒ page 242



Indicated on display	Possible cause of fault	Possible effects	Fault remedy
00802/P0322 Engine speed sender -G28- No signal	<ul style="list-style-type: none"> ◆ Wiring open or short circuit ◆ -G28- defective 	<ul style="list-style-type: none"> ◆ Glow period warning lamp -K29- lights up ◆ Exhaust gas warning lamp -K83- lights up ◆ Engine will not start ◆ Engine stalls ◆ Engine runs rough ◆ Reduced performance ◆ No exhaust gas control ◆ No regeneration of particulate filter ◆ Rev. counter no display 	<ul style="list-style-type: none"> – -G28- Check. ⇒ page 242
00833/P0341 Camshaft position sensor => sender-G40- Implausible signal	<ul style="list-style-type: none"> ◆ Wire open circuit or wire has short to earth ◆ Hall sender -G40- defective or loose ◆ Metal particles on hub or Hall sender -G40- ◆ Gap Hall sender -G40-/hub too large ◆ Hub with sender wheel on camshaft is twisted or loose 	<ul style="list-style-type: none"> ◆ Increased exhaust emissions ◆ Reduced output at full load/throttle ◆ High fuel consumption ◆ Engine starts reluctantly or not at all when cold 	<ul style="list-style-type: none"> – -G40- Check. ⇒ page 245 – Check position of camshaft and sender wheel ⇒ page 117, Removing, installing and tensioning toothed belt.
00899/P0383 Activation of glow period control unit 1 Short to earth	<ul style="list-style-type: none"> ◆ Wire open circuit or wire has short to earth ◆ Automatic glow period control unit -J179- defective 	<ul style="list-style-type: none"> ◆ Engine starts reluctantly when cold ◆ Smoke formation possible when starting engine 	<ul style="list-style-type: none"> – Check -J179- ⇒ page 47, Final control diagnosis
01024/P0400 Exhaust gas recirculation system			



Indicated on display	Possible cause of fault	Possible effects	Fault remedy
Malfunction	<ul style="list-style-type: none"> ◆ Exhaust gas recirculation system defective 	<ul style="list-style-type: none"> ◆ No exhaust gas recirculation ◆ Reduced performance ◆ Increased exhaust emissions 	<ul style="list-style-type: none"> – Check exhaust gas recirculation system ⇒ page 269
01025/P0401 Exhaust gas recirculation system Flow rate too low	<ul style="list-style-type: none"> ◆ Exhaust gas recirculation system blocked ◆ Exhaust gas recirculation system leaking 	<ul style="list-style-type: none"> ◆ Exhaust gas warning lamp -K83- lights up ◆ No exhaust gas recirculation ◆ Reduced performance ◆ Increased exhaust emissions ◆ No regeneration of particulate filter 	<ul style="list-style-type: none"> – Check exhaust gas recirculation system ⇒ page 269
01026/P0402 Exhaust gas recirculation system Flow rate too high	<ul style="list-style-type: none"> ◆ Exhaust gas recirculation system leaking 	<ul style="list-style-type: none"> ◆ Glow period warning lamp -K29- lights up ◆ Exhaust gas warning lamp -K83- lights up ◆ No exhaust gas recirculation ◆ Reduced performance ◆ Increased exhaust emissions ◆ No regeneration of particulate filter 	<ul style="list-style-type: none"> – Check exhaust gas recirculation system ⇒ page 269
01027/P0403 Exhaust gas recirculation valve -N18- Malfunction	<ul style="list-style-type: none"> ◆ -N18- defective 	<ul style="list-style-type: none"> ◆ Glow period warning lamp -K29- lights up ◆ Exhaust gas warning lamp -K83- lights up ◆ No exhaust gas recirculation ◆ Reduced performance ◆ Increased exhaust emissions ◆ No regeneration of particulate filter 	<ul style="list-style-type: none"> – Check -N18- ⇒ page 47, Final control diagnosis – Check exhaust gas recirculation system ⇒ page 269



Indicated on display	Possible cause of fault	Possible effects	Fault remedy
01029/P0405 Exhaust gas recirculation valve Signal too low	<ul style="list-style-type: none"> ◆ Wiring open circuit or wiring short to positive ◆ -G212- defective 	<ul style="list-style-type: none"> ◆ Exhaust gas warning lamp -K83- lights up ◆ No exhaust gas recirculation ◆ Reduced performance ◆ Increased exhaust emissions ◆ No regeneration of particulate filter 	<ul style="list-style-type: none"> – Check -G212- ⇒ page 270, check exhaust gas recirculation valve -N18- – Check exhaust gas recirculation system ⇒ page 269
01030/P0406 Exhaust gas recirculation valve Signal too large	<ul style="list-style-type: none"> ◆ Wire open circuit or wire has short to earth ◆ -G212- defective 	<ul style="list-style-type: none"> ◆ Exhaust gas warning lamp -K83- lights up ◆ No exhaust gas recirculation ◆ Reduced performance ◆ Increased exhaust emissions ◆ No regeneration of particulate filter 	<ul style="list-style-type: none"> – Check -G212- ⇒ page 270, check exhaust gas recirculation valve -N18- – Check exhaust gas recirculation system ⇒ page 269
01132/P046C Exhaust gas recirculation potentiometer Implausible signal	<ul style="list-style-type: none"> ◆ Wiring open or short circuit ◆ -G212- defective 	<ul style="list-style-type: none"> ◆ Exhaust gas warning lamp -K83- lights up 	<ul style="list-style-type: none"> – Check -G212- ⇒ page 270, check exhaust gas recirculation valve -N18- – Check exhaust gas recirculation system ⇒ page 269
01281/P0501 Vehicle speed signal Implausible signal	<ul style="list-style-type: none"> ◆ Wiring open or short circuit ◆ Switches or working speed governor defective 	<ul style="list-style-type: none"> ◆ Working speed governor not OK. 	<ul style="list-style-type: none"> – Check components of working speed governor ⇒ page 305, Current flow diagram
01283/P0503 Vehicle speed signal Signal too large	<ul style="list-style-type: none"> ◆ Wire open circuit or wire has short to earth ◆ Switches or working speed governor defective 	<ul style="list-style-type: none"> ◆ Working speed governor not OK. 	<ul style="list-style-type: none"> – Check components of working speed governor ⇒ page 305, Current flow diagram



Indicated on display	Possible cause of fault	Possible effects	Fault remedy
01287/P0507 Idling speed control Revs. above specification	<ul style="list-style-type: none"> ◆ Unmetered air ◆ Leaks between turbocharger and engine (charge air routing) 	<ul style="list-style-type: none"> ◆ Increased idling speed 	<ul style="list-style-type: none"> – Check intake system for leaks ⇒ page 209 – Checking charge air system for leaks ⇒ page 190
01348/P0544 Exhaust gas temperature sender 1, bank 1 Electrical fault	<ul style="list-style-type: none"> ◆ Wiring short circuit ◆ -G235- defective 	<ul style="list-style-type: none"> ◆ Glow period warning lamp -K29- lights up ◆ Exhaust gas warning lamp -K83- lights up ◆ Reduced performance ◆ Increased exhaust emissions 	<ul style="list-style-type: none"> – -G235- Check. ⇒ page 204
01349/P0545 Exhaust gas temperature sender 1, bank 1 Short to earth	<ul style="list-style-type: none"> ◆ Wiring short to earth ◆ -G235- defective 	<ul style="list-style-type: none"> ◆ Glow period warning lamp -K29- lights up ◆ Exhaust gas warning lamp -K83- lights up ◆ Reduced performance ◆ Increased exhaust emissions 	<ul style="list-style-type: none"> – -G235- Check. ⇒ page 204
01350/P0546 Exhaust gas temperature sender 1, bank 1 Short to positive	<ul style="list-style-type: none"> ◆ Wiring short to positive ◆ -G235- defective 	<ul style="list-style-type: none"> ◆ Glow period warning lamp -K29- lights up ◆ Exhaust gas warning lamp -K83- lights up ◆ Reduced performance ◆ Increased exhaust emissions 	<ul style="list-style-type: none"> – -G235- Check. ⇒ page 204
01378/P0562 Voltage supply Voltage too low	<ul style="list-style-type: none"> ◆ Voltage supply too low ◆ Defective terminal 30 voltage supply relay -J317- 	<ul style="list-style-type: none"> ◆ Engine will not start ◆ Various running problems including engine will not start 	<ul style="list-style-type: none"> – Check voltage supply for engine control unit -J623- ⇒ page 257
01393/P0571 Brake light switch -F-			



Indicated on display	Possible cause of fault	Possible effects	Fault remedy
Implausible signal	<ul style="list-style-type: none"> ◆ Wiring open or short circuit ◆ Defective brake light switch -F- ◆ Defective brake pedal switch -F47- 	<ul style="list-style-type: none"> ◆ Glow period warning lamp -K29- lights up ◆ Various running problems ◆ Brake light defective 	<ul style="list-style-type: none"> – Check -F- and -F47- ⇒ page 305, Current flow diagram
01538/P0602 Control unit programming Malfunction	<ul style="list-style-type: none"> ◆ Invalid control unit coding for engine control unit -J623- 	<ul style="list-style-type: none"> ◆ Glow period warning lamp -K29- lights up ◆ Various running problems ◆ Engine stops 	<ul style="list-style-type: none"> – Recode -J623- (according to manufacture instructions)
01541/P0605 Control unit defective	<ul style="list-style-type: none"> ◆ Engine control unit -J623-, internal defect 	<ul style="list-style-type: none"> ◆ Various running problems ◆ Engine stops 	<ul style="list-style-type: none"> – -J623- Renew. ⇒ page 259
01542/P0606 Control unit defective	<ul style="list-style-type: none"> ◆ Engine control unit -J623-, internal defect 	<ul style="list-style-type: none"> ◆ Glow period warning lamp -K29- lights up ◆ Exhaust gas warning lamp -K83- lights up ◆ Various running problems ◆ Engine stops 	<ul style="list-style-type: none"> – -J623- Renew. ⇒ page 259
01543/P0607 Control module implausible	<ul style="list-style-type: none"> ◆ Engine control unit -J623-, internal defect 	<ul style="list-style-type: none"> ◆ Exhaust gas warning lamp -K83- lights up ◆ Various running problems ◆ Engine stops 	<ul style="list-style-type: none"> – -J623- Renew. ⇒ page 259
01576/P0628 Electric fuel pump 1 relay Short to earth	<ul style="list-style-type: none"> ◆ Wire open circuit or wire has short to earth ◆ Fuel pump relay -J49- defective ◆ Engine control unit -J623- defective 	<ul style="list-style-type: none"> ◆ Glow period warning lamp -K29- lights up ◆ Exhaust gas warning lamp -K83- lights up ◆ Fuel system pressurisation pump runs permanently when ignition is on 	<ul style="list-style-type: none"> – Check -J49- ⇒ page 47, Final control diagnosis – Check wiring between -J49- and -J623- ⇒ page 305, Current flow diagram
01577/P0629 Electric fuel pump 1 relay Short to positive	<ul style="list-style-type: none"> ◆ Wiring open circuit or wiring short to positive ◆ Fuel pump relay -J49- defective ◆ Engine control unit -J623- defective 	<ul style="list-style-type: none"> ◆ Glow period warning lamp -K29- lights up ◆ Exhaust gas warning lamp -K83- lights up ◆ Engine stops 	<ul style="list-style-type: none"> – Check -J49- ⇒ page 47, Final control diagnosis – Check wiring between -J49- and -J623- ⇒ page 305, Current flow diagram



Indicated on display	Possible cause of fault	Possible effects	Fault remedy
01588/P0634 Control unit temperature shutdown	<ul style="list-style-type: none"> ◆ Output stage(s) in -J623- overloaded ◆ Ambient temperature too high ◆ Engine control unit not installed correctly ◆ Engine control unit -J623-, internal defect 	<ul style="list-style-type: none"> ◆ Glow period warning lamp -K29- lights up ◆ Exhaust gas warning lamp -K83- lights up ◆ Various running problems ◆ No exhaust gas recirculation ◆ No pre-glow system ◆ Reduced performance ◆ Increased exhaust emissions ◆ No regeneration of particulate filter ◆ Engine stops 	<ul style="list-style-type: none"> – -J623- Allow to cool and clear fault memory ⇒ page 8 – Renew -J623- if necessary ⇒ page 259
01601/P0641 Sender reference voltage "A" Open circuit	<ul style="list-style-type: none"> ◆ Wiring open or short circuit ◆ -G28- defective ◆ Hall sender -G40- defective ◆ accelerator position sender -G79- defective ◆ exhaust gas recirculation potentiometer -G212- defective ◆ Defective exhaust gas recirculation valve -N18- ◆ Position sender for charge pressure positioner -G581- defective 	<ul style="list-style-type: none"> ◆ Glow period warning lamp -K29- lights up ◆ Exhaust gas warning lamp -K83- lights up ◆ Engine stalls ◆ Engine runs rough ◆ Increased exhaust emissions ◆ Reduced performance ◆ High fuel consumption ◆ No regulation of engine revs ◆ Engine starts reluctantly or not at all when cold 	<ul style="list-style-type: none"> – -G28- Check. ⇒ page 242 – -G31- Check. ⇒ page 199 – -G79- Check. ⇒ page 180 – Check -G212-, ⇒ page 270 – Check -N18- ⇒ page 47, Final control diagnosis – -G581- Check. ⇒ page 202
01612/P064C Glow period control unit	<ul style="list-style-type: none"> ◆ Wire open circuit or wire has short to earth ◆ Incorrect automatic glow period control unit -J179- installed 	<ul style="list-style-type: none"> ◆ Glow period warning lamp -K29- lights up ◆ Engine starts reluctantly when cold ◆ Smoke formation possible when starting engine 	<ul style="list-style-type: none"> – Check -J179- ⇒ page 47, Final control diagnosis – Check that correct -J179- is installed
01617/P0651 Sender reference voltage "B"			



Indicated on display	Possible cause of fault	Possible effects	Fault remedy
Open circuit	<ul style="list-style-type: none"> ◆ Wiring open or short circuit ◆ -G28- defective ◆ Charge air pressure sender -G31- defective ◆ accelerator position sender -G79- defective ◆ exhaust gas recirculation potentiometer -G212- defective ◆ Defective exhaust gas recirculation valve -N18- ◆ Defective fuel pressure sender -G247- ◆ Position sender for charge pressure positioner -G581- defective 	<ul style="list-style-type: none"> ◆ Glow period warning lamp -K29- lights up ◆ Exhaust gas warning lamp -K83- lights up ◆ Engine stalls ◆ Engine runs rough ◆ Rev. counter no display ◆ Increased exhaust emissions ◆ Reduced performance ◆ High fuel consumption ◆ No exhaust gas recirculation ◆ No regulation of engine revs ◆ Engine starts reluctantly or not at all when cold 	<ul style="list-style-type: none"> - -G28- Check. ⇒ page 242 - -G31- Check. ⇒ page 199 - -G79- Check. ⇒ page 180 - Check -G212-, ⇒ page 270, check -N18- - Check -N18- ⇒ page 47, Final control diagnosis - -G247- Check. ⇒ page 235 - -G581- Check. ⇒ page 202
01642/P066A Glow plug, cylinder 1 Short to earth	<ul style="list-style-type: none"> ◆ Wire open circuit or wire has short to earth <p>Glow plug 1 -Q10- defective</p>	<ul style="list-style-type: none"> ◆ Engine starts reluctantly when cold 	<ul style="list-style-type: none"> - Check wiring to automatic glow period control unit -J179- ⇒ page 305, Current flow diagram.
01644/P066C Glow plug, cylinder 2 Short to earth	<ul style="list-style-type: none"> ◆ Wire open circuit or wire has short to earth <p>Glow plug 2 -Q11- defective</p>	<ul style="list-style-type: none"> ◆ Engine starts reluctantly when cold 	<ul style="list-style-type: none"> - Check wiring to automatic glow period control unit -J179- ⇒ page 305, Current flow diagram.
01646/P066E Glow plug, cylinder 3 Short to earth	<ul style="list-style-type: none"> ◆ Wire open circuit or wire has short to earth <p>Glow plug 3 -Q12- defective</p>	<ul style="list-style-type: none"> ◆ Engine starts reluctantly when cold 	<ul style="list-style-type: none"> - Check wiring to automatic glow period control unit -J179- ⇒ page 305, Current flow diagram.
01648/P0670 Glow period control unit 1 Electrical fault in current circuit	<ul style="list-style-type: none"> ◆ Wiring open or short circuit ◆ Automatic glow period control unit -J179- defective 	<ul style="list-style-type: none"> ◆ Engine starts reluctantly when cold ◆ Smoke formation possible when starting engine 	<ul style="list-style-type: none"> - Check -J179- ⇒ page 47, Final control diagnosis



Indicated on display	Possible cause of fault	Possible effects	Fault remedy
<p>01649/P0671 Glow plug, cylinder 1 -Q10-</p> <p>Electrical fault in current circuit</p>	<ul style="list-style-type: none"> ◆ Wiring open or short circuit ◆ Glow plug 1 -Q10- defective 	<ul style="list-style-type: none"> ◆ Engine starts reluctantly when cold 	<ul style="list-style-type: none"> – Check wiring to automatic glow period control unit -J179- ⇒ page 305, Current flow diagram. – Check glow plug resistance ⇒ page 338
<p>01650/P0672 Glow plug, cylinder 2 -Q11-</p> <p>Electrical fault in current circuit</p>	<ul style="list-style-type: none"> ◆ Wiring open or short circuit ◆ Glow plug 2 -Q11- defective 	<ul style="list-style-type: none"> ◆ Engine starts reluctantly when cold 	<ul style="list-style-type: none"> – Check wiring to automatic glow period control unit -J179- ⇒ page 305, Current flow diagram. – Check glow plug resistance ⇒ page 338
<p>01651/P0673 Glow plug, cylinder 3 -Q12-</p> <p>Electrical fault in current circuit</p>	<ul style="list-style-type: none"> ◆ Wiring open or short circuit ◆ Glow plug 3 -Q12- defective 	<ul style="list-style-type: none"> ◆ Engine starts reluctantly when cold 	<ul style="list-style-type: none"> – Check wiring to automatic glow period control unit -J179- ⇒ page 305, Current flow diagram. – Check glow plug resistance ⇒ page 338
<p>01652/P0674 Glow plug, cylinder 4 -Q13-</p> <p>Electrical fault in current circuit</p>	<ul style="list-style-type: none"> ◆ Wiring open or short circuit ◆ Glow plug 4 -Q13- defective 	<ul style="list-style-type: none"> ◆ Engine starts reluctantly when cold 	<ul style="list-style-type: none"> – Check wiring to automatic glow period control unit -J179- ⇒ page 305, Current flow diagram. – Check glow plug resistance ⇒ page 338
<p>01658/P067A Glow plug, cylinder 4</p>			



Indicated on display	Possible cause of fault	Possible effects	Fault remedy
Short to earth	<ul style="list-style-type: none"> ◆ Wire open circuit or wire has short to earth <p>Glow plug 4 -Q13- defective</p>	<ul style="list-style-type: none"> ◆ Engine starts reluctantly when cold 	<ul style="list-style-type: none"> – Check wiring to automatic glow period control unit -J179- ⇒ page 305, Current flow diagram. – Check glow plug resistance ⇒ page 338
01668/P0684 Glow period control unit 1 -J179- Implausible signal	<ul style="list-style-type: none"> ◆ Wiring open or short circuit ◆ Automatic glow period control unit -J179- defective 	<ul style="list-style-type: none"> ◆ Exhaust gas warning lamp -K83- lights up ◆ Engine starts reluctantly when cold 	<ul style="list-style-type: none"> – Check automatic glow period control unit -J179- ⇒ page 47, Final control diagnosis – Check wiring to automatic glow period control unit -J179- ⇒ page 305, Current flow diagram.
01674/P068A Main relay Opens too early	<ul style="list-style-type: none"> ◆ Wiring open or short circuit ◆ Terminal 30 voltage supply relay -J317- defective 	<ul style="list-style-type: none"> ◆ Exhaust gas warning lamp -K83- lights up ◆ Engine stops 	<ul style="list-style-type: none"> – Check wiring to -J317- ⇒ page 305, Current flow diagram
01675/P068B Main relay Opens too late	<ul style="list-style-type: none"> ◆ Wiring open or short circuit ◆ Terminal 30 voltage supply relay -J317- defective 	<ul style="list-style-type: none"> ◆ Exhaust gas warning lamp -K83- lights up ◆ Possible battery discharge 	<ul style="list-style-type: none"> – Check wiring to -J317- ⇒ page 305, Current flow diagram
01687/P0697 Sender reference voltage "C" Open circuit	<ul style="list-style-type: none"> ◆ Wiring open or short circuit 	<ul style="list-style-type: none"> ◆ Glow period warning lamp -K29- lights up ◆ Exhaust gas warning lamp -K83- lights up ◆ Possibility of engine stopping 	<ul style="list-style-type: none"> – -J623- Renew. ⇒ page 259



3.3 Fault code: 04197/P1065...05784/P1698

Indicated on display	Possible cause of fault	Possible effects	Fault remedy
04197/P1065 Fuel pressure control Control difference	<ul style="list-style-type: none"> ◆ Wiring short to positive ◆ Fuel pressure sender -G247- defective ◆ Fuel pressure regulating valve -N276- defective 	<ul style="list-style-type: none"> ◆ Exhaust gas warning lamp -K83- lights up ◆ Increase exhaust emissions with engine cold 	<ul style="list-style-type: none"> – -G247- Check. ⇒ page 235 Check return flow rate from fuel pressure regulating valve -N276- ⇒ page 220 – -N276- Check. ⇒ page 232
04663/P1237 Injector, cylinder 1 -N30- Open circuit	<ul style="list-style-type: none"> ◆ Wiring open or short circuit ◆ -N30- defective 	<ul style="list-style-type: none"> ◆ Glow period warning lamp -K29- lights up ◆ Exhaust gas warning lamp -K83- lights up ◆ Engine idling rough or engine stalls ◆ Reduced performance ◆ Increased exhaust emissions 	<ul style="list-style-type: none"> – -N30- Check. ⇒ page 241
04664/P1238 Injector, cylinder 2 -N31- Open circuit	<ul style="list-style-type: none"> ◆ Wiring open or short circuit ◆ -N31- defective 	<ul style="list-style-type: none"> ◆ Glow period warning lamp -K29- lights up ◆ Exhaust gas warning lamp -K83- lights up ◆ Engine idling rough or engine stalls ◆ Reduced performance ◆ Increased exhaust emissions 	<ul style="list-style-type: none"> – -N31- Check. ⇒ page 241
04665/P1239 Injector, cylinder 3 -N32-			



Indicated on display	Possible cause of fault	Possible effects	Fault remedy
Open circuit	<ul style="list-style-type: none"> ◆ Wiring open or short circuit ◆ -N30- defective 	<ul style="list-style-type: none"> ◆ Glow period warning lamp -K29- lights up ◆ Exhaust gas warning lamp -K83- lights up ◆ Engine idling rough or engine stalls ◆ Reduced performance ◆ Increased exhaust emissions 	<ul style="list-style-type: none"> – -N32- Check. ⇒ page 241
04672/P1240 Injector, cylinder 4 -N33-			
Open circuit	<ul style="list-style-type: none"> ◆ Wiring open or short circuit ◆ -N33- defective 	<ul style="list-style-type: none"> ◆ Glow period warning lamp -K29- lights up ◆ Exhaust gas warning lamp -K83- lights up ◆ Engine idling rough or engine stalls ◆ Reduced performance ◆ Increased exhaust emissions 	<ul style="list-style-type: none"> – -N33- Check. ⇒ page 241
04999/P1387 Control unit defective	<ul style="list-style-type: none"> ◆ Engine control unit -J623- defective 	<ul style="list-style-type: none"> ◆ Exhaust gas warning lamp -K83- lights up ◆ Reduced performance ◆ Increased exhaust emissions ◆ Various running problems 	<ul style="list-style-type: none"> – -J623- Renew. ⇒ page 259
05000/P1388 Control unit defective	<ul style="list-style-type: none"> ◆ Engine control unit -J623- defective 	<ul style="list-style-type: none"> ◆ Glow period warning lamp -K29- lights up ◆ Exhaust gas warning lamp -K83- lights up ◆ Various running problems 	<ul style="list-style-type: none"> – -J623- Renew. ⇒ page 259
05120/P1400 Exhaust gas recirculation valve			
Electrical fault in current circuit	<ul style="list-style-type: none"> ◆ Wiring open or short circuit ◆ -N18- defective 	<ul style="list-style-type: none"> ◆ Exhaust gas warning lamp -K83- lights up ◆ No exhaust gas recirculation ◆ Reduced performance ◆ Increased exhaust emissions ◆ No regeneration of particulate filter 	<ul style="list-style-type: none"> – Check -N18- ⇒ page 47, Final control diagnosis



Indicated on display	Possible cause of fault	Possible effects	Fault remedy
05121/P1401 Exhaust gas recirculation valve Short to earth	<ul style="list-style-type: none"> ◆ Wire open circuit or wire has short to earth ◆ -N18- defective 	<ul style="list-style-type: none"> ◆ Exhaust gas warning lamp -K83- lights up ◆ No exhaust gas recirculation ◆ Reduced performance ◆ Increased exhaust emissions ◆ No regeneration of particulate filter 	<ul style="list-style-type: none"> – Check -N18- ⇒ page 47, Final control diagnosis
05122/P1402 Exhaust gas recirculation valve Short to positive	<ul style="list-style-type: none"> ◆ Wiring open circuit or wiring short to positive ◆ -N18- defective 	<ul style="list-style-type: none"> ◆ Exhaust gas warning lamp -K83- lights up ◆ No exhaust gas recirculation ◆ Reduced performance ◆ Increased exhaust emissions ◆ No regeneration of particulate filter 	<ul style="list-style-type: none"> – Check -N18- ⇒ page 47, Final control diagnosis
05184/P1440 Exhaust gas recirculation valve Open circuit	<ul style="list-style-type: none"> ◆ Wiring open circuit ◆ -N18- defective 	<ul style="list-style-type: none"> ◆ Exhaust gas warning lamp -K83- lights up ◆ No exhaust gas recirculation ◆ Reduced performance ◆ Increased exhaust emissions ◆ No regeneration of particulate filter 	<ul style="list-style-type: none"> – Check -N18- ⇒ page 47, Final control diagnosis
05214/P145E Air mass meter flow rate in regeneration mode Too low	<ul style="list-style-type: none"> ◆ Exhaust gas recirculation system leaking ◆ -N18- defective 	<ul style="list-style-type: none"> ◆ Glow period warning lamp -K29- lights up ◆ Exhaust gas warning lamp -K83- lights up 	<ul style="list-style-type: none"> – Check exhaust gas recirculation system for leaks ⇒ page 267 – Check -N18- ⇒ page 47, Final control diagnosis



Indicated on display	Possible cause of fault	Possible effects	Fault remedy
<p>05215/P145F Air mass meter flow rate in regeneration mode Too high</p>	<ul style="list-style-type: none"> ◆ Exhaust gas recirculation system leaking ◆ -N18- defective 	<ul style="list-style-type: none"> ◆ Glow period warning lamp -K29- lights up ◆ Exhaust gas warning lamp -K83- lights up 	<ul style="list-style-type: none"> - Check exhaust gas recirculation system for leaks ⇒ page 267 - Check -N18- ⇒ page 47, Final control diagnosis
<p>05379/P1503 Load signal from alternator terminal DF Implausible signal</p>	<ul style="list-style-type: none"> ◆ Wiring open or short circuit ◆ Alternator -C- defective ◆ Voltage regulator -C1- defective 	<ul style="list-style-type: none"> ◆ Various running problems 	<ul style="list-style-type: none"> - Check alternator -C- and voltage regulator -C1- ⇒ page 294.
<p>05455/P154F Charge air pressure control Malfunction</p>	<ul style="list-style-type: none"> ◆ Charge pressure control defective ◆ Turbocharger defective ◆ Charge air pressure routing leaking 	<ul style="list-style-type: none"> ◆ Reduced performance ◆ Charge pressure too low 	<ul style="list-style-type: none"> - Checking charge air system for leaks ⇒ page 190 - Checking charge pressure control ⇒ page 192.
<p>05488/P1570 Engine control unit blocked</p>	<ul style="list-style-type: none"> ◆ Ignition key defective. ◆ Gateway control unit defective 	<ul style="list-style-type: none"> ◆ Glow period warning lamp -K29- lights up ◆ Engine will not start ◆ Engine stops 	<ul style="list-style-type: none"> - Renew Gateway control unit
<p>05522/P1592 Signal for altitude sender/charge air pressure sensor Implausible ratio</p>	<ul style="list-style-type: none"> ◆ Charge air pressure sender -G31- defective ◆ Altitude sender -F96- in engine control unit -J623- defective 	<ul style="list-style-type: none"> ◆ Glow period warning lamp -K29- lights up ◆ Exhaust gas warning lamp -K83- lights up ◆ No charge air pressure control ◆ No exhaust gas recirculation ◆ Reduced performance ◆ Increased exhaust emissions ◆ No regeneration of particulate filter 	<ul style="list-style-type: none"> - -G31- Check. ⇒ page 199 - Renew -J623- if necessary ⇒ page 259



Indicated on display	Possible cause of fault	Possible effects	Fault remedy
05635/P1603 Control unit defective	◆ Engine control unit -J623-, internal defect	◆ Engine stops	– -J623- Renew. ⇒ page 259
05636/P1603 Control unit defective	◆ Engine control unit -J623-, internal defect	◆ Glow period warning lamp -K29- lights up ◆ Exhaust gas warning lamp -K83- lights up ◆ Various running problems ◆ Engine stops ◆ No regeneration of particulate filter	– -J623- Renew. ⇒ page 259
05642/P160A Control unit defective	◆ Engine control unit -J623-, internal defect	◆ Glow period warning lamp -K29- lights up ◆ Exhaust gas warning lamp -K83- lights up ◆ Various running problems ◆ Engine stops	– -J623- Renew. ⇒ page 259
05648/P1610 Control unit defective	◆ Engine control unit -J623-, internal defect	◆ Glow period warning lamp -K29- lights up ◆ Various running problems ◆ Engine stops	– -J623- Renew. ⇒ page 259
05650/P1612 Engine control unit Incorrectly coded	◆ Invalid control unit coding for engine control unit -J623-	◆ Glow period warning lamp -K29- lights up ◆ Various running problems ◆ Engine stops	– Recode -J623- (according to manufacturer instructions)
05654/P1616 Glow period warning lamp -K29- Short to positive	◆ Wiring short to positive ◆ -K29- defective	---	– Check -K29- ⇒ page 47, Final control diagnosis
05655/P1617 Glow period warning lamp -K29- Open circuit/short to earth	◆ Wire open circuit or wire has short to earth ◆ -K29- defective	---	– Check -K29- ⇒ page 47, Final control diagnosis



Indicated on display	Possible cause of fault	Possible effects	Fault remedy
05694/P163E Control unit defective	<ul style="list-style-type: none"> ◆ Engine control unit -J623-, internal defect 	<ul style="list-style-type: none"> ◆ Glow period warning lamp -K29- lights up ◆ Exhaust gas warning lamp -K83- lights up ◆ Various running problems ◆ Engine stops 	<ul style="list-style-type: none"> – -J623- Renew. ⇒ page 259
05696/P1640 Control unit defective	<ul style="list-style-type: none"> ◆ Engine control unit -J623-, internal defect 	<ul style="list-style-type: none"> ◆ Glow period warning lamp -K29- lights up ◆ Exhaust gas warning lamp -K83- lights up ◆ Various running problems ◆ Engine stops 	<ul style="list-style-type: none"> – -J623- Renew. ⇒ page 259
05703/P1647 Check coding/version of control unit in wiring harness	<ul style="list-style-type: none"> ◆ Invalid control unit coding 	<ul style="list-style-type: none"> ◆ Glow period warning lamp -K29- lights up ◆ Various running problems ◆ Engine stops 	<ul style="list-style-type: none"> – Recode -J623- (according to manufacture instructions)
05719/P1657 Air conditioner input/output Short to positive 05748/P1674 Powertrain data bus Implausible message from instrument cluster 05778/P1692 Self-diagnosis fault indicator lamp -K83	<ul style="list-style-type: none"> ◆ Wire open circuit or wire has short to earth ◆ Air conditioner compressor defective. ◆ Fault in the data lines to instrument cluster 	<ul style="list-style-type: none"> ◆ Air conditioning system not functioning ◆ Instrument cluster not functioning or functions are restricted ◆ Cruise control system not functioning 	<ul style="list-style-type: none"> – Check wiring connections from -J623- to air conditioner compressor ⇒ page 305, Current flow diagram – Check data bus ⇒ page 264 – Check coding of instrument cluster (according to manufacture instructions)



Indicated on display	Possible cause of fault	Possible effects	Fault remedy
Short to earth 05779/P1693 Self-diagnosis fault indicator lamp -K83 Short to positive	<ul style="list-style-type: none"> ◆ Wire open circuit or wire has short to earth ◆ Wiring open circuit or wiring short to positive 	<ul style="list-style-type: none"> ◆ Exhaust gas warning lamp -K83- lights up ◆ Exhaust gas warning lamp -K83- lights up 	<ul style="list-style-type: none"> – Check -K83- ⇒ page 47, Final control diagnosis – Check wiring/connections ⇒ page 305, Current flow diagram – Check -K83- ⇒ page 47, Final control diagnosis – Check wiring/connections ⇒ page 305, Current flow diagram

3.4 Fault code: 08194/P2002...09780/P2634

Indicated on display	Possible cause of fault	Possible effects	Fault remedy
08194/P2002 Particulate filter, bank 1 Malfunction	<ul style="list-style-type: none"> ◆ -G450- defective ◆ Control line between exhaust gas pressure sensor 1 -G450- and particulate filter is blocked ◆ -G70- defective ◆ -G495- defective ◆ -G648- defective 	<ul style="list-style-type: none"> ◆ Exhaust gas warning lamp -K83- lights up 	<ul style="list-style-type: none"> – -G450- Check. ⇒ page 280 – Check control line ⇒ page 266, Assembly overview - particulate filter – Check particulate filter ⇒ page 282 – -G70- Check. ⇒ page 253 – -G495- Check. ⇒ page 275 – -G648-Check. ⇒ page 277
08320/P2080 Exhaust gas temperature sender 1 Implausible signal	<ul style="list-style-type: none"> ◆ Wiring open or short circuit ◆ -G235- defective 	<ul style="list-style-type: none"> ◆ Exhaust gas warning lamp -K83- lights up 	<ul style="list-style-type: none"> – -G235- Check. ⇒ page 204
08448/P2100 Throttle valve module			



Indicated on display	Possible cause of fault	Possible effects	Fault remedy
Open circuit	<ul style="list-style-type: none"> ◆ Wiring open or short circuit ◆ -J388- defective 	<ul style="list-style-type: none"> ◆ Glow period warning lamp -K29- lights up ◆ Exhaust gas warning lamp -K83- lights up ◆ No regeneration of particulate filter 	<ul style="list-style-type: none"> - Check -J338- ⇒ page 47, Final control diagnosis - -J338- Check. ⇒ page 255
08450/P2102 Throttle valve module, control motor activation			
Signal too low	<ul style="list-style-type: none"> ◆ Wiring open or short circuit ◆ -J388- defective 	<ul style="list-style-type: none"> ◆ Glow period warning lamp -K29- lights up ◆ Exhaust gas warning lamp -K83- lights up ◆ No regeneration of particulate filter 	<ul style="list-style-type: none"> - Check -J338- ⇒ page 47, Final control diagnosis - -J338- Check. ⇒ page 255
08451/P2103 Throttle valve module, control motor activation			
Signal too large	<ul style="list-style-type: none"> ◆ Wiring open or short circuit ◆ -J388- defective 	<ul style="list-style-type: none"> ◆ Glow period warning lamp -K29- lights up ◆ Exhaust gas warning lamp -K83- lights up ◆ No regeneration of particulate filter 	<ul style="list-style-type: none"> - Check -J338- ⇒ page 47, Final control diagnosis - -J338- Check. ⇒ page 255
08465/P2111 Throttle valve module			
Stuck open	<ul style="list-style-type: none"> ◆ -J388- soiled ◆ -J388- defective 	<ul style="list-style-type: none"> ◆ Glow period warning lamp -K29- lights up ◆ Exhaust gas warning lamp -K83- lights up ◆ No regeneration of particulate filter 	<ul style="list-style-type: none"> - Check -J338- ⇒ page 47, Final control diagnosis - -J338- Check. ⇒ page 255 - Clean -J338-, re-new if necessary
08466/P2112 Throttle valve module			
Stuck open	<ul style="list-style-type: none"> ◆ -J388- soiled ◆ -J388- defective 	<ul style="list-style-type: none"> ◆ Glow period warning lamp -K29- lights up ◆ Exhaust gas warning lamp -K83- lights up ◆ No regeneration of particulate filter 	<ul style="list-style-type: none"> - Check -J338- ⇒ page 47, Final control diagnosis - -J338- Check. ⇒ page 255 - Clean -J338-, re-new if necessary
08482/P2122 Accelerator position sender			
Signal too low	<ul style="list-style-type: none"> ◆ Wiring open circuit or wiring short to positive ◆ -G79- defective 	<ul style="list-style-type: none"> ◆ Glow period warning lamp -K29- lights up ◆ No regulation of engine revs 	<ul style="list-style-type: none"> - -G79- Check. ⇒ page 180



Indicated on display	Possible cause of fault	Possible effects	Fault remedy
08483/P2123 Accelerator position sender Signal too large	<ul style="list-style-type: none"> ◆ Wire open circuit or wire has short to earth ◆ -G79- defective 	<ul style="list-style-type: none"> ◆ Glow period warning lamp -K29- lights up ◆ No regulation of engine revs 	– -G79- Check. ⇒ page 180
08487/P2127 Accelerator position sender 2 Signal too low	<ul style="list-style-type: none"> ◆ Wiring open circuit or wiring short to positive ◆ -G185- defective 	<ul style="list-style-type: none"> ◆ Glow period warning lamp -K29- lights up ◆ No regulation of engine revs 	– -G79- Check. ⇒ page 180
08488/P2128 Accelerator position sender 2 Signal too large	<ul style="list-style-type: none"> ◆ Wire open circuit or wire has short to earth ◆ -G185- defective 	<ul style="list-style-type: none"> ◆ Glow period warning lamp -K29- lights up ◆ No regulation of engine revs 	– -G79- Check. ⇒ page 180
08504/P2138 Accelerator position sender 1/2 -G79 + G185- Implausible signal	<ul style="list-style-type: none"> ◆ Wiring open or short circuit ◆ -G79/G185- defective 	<ul style="list-style-type: none"> ◆ Glow period warning lamp -K29- lights up ◆ No regulation of engine revs 	– -G79- Check. ⇒ page 180
08518/P2146 Injector(s) supply A Open circuit	<ul style="list-style-type: none"> ◆ Wiring open or short circuit ◆ -N30...N33- defective 	<ul style="list-style-type: none"> ◆ Glow period warning lamp -K29- lights up ◆ Engine stalls 	– -N30...N33- Check. ⇒ page 241
08521/P2149 Injector(s) supply B Open circuit	<ul style="list-style-type: none"> ◆ Wiring open or short circuit ◆ -N30...N33- defective 	<ul style="list-style-type: none"> ◆ Glow period warning lamp -K29- lights up ◆ Engine stalls 	– -N30...N33- Check. ⇒ page 241
08597/P2195 Lambda probe 1, bank 1			



Indicated on display	Possible cause of fault	Possible effects	Fault remedy
Signal too lean 08598/P2196 Lambda probe 1, bank 1	<ul style="list-style-type: none"> ◆ Wiring open circuit ◆ Lambda probe -G39-defective 	<ul style="list-style-type: none"> ◆ Exhaust gas warning lamp -K83- lights up ◆ No exhaust gas control ◆ Increased exhaust emissions ◆ Regeneration of NOx storage catalytic converter 	– -G39- Check. ⇒ page 272
Signal too rich 08759/P2237 Lambda probe 1, bank 1, pump current	<ul style="list-style-type: none"> ◆ Wiring open circuit ◆ Lambda probe -G39-defective 	<ul style="list-style-type: none"> ◆ Exhaust gas warning lamp -K83- lights up ◆ No exhaust gas control ◆ Increased exhaust emissions ◆ Regeneration of NOx storage catalytic converter 	– -G39- Check. ⇒ page 272
Open circuit 08771/P2243 Lambda probe 1, bank 1, reference voltage	<ul style="list-style-type: none"> ◆ Wiring open circuit ◆ Lambda probe -G39-defective 	<ul style="list-style-type: none"> ◆ Exhaust gas warning lamp -K83- lights up ◆ No exhaust gas control ◆ No exhaust gas temperature control ◆ Increased exhaust emissions ◆ Regeneration of NOx storage catalytic converter 	– -G39- Check. ⇒ page 272
Open circuit	<ul style="list-style-type: none"> ◆ Wiring open circuit ◆ Lambda probe -G39-defective 	<ul style="list-style-type: none"> ◆ Exhaust gas warning lamp -K83- lights up ◆ No exhaust gas control ◆ No exhaust gas temperature control ◆ Increased exhaust emissions ◆ Regeneration of NOx storage catalytic converter 	– -G39- Check. ⇒ page 272



Indicated on display	Possible cause of fault	Possible effects	Fault remedy
08785/P2251 Lambda probe 1, bank 1, earth wiring Open circuit	<ul style="list-style-type: none"> ◆ Wiring open circuit ◆ Lambda probe -G39- defective 	<ul style="list-style-type: none"> ◆ Exhaust gas warning lamp -K83- lights up ◆ No exhaust gas control ◆ No exhaust gas temperature control ◆ Increased exhaust emissions ◆ Regeneration of NOx storage catalytic converter 	<ul style="list-style-type: none"> – -G39- Check. ⇒ page 272
08825/P2279 Intake system leak	<ul style="list-style-type: none"> ◆ Leaks between turbocharger and engine (charge air routing) 	<ul style="list-style-type: none"> ◆ Glow period warning lamp -K29- lights up ◆ Exhaust gas warning lamp -K83- lights up ◆ No exhaust gas recirculation ◆ Reduced performance ◆ Charge pressure too low ◆ Particulate filter regeneration blocked 	<ul style="list-style-type: none"> – Checking charge air system for leaks ⇒ page 190 – Checking charge pressure control ⇒ page 192.
08852/P2294 Fuel pressure regulating valve Open circuit	<ul style="list-style-type: none"> ◆ Wiring open circuit ◆ Fuel pressure regulating valve -N276- defective 	<ul style="list-style-type: none"> ◆ Glow period warning lamp -K29- lights up ◆ Exhaust gas warning lamp -K83- lights up ◆ Engine stalls 	<ul style="list-style-type: none"> – -N276- Check. ⇒ page 232
08853/P2295 Fuel pressure regulating valve Short to earth	<ul style="list-style-type: none"> ◆ Wiring short to earth ◆ Fuel pressure regulating valve -N276- defective 	<ul style="list-style-type: none"> ◆ Glow period warning lamp -K29- lights up ◆ Exhaust gas warning lamp -K83- lights up ◆ Engine stalls 	<ul style="list-style-type: none"> – -N276- Check. ⇒ page 232
08854/P2296 Fuel pressure regulating valve Short to positive	<ul style="list-style-type: none"> ◆ Wiring short to positive ◆ Fuel pressure regulating valve -N276- defective 	<ul style="list-style-type: none"> ◆ Glow period warning lamp -K29- lights up ◆ Exhaust gas warning lamp -K83- lights up ◆ Engine stalls 	<ul style="list-style-type: none"> – -N276- Check. ⇒ page 232



Indicated on display	Possible cause of fault	Possible effects	Fault remedy
09258/P242A Exhaust gas temperature sender 3, bank 1 Electrical fault	<ul style="list-style-type: none"> ◆ Wiring open or short circuit ◆ -G495- defective 	<ul style="list-style-type: none"> ◆ Glow period warning lamp -K29- lights up ◆ Exhaust gas warning lamp -K83- lights up ◆ Increased exhaust emissions ◆ Particulate filter regeneration blocked 	<ul style="list-style-type: none"> – -G495- Check. ⇒ page 275
09259/P242B Exhaust gas temperature sender 3, bank 1 Implausible signal	<ul style="list-style-type: none"> ◆ Wiring open or short circuit ◆ -G495- defective 	<ul style="list-style-type: none"> ◆ Exhaust gas warning lamp -K83- lights up 	<ul style="list-style-type: none"> – -G495- Check. ⇒ page 275
09260/P242C Exhaust gas temperature sender 3, bank 1 Short to earth	<ul style="list-style-type: none"> ◆ Wiring short to earth ◆ -G495- defective 	<ul style="list-style-type: none"> ◆ Glow period warning lamp -K29- lights up ◆ Exhaust gas warning lamp -K83- lights up ◆ Particulate filter regeneration blocked 	<ul style="list-style-type: none"> – -G495- Check. ⇒ page 275
09298/P2452 Diesel particulate filter, pressure differential sender Electrical fault	<ul style="list-style-type: none"> ◆ Wiring open or short circuit ◆ -G450- defective 	<ul style="list-style-type: none"> ◆ Exhaust gas warning lamp -K83- lights up ◆ Particulate filter regeneration blocked 	<ul style="list-style-type: none"> – -G450- Check. ⇒ page 280
09299/P2453 Diesel particulate filter, pressure differential sender Implausible signal	<ul style="list-style-type: none"> ◆ Wire open circuit or wire has short to earth ◆ -G450- defective ◆ Control line between -G450- and particulate filter is blocked or interchanged 	<ul style="list-style-type: none"> ◆ Exhaust gas warning lamp -K83- lights up 	<ul style="list-style-type: none"> – -G450- Check. ⇒ page 280 – Check control line ⇒ page 266, Assembly overview - particulate filter – Check particulate filter ⇒ page 282
09300/P2454 Diesel particulate filter, pressure differential sender			



Indicated on display	Possible cause of fault	Possible effects	Fault remedy
Short to earth	<ul style="list-style-type: none"> ◆ Wiring short to earth ◆ -G450- defective 	<ul style="list-style-type: none"> ◆ Exhaust gas warning lamp -K83- lights up ◆ Reduced performance ◆ Increased exhaust emissions ◆ Particulate filter regeneration blocked 	<ul style="list-style-type: none"> - -G450- Check. ⇒ page 280 - Check control line ⇒ page 266, Assembly overview - particulate filter - Check particulate filter ⇒ page 282
09315/P2463 Diesel particulate filter Soot saturation too high	<ul style="list-style-type: none"> ◆ Diesel particulate filter overloaded, e.g., running engine for short periods only 	<ul style="list-style-type: none"> ◆ Glow period warning lamp -K29- lights up ◆ Exhaust gas warning lamp -K83- lights up ◆ Reduced performance ◆ Increased exhaust emissions ◆ No exhaust gas recirculation ◆ Particulate filter regeneration blocked 	<ul style="list-style-type: none"> - Check particulate filter ⇒ page 282
09326/P246E Exhaust gas temperature sender 4, bank 1 Electrical fault	<ul style="list-style-type: none"> ◆ Wiring open or short circuit ◆ -G648- defective 	<ul style="list-style-type: none"> ◆ Glow period warning lamp -K29- lights up ◆ Exhaust gas warning lamp -K83- lights up ◆ Increased exhaust emissions ◆ Particulate filter regeneration blocked 	<ul style="list-style-type: none"> - -G648- Check. ⇒ page 277
09327/P246F Exhaust gas temperature sender 4, bank 1 Implausible signal	<ul style="list-style-type: none"> ◆ Wiring open or short circuit ◆ -G648- defective 	<ul style="list-style-type: none"> ◆ Exhaust gas warning lamp -K83- lights up 	<ul style="list-style-type: none"> - -G648- Check. ⇒ page 277
09328/P2470 Exhaust gas temperature sender 4, bank 1 Short to earth	<ul style="list-style-type: none"> ◆ Wiring short to earth ◆ -G648- defective 	<ul style="list-style-type: none"> ◆ Glow period warning lamp -K29- lights up ◆ Exhaust gas warning lamp -K83- lights up ◆ Particulate filter regeneration blocked 	<ul style="list-style-type: none"> - -G648- Check. ⇒ page 277



Indicated on display	Possible cause of fault	Possible effects	Fault remedy
09571/P2563 Position sender for charge pressure positioner Implausible signal	<ul style="list-style-type: none"> ◆ Wiring open or short circuit ◆ -G581- defective 	<ul style="list-style-type: none"> ◆ Glow period warning lamp -K29- lights up ◆ Exhaust gas warning lamp -K83- lights up 	<ul style="list-style-type: none"> – -G581- Check. ⇒ page 202
09572/P2564 Position sender for charge pressure positioner Signal too low	<ul style="list-style-type: none"> ◆ Wiring open or short circuit ◆ -G581- defective 	<ul style="list-style-type: none"> ◆ Glow period warning lamp -K29- lights up ◆ Exhaust gas warning lamp -K83- lights up ◆ Reduced performance ◆ Particulate filter regeneration blocked 	<ul style="list-style-type: none"> – -G581- Check. ⇒ page 202
09573/P2565 Position sender for charge pressure positioner Signal too high	<ul style="list-style-type: none"> ◆ Wiring open or short circuit ◆ -G581- defective 	<ul style="list-style-type: none"> ◆ Glow period warning lamp -K29- lights up ◆ Exhaust gas warning lamp -K83- lights up ◆ Reduced performance ◆ Particulate filter regeneration blocked 	<ul style="list-style-type: none"> – -G581- Check. ⇒ page 202
09742/P0260E Activation of diesel particulate filter warning lamp	<ul style="list-style-type: none"> ◆ Wiring open or short circuit ◆ Warning lamp defective 		<ul style="list-style-type: none"> – Check warning lamp ⇒ page 47, Final control diagnosis – Check wiring/connections ⇒ page 305, Current flow diagram
09744/P2610 Control unit defective	<ul style="list-style-type: none"> ◆ Engine control unit -J623-, internal defect 	<ul style="list-style-type: none"> ◆ Exhaust gas warning lamp -K83- lights up 	<ul style="list-style-type: none"> – -J623- Renew. ⇒ page 259
09756/P261C Coolant circulation pump 2			



Indicated on display	Possible cause of fault	Possible effects	Fault remedy
Short to earth	<ul style="list-style-type: none"> ◆ Wiring short to earth ◆ -V178- defective 	<ul style="list-style-type: none"> ◆ Exhaust gas warning lamp -K83- lights up ◆ Increased exhaust emissions ◆ No exhaust gas recirculation ◆ No exhaust gas recirculation cooling 	<ul style="list-style-type: none"> – Check -V178- ⇒ page 305, Current flow diagram
09756/P261D Coolant circulation pump 2			
Short to positive	<ul style="list-style-type: none"> ◆ Wiring short to positive ◆ -V178- defective 	<ul style="list-style-type: none"> ◆ Exhaust gas warning lamp -K83- lights up ◆ Increased exhaust emissions ◆ No exhaust gas recirculation ◆ No exhaust gas recirculation cooling 	<ul style="list-style-type: none"> – Check -V178- ⇒ page 305, Current flow diagram
09778/P2632 Electric fuel pump 2 relay -J49-			
Open circuit	<ul style="list-style-type: none"> ◆ Wiring open circuit ◆ -J49- defective 	<ul style="list-style-type: none"> ◆ Glow period warning lamp -K29- lights up ◆ Exhaust gas warning lamp -K83- lights up ◆ Supplementary fuel pump -V393- stops working ◆ Low-pressure fuel pressure too low 	<ul style="list-style-type: none"> – Check -J49- ⇒ page 47, Final control diagnosis – Check wiring to -J49- ⇒ page 305, Current flow diagram – Renew -J623- if necessary ⇒ page 259
09779/P2633 Electric fuel pump 2 relay -J49-			



Indicated on display	Possible cause of fault	Possible effects	Fault remedy
Short to earth 09780/P2634 Electric fuel pump 2 relay -J49-	<ul style="list-style-type: none"> ◆ Wiring short to earth ◆ -J49- defective 	<ul style="list-style-type: none"> ◆ Glow period warning lamp -K29- lights up ◆ Exhaust gas warning lamp -K83- lights up ◆ Supplementary fuel pump -V393- stops working ◆ Low-pressure fuel pressure too low 	<ul style="list-style-type: none"> – Check -J49- ⇒ page 47, Final control diagnosis – Check wiring to -J49- ⇒ page 305, Current flow diagram – Renew -J623- if necessary ⇒ page 259
Short to positive	<ul style="list-style-type: none"> ◆ Wiring short to positive ◆ -J49- defective 	<ul style="list-style-type: none"> ◆ Glow period warning lamp -K29- lights up ◆ Exhaust gas warning lamp -K83- lights up ◆ Supplementary fuel pump -V393- stops working ◆ Low-pressure fuel pressure too low 	<ul style="list-style-type: none"> – Check -J49- ⇒ page 47, Final control diagnosis – Check wiring to -J49- ⇒ page 305, Current flow diagram – Renew -J623- if necessary ⇒ page 259

3.5 Fault code: 12259/P3007...13093/P3325

Indicated on display	Possible cause of fault	Possible effects	Fault remedy
12259/P3007 Camshaft position sensor -G40- No signal	<ul style="list-style-type: none"> ◆ Wiring open or short circuit ◆ Hall sender -G40- defective or loose ◆ Metal particles on hub or Hall sender -G40- ◆ Gap Hall sender -G40-/hub too large ◆ Hub with sender wheel on camshaft is twisted or loose 	<ul style="list-style-type: none"> ◆ Increased exhaust emissions ◆ Reduced output at full load/throttle ◆ High fuel consumption ◆ Engine starts reluctantly or not at all when cold 	<ul style="list-style-type: none"> – -G40- Check. ⇒ page 245 – Check position of camshaft and sender wheel ⇒ page 117, Removing, installing and tensioning toothed belt.
12406/P3076 Engine control unit			



Indicated on display	Possible cause of fault	Possible effects	Fault remedy
Fault with coding	<ul style="list-style-type: none"> ◆ Invalid control unit coding for engine control unit -J623- 	<ul style="list-style-type: none"> ◆ Glow period warning lamp -K29- lights up ◆ Various running problems ◆ Engine stops 	<ul style="list-style-type: none"> – Recode -J623- (according to manufacture instructions) – Renew -J623- if necessary ⇒ page 259
12703/P0319F Working speed control warning lamp Electrical fault	<ul style="list-style-type: none"> ◆ Wiring open or short circuit ◆ Warning lamp defective 		<ul style="list-style-type: none"> – Check wiring/connections ⇒ page 305, Current flow diagram
12704/P31A0 Working speed control switch Electrical fault	<ul style="list-style-type: none"> ◆ Wiring open or short circuit ◆ Switch defective 		<ul style="list-style-type: none"> – Check wiring/connections ⇒ page 305, Current flow diagram
12867/P3243 Activation of throttle valve module Electrical fault	<ul style="list-style-type: none"> ◆ Wiring open or short circuit ◆ -J388- defective 	<ul style="list-style-type: none"> ◆ Glow period warning lamp -K29- lights up ◆ Exhaust gas warning lamp -K83- lights up ◆ No regeneration of particulate filter 	<ul style="list-style-type: none"> – Check -J338- ⇒ page 47, Final control diagnosis – -J338- Check. ⇒ page 255
13093/P3325 Terminal 15 voltage supply relay Implausible	<ul style="list-style-type: none"> ◆ No current supply when ignition is on (terminal 15) 	<ul style="list-style-type: none"> ◆ Engine will not start 	<ul style="list-style-type: none"> – Check voltage supply for engine control unit -J623- ⇒ page 257



3.6 Fault code: 49153/U0001...54282/U140A

Indicated on display	Possible cause of fault	Possible effects	Fault remedy
49153/U0001 Powertrain data bus defective	<ul style="list-style-type: none"> ◆ Fault in data wiring ◆ No communication 	<ul style="list-style-type: none"> ◆ Glow period warning lamp -K29- lights up ◆ Exhaust gas warning lamp -K83- lights up ◆ Engine will not start 	<ul style="list-style-type: none"> – Check data bus ⇒ page 264
53285/U1025 Read fault memory of air conditioner control unit	<ul style="list-style-type: none"> ◆ Refrigerant pressure not OK. 	<ul style="list-style-type: none"> ◆ Air conditioning not functioning or functions are restricted ◆ Coolant fan runs at full speed 	<ul style="list-style-type: none"> – Check air conditioner
54282/U140A Terminal 30 Open circuit	<ul style="list-style-type: none"> ◆ Voltage supply too low ◆ Defective terminal 30 voltage supply relay -J317- 	<ul style="list-style-type: none"> ◆ Engine will not start ◆ Various running problems including engine will not start 	<ul style="list-style-type: none"> – Check voltage supply for engine control unit -J623- ⇒ page 257

4 Final control diagnosis

Perform final control diagnosis ⇒ page 47

◆

4.1 Performing final control diagnosis

The final control diagnosis actuates the following components in the stated sequence:

- 1 - Exhaust gas recirculation valve -N18-
- 2 - Charge pressure control solenoid valve -N75-
- 3 - Alternator switch-off (if fitted)
- 4 - Throttle valve module -J338-
- 5 - Warning lamp for preliminary heating time -K29-
- 6 - Exhaust gas warning lamp -K83-
- 7 - Warning lamp for diesel particle filter -K231-
- 8 - Radiator fan control unit -J293-, radiator fan activation 1
- 9 - Automatic glow period control unit -J179-
- 10- Electric fuel pump relay -J49-
- 11- Supplementary fuel pump -V393-



Note

- ◆ Activation of individual control elements is limited to 120 s but can be stopped at any time by pressing the key.
- ◆ The ignition must be switched off before repeating the final control diagnosis.

Special tools and workshop equipment required



- ♦ Vehicle diagnosis, testing and information system
-VAS 5051- with diagnosis cable -VAS 5051/6A-

 **Note**

Other diagnosis testers can be used instead of the vehicle diagnosis, testing and information system.

Test prerequisites

- Fuses must be OK.
- The battery voltage must be at least 11.5 V.
- All electrical consumers must be switched off.
- Earth connection OK.
- Coolant temperature must be at least 80 °C, ⇒ display group 1, display zone 4.

Procedure

- Connect vehicle diagnosis, testing and information system -VAS 5051- and select diagnosis function "005-Final control diagnosis". the engine must be idling when doing so. (Connect vehicle diagnosis, testing and information system and select engine control unit ⇒ [page 3](#)).

Actuating exhaust gas recirculation valve -N18-

 **Note**

The first control element is actuated immediately after selecting diagnosis function "03-Final control diagnosis", in this case the exhaust gas recirculation valve -N18-.

The exhaust gas recirculation valve -N18- is actuated.

The displays in display zones 3 and 4 must fluctuate within following control range:

- Specification in display zone 3: 180...470 mg/H
- Specification in display zone 4: 70...100 %

 **Note**

The activation of the valve can be checked by touch.

If the valve is not activated:

- Proceed with final control diagnosis until completed.
- Check exhaust gas recirculation ⇒ [page 269](#).

Actuating charge pressure control solenoid valve -N75-

- Press  key.

The charge pressure control solenoid valve -N75- is actuated.

The displays in display zones 2, 3 and 4 must fluctuate within following control range:

Display zone 2: off:

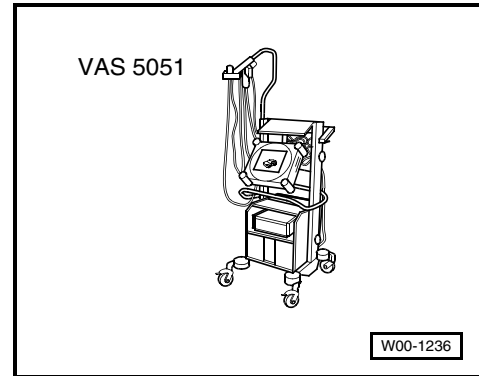



- Specification in display zone 3: 900...1150 mbar
- Specification in display zone 4: 90...5 %

Display zone 2: on:

- Specification in display zone 3: 100 mbar greater than for display off
- Specification in display zone 4: at least 95 %



Note

- ◆ *The activation of the valve can be checked by touch.*
- ◆ *During the activation, the turbocharger charge pressure control actuator rods must move back and forth.*

If the valve is not activated:

- Proceed with final control diagnosis until completed.
- Check charge pressure control ⇒ [page 192](#).

Actuating alternator switch-off (if fitted)

- Press key.

The alternator is actuated.

- The alternator warning lamp must flash.

The display in display zone 4 must fluctuate within the following control range:

Alternator warning lamp off:

- Specification in display zone 4: Battery voltage V

Alternator warning lamp on:

- Specification in display zone 4: Less than for display off

If the alternator is not activated:

- Proceed with final control diagnosis until completed.
- Check alternator referring to current flow diagram ⇒ [page 305](#), Current flow diagram.

Actuating throttle valve module -J338-

- Press key.

The throttle valve module -J338- is actuated.

- The engine must stop when actuating the throttle valve module

If the engine does not stop:

- Proceed with final control diagnosis until completed.
- Switch off ignition.
- Check throttle valve module ⇒ [page 255](#).

Actuating glow period warning lamp -K29-



- Press  key.

The glow period warning lamp -K29- is actuated.

- The warning lamp must flash.

Warning lamp does not flash:

- Check glow period warning lamp -K29- referring to current flow diagram ⇒ [page 305](#), Current flow diagram.

Actuating exhaust emissions warning lamp -K83-

- Press  key.

The exhaust emissions warning lamp -K83- is actuated.

- The exhaust emissions warning lamp must flash.

If exhaust emissions warning lamp does not flash:

- Check exhaust emissions warning lamp -K83- referring to current flow diagram ⇒ [page 305](#), Current flow diagram.

Actuating diesel particulate filter warning lamp -K231- (if fitted)

- Press  key.

The diesel particulate filter warning lamp -K231- is actuated.

- The warning lamp must flash.

Warning lamp does not flash:

- Check diesel particulate filter warning lamp -K231- referring to current flow diagram ⇒ [page 305](#), Current flow diagram.

Actuating radiator fan actuation 1 (if fitted)



DANGER!

Danger of injury from rotating components! Ensure no object, component or wiring blocks the radiator fan.

- Press  key.

The radiator fan will be actuated.

- The radiator fan must act as shown in display zone 2 (on/off).

If radiator fan does not run:

- Check radiator fan actuation 1 referring to current flow diagram ⇒ [page 305](#), Current flow diagram.

Actuating automatic glow period control unit -J179-

- Press  key.

The automatic glow period control unit -J179- is actuated.

- The control unit must click.



 **Note**

The clicking of the control unit is difficult to hear and is therefore best checked by touch.

If the control unit does not click:

- Check wiring for automatic glow period control unit -J179-
⇒ [page 305](#), Current flow diagram.

Actuating electric fuel pump relay -J49-

- Press  key.

The fuel pump -V393- is actuated alternately.

 **Note**

The actuation of the fuel pump -V393- is audible and perceptible.

If the actuation of the supplementary fuel pump -V393- was not audible or perceptible.

- Terminate diagnosis function.
- Check actuation of fuel pump relay -V393- and electric fuel pump 2 relay -J49- ⇒ [page 305](#), Current flow diagram.

Actuating fuel pump

- Press  key.

The fuel pump -V393- is actuated.

 **Note**

The actuation of the fuel pump -V393- is audible and perceptible.

If the actuation of the fuel pump -V393- was not audible or perceptible.

- Terminate diagnosis function.
- Switch off ignition.

Final control diagnosis is completed.

- Check actuation of fuel pump relay -V393- and electric fuel pump 2 relay -J49- ⇒ [page 305](#), Current flow diagram.

5 Data blocks

Observe safety precautions ⇒ [page 52](#).

Reading data block ⇒ [page 52](#).

Evaluating data blocks

- ◆ At idling speed ⇒ [page 53](#).
- ◆ At full load/throttle ⇒ [page 65](#).



5.1 Safety precautions



WARNING!

Due to the cramped conditions, note the following when carrying out repairs:

- ◆ *Route all the various lines (e.g. for fuel, hydraulics, activated charcoal filter system, coolant, refrigerant, brake fluid and vacuum) and electrical wiring in their original positions.*
- ◆ *Ensure that there is sufficient clearance to all moving or hot components.*

To prevent injuries to persons and/or damage to the injection and glow plug system, the following must be noted:

- ◆ Always switch off the ignition before connecting or disconnecting injection and glow plug system wiring or tester cables.
- ◆ If the engine is to be turned at starter speed without starting, e.g. to check compressions, pull off connector -A- from injectors.
- ◆ Disconnecting and connecting the battery must only be done with the ignition switched off, otherwise the engine control unit could be damaged.

Observe following if test and measuring instruments are required during a road test:

- ◆ Test and measuring instruments must be secured and operated by a second person.

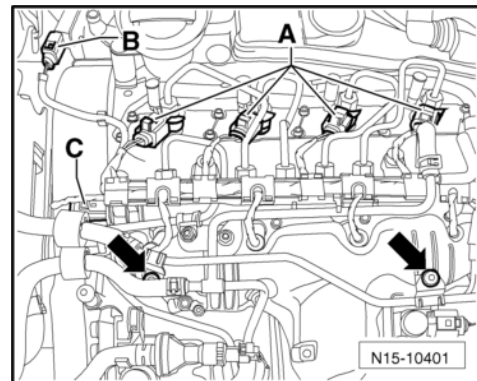

5.2 Reading data block



Note

The data values in diagnosis function "011-Read data block" are described in the descriptions of the individual component tests. This table serves only as an overview.

Special tools and workshop equipment required

- ◆ Vehicle diagnosis, testing and information system -VAS 5051- with diagnosis cable -VAS 5051/6A-



Note

Other diagnosis testers can be used instead of the vehicle diagnosis, testing and information system.

Test prerequisites

- Fuses must be OK.
- The battery voltage must be at least 11.5 V.
- Earth connection OK.
- All electrical consumers must be switched off.

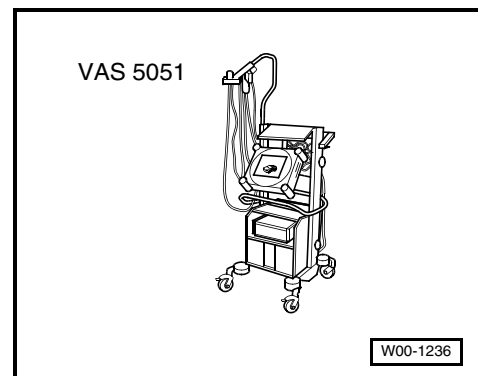



- No faults must be stored in fault memory ⇒ [page 7](#), Reading fault memory.
- Coolant temperature must be at least 80 °C, ⇒ display group 1, display zone 4.

Test procedure

- Connect vehicle diagnosis, testing and information system -VAS 5051- and select diagnosis function “011-Read data block”. the engine must be idling when doing so. (Connect vehicle diagnosis, testing and information system and select engine control unit ⇒ [page 3](#)).

Note

The “display group 1” is an example to illustrate the sequence.

- Select “Display group 1”.

Indicated on display: (1...4 = display zones)

Display group 1			
1	2	3	4

Note

On the display of the vehicle diagnosis, testing and information system -VAS 5051- the display zones are displayed below one another and, next to one another on other diagnosis testers.

- To change to another display group proceed as follows:

Display group	Button
Higher	Press key
Lower	Press key
Skip	Press key

If the specified values are obtained in all the display zones:

- Terminate diagnosis function.
- Switch off ignition.

5.3 Evaluating data blocks at idling speed

Always follow safety precautions ⇒ [page 52](#).

Reading data block ⇒ [page 52](#).

Display group:

- ◆ 1 - Quantity injected ⇒ [page 54](#),
- ◆ 2 - Idling speed ⇒ [page 54](#),
- ◆ 3 - Exhaust gas recirculation ⇒ [page 55](#),
- ◆ 4 - Actuation of injectors -N30...N33- ⇒ [page 56](#),
- ◆ 7 - Temperatures ⇒ [page 56](#),
- ◆ 10 - Air quantities ⇒ [page 57](#),
- ◆ 11 - Charge pressure control ⇒ [page 58](#),
- ◆ 12 - Glow status ⇒ [page 58](#),



- ◆ 13 - Smooth running regulation ⇒ [page 59](#),
- ◆ 20 - Rail quantity 3 ⇒ [page 60](#),
- ◆ 30 - Pedal value sender ⇒ [page 61](#),
- ◆ 34 - Charge air pressure sender ⇒ [page 61](#),
- ◆ 99 - Exhaust gas temperature sender ⇒ [page 62](#),
- ◆ 100 - Particulate filter, exhaust gas temperature, pressure differentials ⇒ [page 63](#),
- ◆ 106 - Particulate filter regeneration 6 ⇒ [page 64](#),
- ◆ 108 - Particulate filter regeneration. 8 ⇒ [page 64](#),

5.3.1 Display group 1 - Quantity injected

Test prerequisites

- Engine running at idling speed.
- Engine warm, coolant temperature not below 80 °C.
- Intake air temperature < 40 °C.

Display zone	Operating condition or component	Specification	Evaluation
1	Engine speed	760...940 rpm	---
2	Average quantity injected	3.0...9.0 mg/H	⇒ page 54
3	High-pressure fuel system (actual)	170.0...350.0 bar	---
4	Coolant temperature	80.0...110.0 °C	---

Evaluation: Display group 1, display zone 2 - quantity injected

Display shows	Possible cause of fault	Fault remedy
Less than specification	◆ Injector (cylinder 1...4) -N30...N33- defective	- -N30...N33- Check. ⇒ page 241
Higher than specification	◆ Engine too cold	- Run engine at increased speed to warm up, and repeat test
	◆ Shortage of fuel ◆ Air in fuel system	- Check fuel supply ⇒ page 172 , Removing and installing parts of fuel supply system - Bleeding fuel system ⇒ page 226
	◆ Injector (cylinder 1...4) -N30...N33- defective	- -N30...N33- Check. ⇒ page 241

5.3.2 Display group 2 - Idling speed

Test prerequisites



- Engine running at idling speed.
- Engine warm, coolant temperature not below 80 °C.
- Intake air temperature < 40 °C.

Display zone	Operating condition or component	Specification	Evaluation
1	Engine speed	760...940 rpm	---
2	Accelerator position ◆ When accelerator position sender -G79- is installed	0,0 %	⇒ page 55
3	Accelerator switch position	---	---
4	Coolant temperature	80.0...110.0 °C	---

Evaluation: Display group 2, display zone 2 - accelerator position

Display shows	Possible cause of fault	Fault remedy
1.0...100.0 %	◆ accelerator position sender -G79- defective ◆ Open circuit to -G79-	- -G79- Check. ⇒ page 180

5.3.3 Display group 3 - Exhaust gas recirculation

Test prerequisites

- Engine running at idling speed.
- Engine warm, coolant temperature not below 80 °C.
- Intake air temperature < 40 °C.

Display zone	Operating condition or component	Specification	Evaluation
1	Engine speed	760...940 rpm	---
2	Intaken air mass (specified):	280...460 mg/stroke	---
3	Intaken air mass (actual):	280...460 mg/h ¹⁾	⇒ page 55
4	Duty cycle of exhaust gas recirculation valve	70...100 %	---

¹⁾ The specification valid for switched-off exhaust gas recirculation system. (Duty cycle of exhaust gas recirculation valve in display zone 4 at 100 %).

Evaluation: Display group 3, display zone 3 - intaken air mass (actual)



Display shows	Possible cause of fault	Fault remedy
Less than specification	◆ Excessive exhaust gas recirculation	– Check exhaust gas recirculation system ⇒ page 269
	◆ Unmetered air	– Check intake system for leaks
Higher than specification	◆ Engine too cold	– Run engine at increased speed to warm up, and repeat test
	◆ Insufficient exhaust gas recirculation	– Engine running for a long time at idling speed, give burst on throttle
	◆ Air mass meter -G70- defective	– -G70- Check. ⇒ page 253

5.3.4 Display group 4 - Actuation of injectors -N30...N33-

Test prerequisites

- Engine running at idling speed.
- Engine warm, coolant temperature not below 80 °C.
- Intake air temperature < 40 °C.

Display zone	Operating condition or component	Specification	Evaluation
1	Engine speed	760...940 rpm	---
2	Main injection, commencement of actuation	-5...5 °CrS	⇒ page 56
3	Main injection, duration of actuation	350...700 ms	---
4	High-pressure fuel system (actual)	170...350 bar	---

Evaluation: Display group 4, display zone 2 - Main injection, commencement of actuation

Display shows	Possible cause of fault	Fault remedy
Higher than specification	◆ Engine too cold	– Run engine at increased speed to warm up, and repeat test

5.3.5 Display group 7 - Temperatures

Test prerequisites

- Ignition switched on.
- Engine not running and cold.



Display zone	Operating condition or component	Specification	Evaluation
1	Fuel temperature	Approx. ambient temperature ¹⁾	⇒ page 57
2	Engine oil temperature	---	---
3	Intake air temperature	Approx. ambient temperature ¹⁾	⇒ page 57
4	Coolant temperature	Approx. ambient temperature ¹⁾	⇒ page 57

¹⁾ Details of temperature specifications are not possible. When the engine is cold the fuel, intake air and coolant temperatures must equate approximately to ambient temperature. If one of the temperature readings is noticeably different, test the relevant sender.

Evaluation: Display group 7, display zone 1 - fuel temperature

Display shows	Possible cause of fault	Fault remedy
Large deviation from ambient temperature	◆ Short circuit or defective fuel temperature sender -G81-	- -G81- Check. ⇒ page 251

Evaluation: Display group 7, display zone 3 - intake air temperature

Display shows	Possible cause of fault	Fault remedy
Large deviation from ambient temperature	◆ Short circuit or defective intake air temperature sender -G42-	- -G42- Check. ⇒ page 246

Evaluation: Display group 7, display zone 4 - coolant temperature

Display shows	Possible cause of fault	Fault remedy
Large deviation from ambient temperature	◆ Short circuit or defective coolant temperature sender -G62-	- -G62- Check. ⇒ page 249

5.3.6 Display group 10 - Air quantities

Test prerequisites

- Engine running at idling speed.
- Engine warm, coolant temperature not below 80 °C.
- Intake air temperature < 40 °C.



Display zone	Operating condition or component	Specification	Evaluation
1	Intaken air mass (actual)	xxx mg/H ¹⁾	---
2	Atmospheric pressure (ambient pressure)	900...1100 mbar	---
3	Charge pressure (actual)	xxx mbar ¹⁾	---
4	Accelerator position ◆ When accelerator position sender -G79- is installed	0,0 %	⇒ page 58

¹⁾ The figures display at "idling speed" are irrelevant.

Evaluation: Display group 10, display zone 4 - accelerator position

Display shows	Possible cause of fault	Fault remedy
1.0...100.0 %	◆ accelerator position sender -G79- defective ◆ Open circuit to -G79-	- -G79- Check. ⇒ page 180

5.3.7 Display group 11 - Charge pressure control

Test prerequisites

- Engine running at idling speed.
- Engine warm, coolant temperature not below 80 °C.
- Intake air temperature < 40 °C.

Display zone	Operating condition or component	Specification	Evaluation
1	Engine speed	760...940 rpm	---
2	Charge pressure (specified)	xxx mbar ¹⁾	---
3	Charge pressure (actual)	xxx mbar ¹⁾	---
4	Duty cycle of charge pressure control solenoid valve	xxx % ¹⁾	---

¹⁾ The figures display at "idling speed" are irrelevant.

5.3.8 Display group 12 - Glow status

Test prerequisites

- Engine running at idling speed.
- Engine warm, coolant temperature not below 80 °C.
- Intake air temperature < 40 °C.



Display zone	Operating condition or component	Specification	Evaluation
1	Glow plug system status	1111 1111	⇒ page 59
2	Glow period (in seconds)	xx.x s	---
3	Voltage supply for automatic glow period control unit	Approx. battery voltage	---
4	Coolant temperature	80.0...110.0 °C	---

Evaluation: Display group 12, display zone 1 - status of glow plug system

Note

Significance of figures in 8-digit number block for operating status of glow plug system:

Significance if display = 1	
Display shows	Glow plug system status
0000 0000	Waiting for coolant temperature
0001 0000	Pre-glow
1011 0000	Post-glow
1111 0000	Intermediate glow
0011 0000	Preparing to glow
1011 0001	Waiting for post-glow
1111 0001	Waiting for intermediate glow
0000 0001	Waiting for ECO (economy) start request
0101 0000	No glow period
1000 0000	No start glow
1111 1111	No glow
0111 0000	Start glow
1101 0000	No post-glow

5.3.9 Display group 13 - Smooth running regulation 1

Test prerequisites

- Engine running at idling speed.
- Engine warm, coolant temperature not below 80 °C.
- Intake air temperature < 40 °C.



Display zone	Operating condition or component	Specification	Evaluation
1	Quantity injected for smooth running through injector, cylinder 1 -N30-	-2.80...2.80 mg/H	⇒ page 60
2	Quantity injected for smooth running through injector, cylinder 2 -N31-	-2.80...2.80 mg/H	⇒ page 60
3	Quantity injected for smooth running through injector, cylinder 3 -N32-	-2.80...2.80 mg/H	⇒ page 60
4	Quantity injected for smooth running through injector, cylinder 4 -N33-	-2.80...2.80 mg/H	⇒ page 60

Evaluation: Display group 13, display zones 1...4 - idling speed smooth running control

- ◆ The injection system has an idling speed smooth running control function. There may be differences in performance between the individual cylinders (component tolerances, jet flow rate, compressions, etc.) which are recognised and compensated for by selective injection quantities.
- ◆ The detection at idling speed is via the signal from the engine speed sender. If the signals are delivered at the same rhythm then all cylinders work the same. If one cylinder is weaker then the crankshaft takes longer for the next half revolution. Conversely a more powerful cylinder will accelerate the crankshaft so that less time is needed for the half revolution.
- ◆ If the engine control unit detects a difference, then the relevant cylinder is immediately given more or less fuel, until the engine runs "smoothly" again.
- ◆ + ... mg/H: The respective cylinder is less powerful and is therefore supplied with more fuel.
- ◆ - ... mg/H: The respective cylinder is more powerful and is therefore supplied with less fuel.

5.3.10 Display group 20 - Rail quantities 3

Test prerequisites

- Engine running at idling speed.
- Engine warm, coolant temperature not below 80 °C.
- Intake air temperature < 40 °C.

Display zone	Operating condition or component	Specification	Evaluation
1	Engine speed	760...940 rpm	---
2	High-pressure fuel system (specified)	170...350 bar	---
3	High-pressure fuel system (actual)	170...350 bar	⇒ page 61
4	High-pressure fuel regulating valve	15...30 %	⇒ page 61



Evaluation: Display group 20, display zone 3 - high-pressure fuel system

Display shows	Possible cause of fault	Fault remedy
Deviation from specification	<ul style="list-style-type: none"> ◆ Defective fuel pressure sender -G247- ◆ Fuel pressure regulating valve -N276- defective ◆ Defective fuel metering valve -N290- ◆ Defective fuel pump 	<ul style="list-style-type: none"> - -G247- Check. ⇒ page 235 - -N276- Check. ⇒ page 232 - -N290- Check. ⇒ page 229 - -V393- Check. ⇒ page 179

Evaluation: Display group 20, display zone 4 - regulating valve for high-pressure fuel system

Display shows	Possible cause of fault	Fault remedy
Deviation from specification	<ul style="list-style-type: none"> ◆ Fuel pressure regulating valve -N276- defective 	<ul style="list-style-type: none"> - -N276- Check. ⇒ page 232

5.3.11 Display group 30 - Pedal value sender

Test prerequisites

- Engine running at idling speed.
- Engine warm, coolant temperature not below 80 °C.
- Intake air temperature < 40 °C.

Display zone	Operating condition or component	Specification	Evaluation
1	Accelerator, sender voltage 1	0.67...0.83 V	---
2	Accelerator, sender voltage 2	0.25...0.5 V	---
3	Accelerator switch position	---	---
4	Accelerator position	0...100 %	⇒ page 61

Evaluation: Display group 30, display zone 4 - accelerator position

Display shows	Possible cause of fault	Fault remedy
1.0...100.0 %	<ul style="list-style-type: none"> ◆ accelerator position sender -G79- defective ◆ Open circuit to -G79- 	<ul style="list-style-type: none"> - -G79- Check. ⇒ page 180

5.3.12 Display group 34 - Charge air pressure sender

Test prerequisites



- Engine running at idling speed.
- Engine warm, coolant temperature not below 80 °C.
- Intake air temperature < 40 °C.

Display zone	Operating condition or component	Specification	Evaluation
1	Engine speed	760...940 rpm	---
2	Charge pressure positioner (specified)	90...100 %	---
3	Charge pressure positioner (actual)	90...100 %	⇒ page 62
4	Charge pressure positioner, actuation	90...100 %	⇒ page 62

Evaluation: Display group 34, display zone 3 - charge pressure control

Display shows	Possible cause of fault	Fault remedy
Deviation from specification	<ul style="list-style-type: none"> ◆ Position sender for charge pressure positioner -G581- defective ◆ Leaks between turbocharger and engine (charge air routing) ◆ Charge pressure control defective 	<ul style="list-style-type: none"> – Checking charge pressure control ⇒ page 192. – -G581- Check. ⇒ page 202

Evaluation: Display group 34, display zone 4 - charge pressure control

Display shows	Possible cause of fault	Fault remedy
Deviation from specification	<ul style="list-style-type: none"> ◆ Position sender for charge pressure positioner -G581- defective ◆ Leaks between turbocharger and engine (charge air routing) ◆ Charge pressure control defective 	<ul style="list-style-type: none"> – Checking charge pressure control ⇒ page 192. – -G581- Check. ⇒ page 202

5.3.13 Display group 99 - Exhaust gas temperature sender

Test prerequisites

- Engine running at idling speed.
- Engine warm, coolant temperature not below 80 °C.
- Intake air temperature < 40 °C.



Display zone	Operating condition or component	Specification	Evaluation
1	Engine speed	760...940 rpm	---
2	Exhaust gas temperature before turbo-charger	80...300 °C	⇒ page 63
3	---	---	---
4	Exhaust gas temperature before particu-late filter	80...200 °C	---

Evaluation: Display group 99, display zone 2 - exhaust gas temperature

Display shows	Possible cause of fault	Fault remedy
Deviation from specification	♦ Defective exhaust gas tem-perature sender 1 -G235-	- -G235- Check. ⇒ page 204

5.3.14 Display group 100 - Particulate filter, exhaust gas temperature, pressure differentials

Test prerequisites

- Engine running at idling speed.
- Engine warm, coolant temperature not below 80 °C.
- Intake air temperature < 40 °C.

Display zone	Operating condition or component	Specification	Evaluation
1	Exhaust gas temperature before particu-late filter	100...250 °C	⇒ page 63
2	Exhaust gas temperature after particu-late filter	100...250 °C	⇒ page 63
3	Particulate filter, pressure differentials (adapted)	0...20 mbar	⇒ page 64
4	Particulate filter, pressure differentials (actual offset figure)	0 mbar	---

Evaluation: Display group 100, display zone 1 - exhaust gas temperature

Display shows	Possible cause of fault	Fault remedy
Deviation from specification	♦ Defective exhaust gas tem-perature sender 3 -G495-	- -G495- Check. ⇒ page 275

Evaluation: Display group 100, display zone 2 - exhaust gas temperature



Display shows	Possible cause of fault	Fault remedy
Deviation from specification	♦ Defective exhaust gas temperature sender 4 -G648-	– -G648- Check. ⇒ page 277

Evaluation: Display group 100, display zone 3 - pressure differentials

Display shows	Possible cause of fault	Fault remedy
Deviation from specification	♦ Defective exhaust gas pressure sensor 1 -G450-	– -G450- Check. ⇒ page 280

5.3.15 Display group 106 - Particulate filter regeneration 6

Test prerequisites

- Engine running at idling speed.
- Engine warm, coolant temperature not below 80 °C.
- Intake air temperature < 40 °C.

Display zone	Operating condition or component	Specification	Evaluation
1	---	---	---
2	Particulate filter, fuel consumption since last regeneration	---	---
3	Particulate filter, kilometres since last regeneration	---	---
4	Particulate filter, time since last regeneration	---	---

5.3.16 Display group 108 - Particulate filter regeneration 8

Test prerequisites

- Engine running at idling speed.
- Engine warm, coolant temperature not below 80 °C.
- Intake air temperature < 40 °C.

Display zone	Operating condition or component	Specification	Evaluation
1	Particulate filter, oil/ash volume	0...175 ml	⇒ page 65
2	Particulate filter, soot mass (calculated)	0...40 g	⇒ page 65
3	Particulate filter, soot mass (measured)	0...40 g	⇒ page 65
4	---	---	---



Evaluation: Display group 108, display zone 1 - particulate filter, regeneration

Display shows	Possible cause of fault	Fault remedy
Higher than specification	◆ Soot saturation too high	– Renew particulate filter ⇒ page 282

Evaluation: Display group 108, display zone 2 - particulate filter, regeneration

Display shows	Possible cause of fault	Fault remedy
Higher than specification	◆ Calculated soot saturation too high	– Renew particulate filter ⇒ page 282

Evaluation: Display group 108, display zone 3 - particulate filter, regeneration

Display shows	Possible cause of fault	Fault remedy
Higher than specification	◆ Measured soot mass too high	– Renew particulate filter ⇒ page 282

5.4 Evaluating data blocks at full load/throttle

Observe prerequisites for measurements at full load/throttle
⇒ page 65.

Display group:

- ◆ 1 - Quantity injected ⇒ page 66,
- ◆ 3 - Exhaust gas recirculation ⇒ page 67,
- ◆ 8 - Torque limit 1 ⇒ page 68,
- ◆ 11 - Charge pressure control ⇒ page 68,

5.4.1 Prerequisites for measurements at full load/throttle

Always follow safety precautions ⇒ page 52.

Reading data block ⇒ page 52.

 **Note**

Due to the various installation possibilities for an industrial engine, first check that a full load/throttle measurement is possible.

- Increase engine speed from approx. 1500 rpm under full throttle (accelerator position sender on full throttle stop).
- Have a second person read off the values at approx. 3000 rpm,



- Terminate diagnosis function.
- Switch off ignition.

5.4.2 Display group 1 - Quantity injected

Note

- ◆ When checking, accelerate engine from 1500 rpm at full throttle. Observe prerequisites for measurements at full load/throttle ⇒ [page 65](#).
- ◆ The measured values must be read (2nd person required) when the revolutions reach 2600 rpm.

Test prerequisites

- Engine warm, coolant temperature not below 80 °C
- Engine speed 2800...3200 rpm
- Engine in full load/throttle mode

Display zone	Operating condition or component	Specification	Evaluation
1	Engine speed	2800...3200 rpm	---
2	Average quantity injected	40.0...60.0 mg/H	⇒ page 66
3	High-pressure fuel system (actual)	1200.0...1700.0 bar	---
4	Coolant temperature	80.0...110.0 °C	---

Evaluation: Display group 1, display zone 2 - quantity injected

Display shows	Possible cause of fault	Fault remedy
Less than specification	◆ Injector (cylinder 1...4) -N30...N33- defective	- -N30...N33- Check. ⇒ page 241
Higher than specification	◆ Engine too cold	- Run engine at increased speed to warm up, and repeat test
	◆ Shortage of fuel ◆ Air in fuel system	- Check fuel supply ⇒ page 172 , Removing and installing parts of fuel supply system - Bleeding fuel system ⇒ page 226
	◆ Injector (cylinder 1...4) -N30...N33- defective	- -N30...N33- Check. ⇒ page 241



5.4.3 Display group 3 - Exhaust gas recirculation

i *Note*

- ◆ When checking, accelerate engine from 1500 rpm at full throttle. Observe prerequisites for measurements at full load/throttle ⇒ [page 65](#).
- ◆ The measured values must be read (2nd person required) when the revolutions reach 2600 rpm.

Test prerequisites

- Engine warm, coolant temperature not below 80 °C
- Engine speed 2800...3200 rpm
- Engine in full load/throttle mode

Display zone	Operating condition or component	Specification	Evaluation
1	Engine speed	2800...3200 rpm	---
2	Intaken air mass (specified):	450...950 mg/stroke	---
3	Intaken air mass (actual):	Approx. intaken air mass (specified)	⇒ page 67
4	Duty cycle of exhaust gas recirculation valve	80...100 %	⇒ page 67

Evaluation: Display group 3, display zone 3 - intaken air mass (actual)

Display shows	Possible cause of fault	Fault remedy
Less than specification	◆ Excessive exhaust gas recirculation	– Check exhaust gas recirculation system ⇒ page 269
	◆ Unmetered air	– Check intake system for leaks
Higher than specification	◆ Engine too cold	– Run engine at increased speed to warm up and repeat test
	◆ Insufficient exhaust gas recirculation	– Short burst of throttle
	◆ Air mass meter -G70- defective	– -G70- Check. ⇒ page 253

Evaluation: Display group 3, display zone 4 - duty cycle of commencement of injection valve

Display shows	Possible cause of fault	Fault remedy
Less than specification	◆ Excessive exhaust gas recirculation	– Check exhaust gas recirculation system ⇒ page 269
	◆ Unmetered air	– Check intake system for leaks



5.4.4 Display group 8 - Torque limit 1

i Note

- ♦ When checking, accelerate engine from 1500 rpm at full throttle. Observe prerequisites for measurements at full load/throttle ⇒ [page 65](#).
- ♦ The measured values must be read (2nd person required) when the revolutions reach 2600 rpm.

Test prerequisites

- Engine warm, coolant temperature not below 80 °C
- Engine speed 2800...3200 rpm
- Engine in full load/throttle mode

Display zone	Operating condition or component	Specification	Evaluation
1	Engine speed	2800...3200 rpm	---
2	Desired torque	xxx Nm	---
3	Torque limit	xxx Nm	---
4	Smoke limit	xxx Nm	---

5.4.5 Display group 11 - Charge pressure control

i Note

- ♦ When checking, accelerate engine from 1500 rpm at full throttle. Observe prerequisites for measurements at full load/throttle ⇒ [page 65](#).
- ♦ The measured values must be read (2nd person required) when the revolutions reach 2600 rpm.

Test prerequisites

- Engine warm, coolant temperature not below 80 °C
- Engine speed 2800...3200 rpm
- Engine in full load/throttle mode

Display zone	Operating condition or component	Specification	Evaluation
1	Engine speed	2800...3200 rpm	---
2	Charge pressure (specified)	2100...2300 mbar	---
3	Charge pressure (actual)	2100...2300 mbar	⇒ page 68
4	Duty cycle of charge pressure control solenoid valve	20...60 %	---

Evaluation: Display group 11, display zone 3 - charge pressure (actual)



Display shows	Possible cause of fault	Fault remedy
Less than specification	<ul style="list-style-type: none"> ◆ Leaks between turbocharger and engine (charge air routing) ◆ Charge pressure control defective 	<ul style="list-style-type: none"> – Checking charge air system for leaks ⇒ page 190 – Checking charge pressure control ⇒ page 192.
Higher than specification	<ul style="list-style-type: none"> ◆ Charge pressure control defective ◆ Turbocharger defective 	<ul style="list-style-type: none"> – Checking charge pressure control ⇒ page 192.
	<ul style="list-style-type: none"> ◆ Charge air pressure sender -G31- defective 	<ul style="list-style-type: none"> – -G31- Check. ⇒ page 199



10 – Removing and installing engine

1 Removing and installing engine

Special tools and workshop equipment required

- ◆ Drip tray -V.A.G 1306- or drip tray -VAS 6208-
- ◆ Torque wrench (5...50 Nm) -V.A.G 1331-
- ◆ Torque wrench (40...200 Nm) -V.A.G 1332-
- ◆ Spring-type clip pliers -VAS 5024-

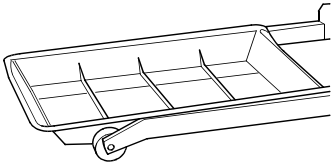
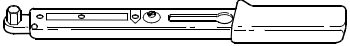
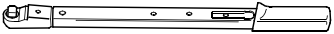
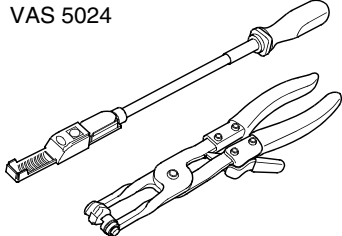
<p>V.A.G 1306</p> 	<p>V.A.G 1331</p> 
<p>V.A.G 1332</p> 	<p>VAS 5024</p> 
	<p>W10-0074</p>

Not illustrated:

- ◆ Lifting tackle -3033-
- ◆ Support clamp -VW 313-
- ◆ Hose clamps up to Ø 25 mm -3094-
- ◆ Engine and gearbox support -VAS 6095-
- ◆ Workshop hoist -V.A.G 1202 A- or workshop hoist -VAS 6100-
- ◆ Container for removed parts -V.A.G 1698-
- ◆ Engine bung set -VAS 6122-
- ◆ Transportation lock -T10404-
- ◆ Grease -G 000 100-
- ◆ Cable ties



Notes on removing ⇒ page 71.

Securing engine to assembly stand ⇒ page 72.

Notes on installing ⇒ page 72

Specified torques ⇒ page 73.

Additional information and assembly work for assemblies with an air conditioner ⇒ page 73.

1.1 Notes on removing

Note

The following procedures contain basic notes for the removal and installation of industrial engines, more specific information is not possible due to the various configurations of installing an industrial engine.

Procedure

WARNING!

Due to the cramped conditions, note the following when carrying out repairs:

- ◆ ***Route all the various lines (e.g. for fuel, hydraulics, coolant and refrigerant, brake fluid and vacuum) and electrical wiring in their original positions.***
- ◆ ***Ensure that there is sufficient clearance to all moving or hot components.***

Note

- ◆ *All cable ties which are opened or cut through when the engine is removed must be replaced in the same position when the engine is installed.*
- ◆ *To prevent damage to removed components, place them in the container for removed parts -V.A.G 1698-.*
- ◆ *Some components cannot be removed, or removed only with difficulty, with the engine installed. Therefore, you should determine all defective components before removing engine and renew them while engine is removed.*
- Before removal, read fault memory of engine control unit ⇒ page 7, Reading fault memory.
- With ignition switched off, disconnect earth strap from battery.
- Pull fuel supply hose and fuel return hose off engine.
- Seal lines so that fuel system is not contaminated by dirt.
- Observe rules for cleanliness ⇒ page 208
- Drain coolant ⇒ page 159.
- Pull coolant hoses off radiator.
- Pull off all cooling system hoses to engine using spring-type clip pliers -VAS 5024-.



- Disconnect all electric wires from gearbox, alternator and starter and lay to side.
- Pull off or disconnect all other electrical connections as necessary from engine and lay to side.
- Pull off necessary vacuum and breather hoses from engine.

! *Caution!*

Danger of damaging decoupling element between particulate filter and NOx storage catalytic converter. When removing and installing:

- ◆ ***Do not bend decoupling element more than 10°.***
 - ◆ ***Install decoupling element so that it is not under tension.***
 - ◆ ***Take care not to damage wire mesh on decoupling element.***
 - ◆ ***The decoupling element of the exhaust pipe must be secured with transportation lock -T10404- to stop overstretching.***
- Release connecting clamp for front exhaust pipe/particulate filter.

Assemblies with air conditioning system:

- Observe additional information and installation work
⇒ [page 73](#).

1.2 Securing engine to assembly stand

Before carrying out repair work, secure engine on engine and gearbox support -VAS 6095- using universal mounting -VAS 6095/1-.

Procedure

- Attach lifting tackle -3033- as follows and raise engine using workshop hoist -V.A.G 1202 A- or workshop hoist -VAS 6100-.

Flywheel end:

- Position 4.

Vibration damper end:

- Position 8.
- Secure engine on engine and gearbox support -VAS 6095- using universal mounting -VAS 6095/1-.

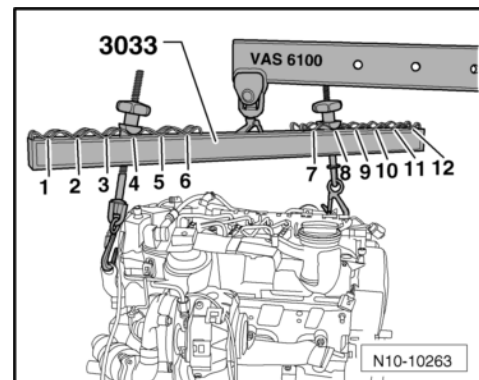

1.3 Notes on installing

Installation is carried out in the reverse order. When installing, note the following:

Procedure

- Check clutch release bearing for wear and replace if necessary.



- Lightly lubricate clutch release bearing, release bearing guide sleeve and splines on input shaft with grease -G 000 100-.
- Check whether dowel sleeves for aligning engine and gearbox are fitted in cylinder block and install if necessary.
- Screw in all bolts on assembly mountings by hand approx. 5...6 turns.
- Align assembly mountings stress-free by rocking.
- Fill with coolant ⇒ [page 159](#).
- Then read fault memory of engine control unit and clear fault memory if necessary ⇒ [page 7](#), Clearing fault memory.

1.4 Specified torques

Threaded connection	Specified torque	
On cylinder block.	M6	10 Nm
	M7	15 Nm
	M8	20 Nm
	M10	40 Nm
	M12	65 Nm ¹⁾

¹⁾ Specified torque for M12 flange bolts: 75 Nm

1.5 Additional information and assembly work for assemblies with an air conditioner



WARNING!

The air conditioner refrigerant circuit must not be opened.



Note

- ◆ *The opening of the refrigerant circuit can only be carried out in workshops, which have trained personnel and the necessary range of tools and workshop equipment.*
- ◆ *To prevent damage to condenser and also to refrigerant lines/hoses, ensure that the lines and hoses are not stretched, kinked or bent.*

To facilitate removing and installing engine without opening refrigerant circuit:

- Unscrew retaining clamp(s) for refrigerant lines.
- Remove poly V-belt ⇒ [page 76](#).
- Remove air conditioner compressor and secure to side so that the refrigerant lines and hoses are relieved ⇒ [page 75](#), Assembly overview - poly V-belt drive.



13 – Crankshaft group

1 Dismantling and assembling engine

Note

- ◆ *Before carrying out repair work, secure engine on engine and gearbox support -VAS 6095- using universal mounting -VAS 6095/1-.*
- ◆ *All bearing and running surfaces must be oiled before assembly.*

Caution!

Finding metal shavings or a large quantity of small metal particles during engine repair could indicate that the crankshaft bearings or conrod bearings are damaged. To prevent this from causing further damage, perform the following on completion of repairs:

- ◆ *Thoroughly clean oil passages,*
- ◆ *Renew oil spray jets,*
- ◆ *Renew oil cooler,*
- ◆ *Renew oil filter element.*

Assembly overview - poly V-belt drive ⇒ [page 75](#).

Removing and installing poly V-belt ⇒ [page 76](#).

Checking poly V-belt ⇒ [page 77](#)

Poly V-belt routing ⇒ [page 77](#)

Removing and installing poly V-belt tensioner ⇒ [page 77](#).

Removing and installing ancillary bracket ⇒ [page 78](#).

Assembly overview - toothed belt drive ⇒ [page 80](#).

Cylinder crankcase - Assembly overview ⇒ [page 83](#).



1.1 Assembly overview - poly V-belt drive

1 - Belt pulley/vibration damper

- Can only be installed in one position, holes are offset.

2 - 25 Nm

3 - Alternator -C-

- Assembly overview ⇒ [page 292](#)

4 - Ancillary bracket

- For alternator and, if fitted, air conditioner compressor
- Removing and installing ⇒ [page 78](#).

5 - 20 Nm + 1/2 turn further (180 °).

- Renew.
- Do not additionally oil or grease the threads and shoulder
- Turning further can be done in several stages.

6 - Poly-V-belt tensioning element

- Swivel to relax poly V-belt ⇒ [page 76](#), Removing and installing poly V-belt.
- Removing and installing tensioning element ⇒ [page 77](#).

7 - Air conditioner compressor

- When installed.

8 - 45 Nm

9 - Dowel sleeve

10 - Poly V-belt

- Mark direction of rotation before removing.
- Do not kink.
- Removing and installing ⇒ [page 76](#).
- Checking for wear ⇒ [page 77](#).

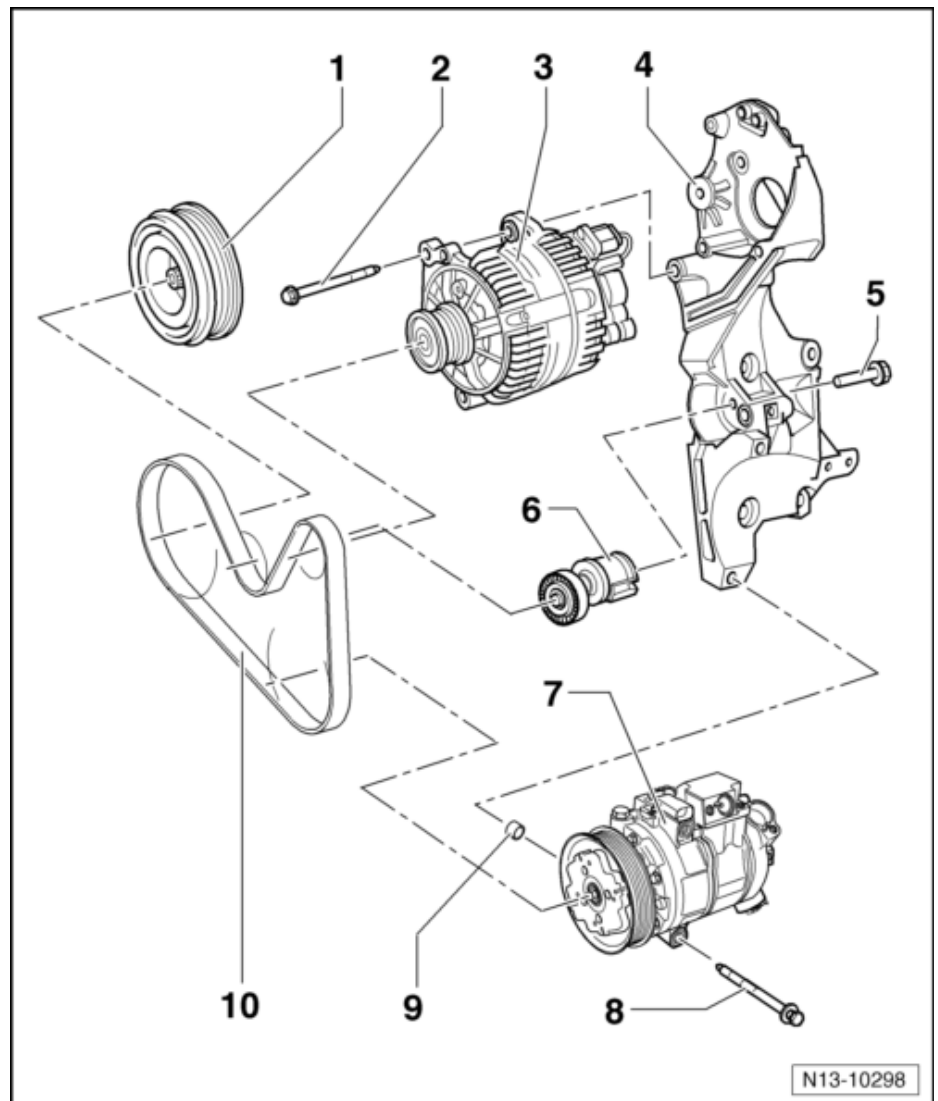



1.2 Removing and installing poly V-belt

Special tools and workshop equipment required

- ◆ Locking pin -T10060 A-

Remove poly V-belt ⇒ [page 76](#).

Install poly V-belt ⇒ [page 76](#).

1.2.1 Removing poly V-belt

- Mark direction of rotation of poly V-belt.
- Turn the tensioner in the direction of the -arrow- to slacken the poly V-belt.
- Align holes -arrows- and lock tensioning element in position with locking pin -T10060 A-.
- Remove poly V-belt.

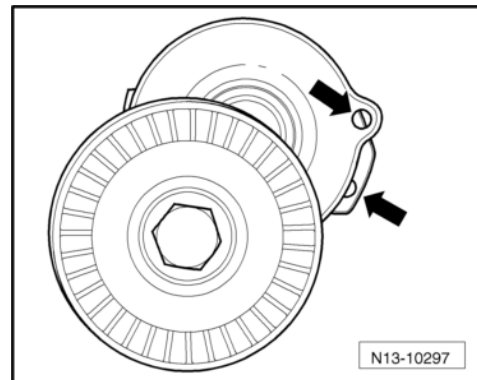
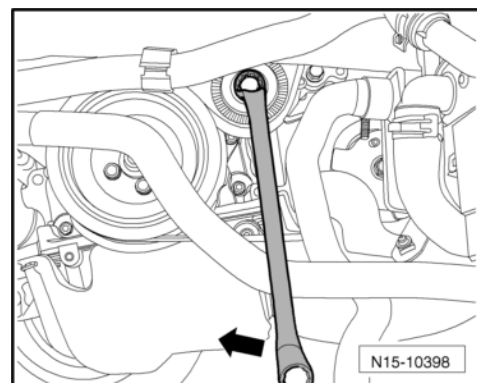
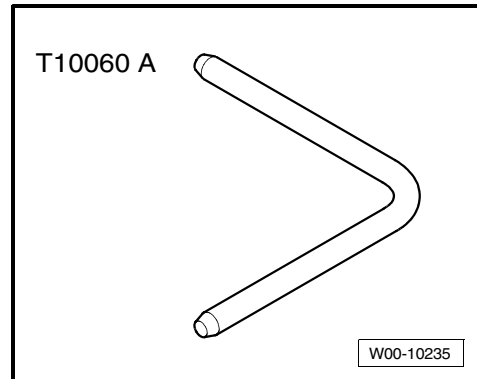

1.2.2 Installing poly V-belt

- Installation is carried out in the reverse order. When installing, note the following:

Note

- ◆ Before installing poly V-belt, make sure all assemblies (alternator, air conditioner compressor) are firmly in position.
- ◆ When fitting poly V-belt, check direction of belt rotation and proper seating of belt in belt pulleys.

- Fit poly V-belt on pulleys.

- 1 - Crankshaft
- 2 - Tensioning element
- 3 - Alternator
- 4 - Air conditioner compressor (if installed)

After completing repairs always:

- Start engine and check belt running.

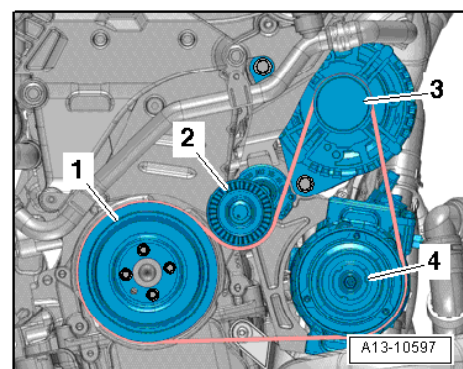



1.3 Poly V-belt routing

Routing with no air conditioner compressor

Routing with air conditioner compressor

1.3.1 Routing with no air conditioner compressor

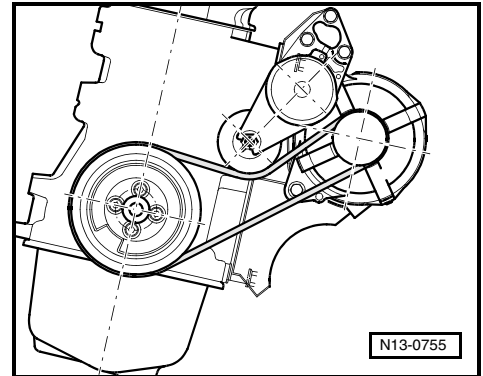

1.3.2 Routing with air conditioner compressor

1.4 Poly V-belt has been checked

Note

It is essential to renew the poly V-belt if a fault is found. This will avoid possible breakdowns or malfunctions.

Test procedure

- Crank engine by hand and check poly V-belt for:
 - ◆ Sub-surface cracks (cracks, core ruptures, cross sectional breaks)
 - ◆ Layer separation (top layer, cord strands)
 - ◆ Base break-up
 - ◆ Fraying of cord strands
 - ◆ Flank wear (material wear, frayed flanks, flank brittleness -glassy flanks-, surface cracks)

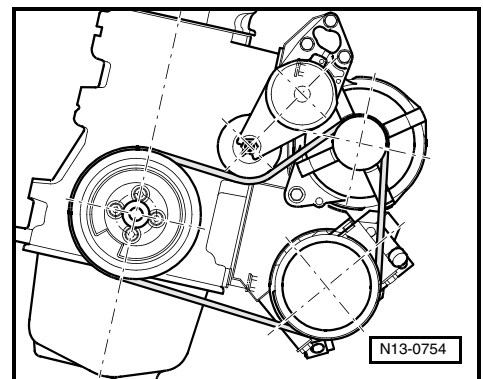

1.5 Removing and installing poly V-belt tensioner

Removing

- Remove poly V-belt ⇒ [page 76](#).
- Loosen clamp -2-, raise retaining clip -1- and remove connecting hose on “cold side”.

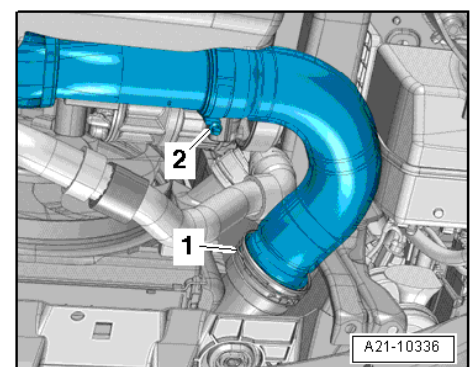



- Unscrew securing bolts -arrows- from charge air pipe and separate connector -1- from charge air pressure sender -G31-.

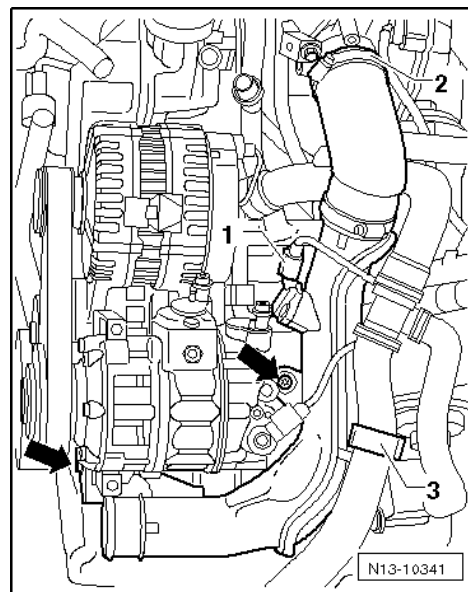

- Open clamp -2-, lay coolant hose -3- to side and remove charge air pipe.

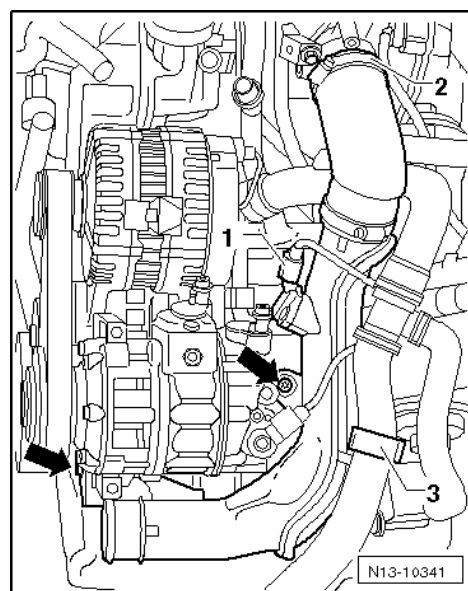

- Unscrew securing bolt -2- and remove poly V-belt tensioner -1-.

Installing

Installation is carried out in the reverse sequence of removal. In the process, note the following:

- ♦ Renew bolt for tensioning element
- ♦ Specified torques ⇒ [page 75](#).
- ♦ Install poly V-belt ⇒ [page 76](#).

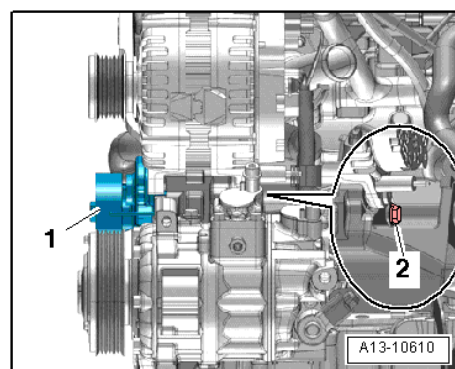

1.6 Removing and installing ancillaries bracket

Removing

- Remove high-pressure pump ⇒ [page 224](#).
- Remove alternator ⇒ [page 292](#).

! WARNING!

The air conditioner refrigerant circuit must not be opened.

- Unscrew air conditioner compressor from ancillaries bracket (if installed) and attach it free-of-stress to a suitable location.
- Unscrew idler rollers -1- and -2- and remove bolt of toothed belt guard -arrow-.

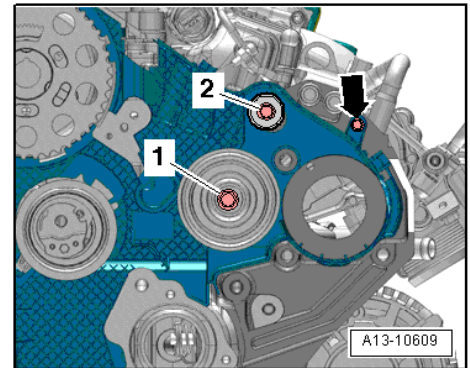

- Unscrew bolts -6...1- and remove ancillaries bracket.

Installing

Installation is carried out in the reverse sequence of removal. In the process, note the following:

- ◆ Take note of any dowel sleeves in ancillary bracket and replace missing ones if necessary.
- ◆ Renew all bolts that must be tightened with specified tightening angle.

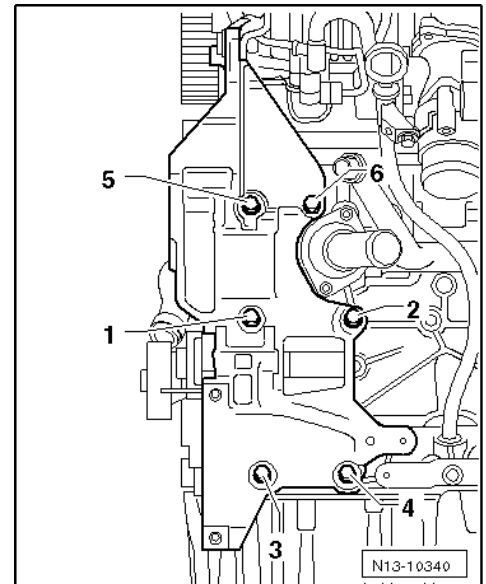



- Tighten securing bolts in sequence -1...6-. Specified torque ⇒ [item 5 on page 75](#).
- Install alternator ⇒ [page 292](#).
- Install high-pressure pump ⇒ [page 224](#).

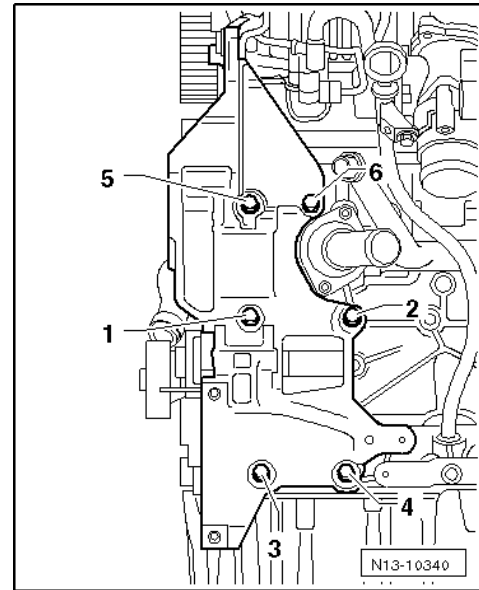

1.7 Assembly overview - toothed belt drive

1 - Toothed belt

- Mark direction of rotation before removing.
- Check for wear.
- Do not kink.
- Removing, installing and tensioning ⇒ [page 117](#)

2 - 120 Nm + 1/4 turn further (90 °).

- Renew.
- Use counterhold tool -3415- to loosen and tighten.
- Do not additionally oil or grease the threads and shoulder
- Turning further can be done in several stages.

3 - Crankshaft toothed belt pulley

4 - 20 Nm

5 - Idler roller

6 - 20 Nm + 1/8 turn further (45 °).

- Renew.

7 - Tensioning roller

- To remove and install, remove engine bracket.

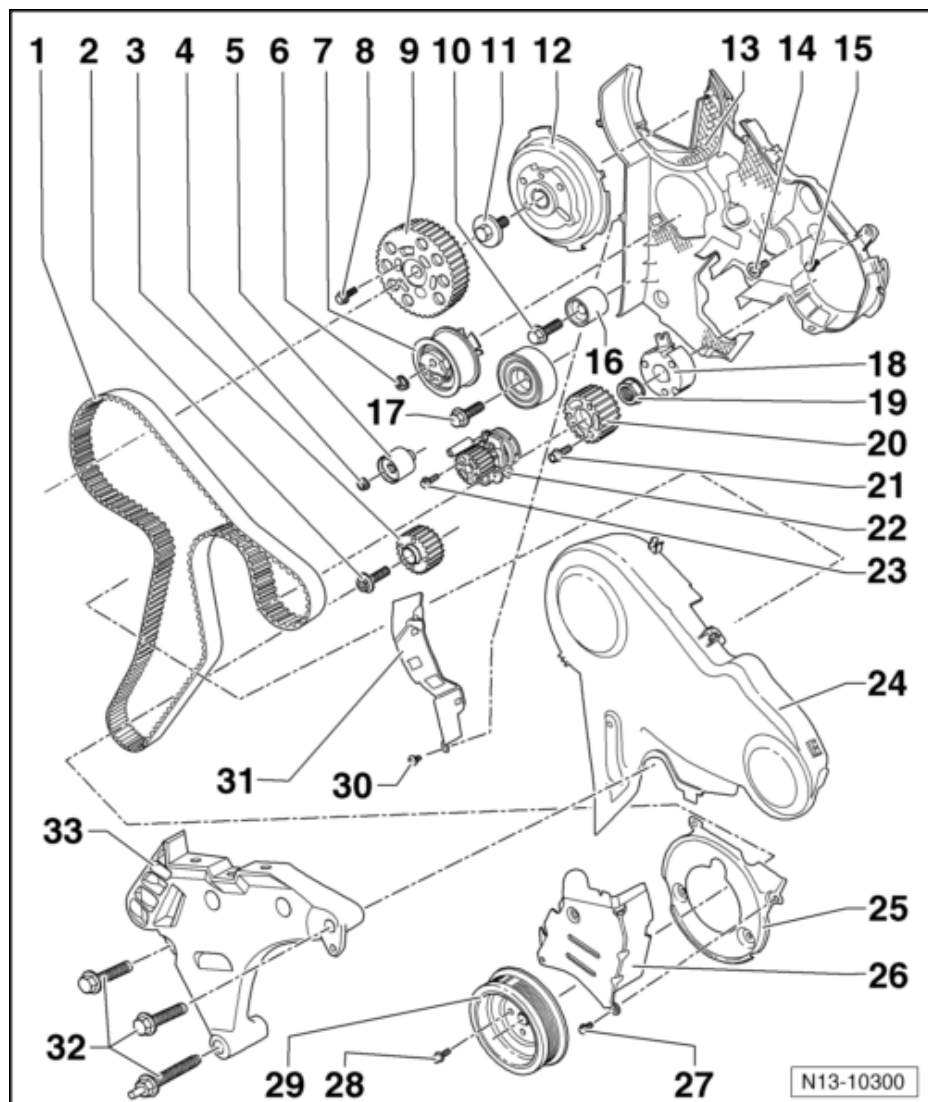



- 8 - 20 Nm + $\frac{1}{4}$ turn further (90 °).
 - Renew.
- 9 - Camshaft pulley
- 10 - 25 Nm
- 11 - 100 Nm
- 12 - Hub
 - Use counterhold tool -T10051- to loosen and tighten.
 - To remove, use puller -T10052-
 - Removing and installing ⇒ [page 138](#) Removing and installing camshafts.
- 13 - Rear toothed belt guard
- 14 - 20 Nm
- 15 - 10 Nm
 - Renew.
- 16 - Idler roller
- 17 - 50 Nm + $\frac{1}{4}$ turn further (90 °).
 - Renew.
- 18 - Hub
 - Use counterhold tool -T10051- to loosen and tighten.
 - To remove, use puller -T40064-.
 - Removing and installing ⇒ [page 224](#).
- 19 - 95 Nm
- 20 - Toothed belt pulley for fuel system high-pressure pump
- 21 - 20 Nm + $\frac{1}{4}$ turn further (90 °).
 - Renew.
- 22 - Coolant pump
 - Removing and installing ⇒ [page 162](#).
- 23 - 15 Nm
- 24 - Toothed belt guard upper part
 - Installing ⇒ [Fig. on page 82](#)
- 25 - Toothed belt guard lower part
- 26 - Toothed belt guard centre part
- 27 - 10 Nm
 - Renew.
- 28 - 10 Nm + $\frac{1}{4}$ turn further (90 °).
 - Renew.
- 29 - Belt pulley/vibration damper
 - Can only be installed in one position, holes are offset.
- 30 - 5 Nm
- 31 - Protective plate
- 32 - 40 Nm + $\frac{1}{2}$ turn further (180 °).
 - Renew.
 - Observe tightening sequence ⇒ [Fig.](#)
- 33 - Engine bracket



Tightening sequence for engine bracket to cylinder block

⚠ **Caution!**

The tightening sequence and specified torques for the engine bracket securing bolts must always be followed. Otherwise the engine bracket can be stressed and it can break.

- First tighten new securing bolts hand-tight in the sequence -1...3-.
- Tighten securing bolts in tightening sequence to specified torque ⇒ **item 32 on page 81**.

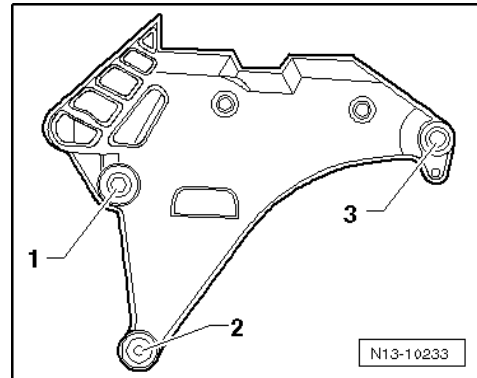

Install toothed belt guard upper part.

- Ensure upper part of toothed belt guard is correctly clipped to cylinder head cover.

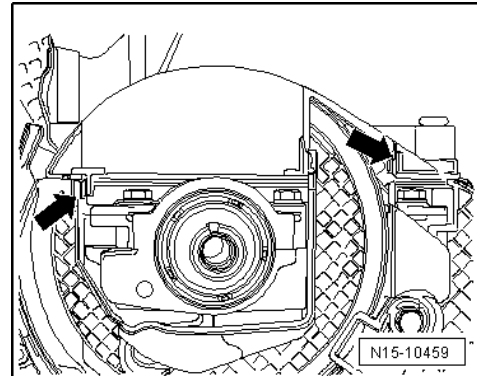



15- Sump

- Clean sealing surface before fitting.
- Install with silicone sealant -D176404 A2-
- Removing and installing ⇒ [page 149](#).

16- 15 Nm

2 Removing and installing sealing flange and flywheel



Note

Before carrying out repair work, secure engine on engine and gearbox support -VAS 6095- using universal mounting -VAS 6095/1-.

Assembly overview - sealing flange and flywheel ⇒ [page 85](#).

Renewing crankshaft oil seal - belt pulley end ⇒ [page 86](#).

Removing and installing crankshaft sealing flange - belt pulley end ⇒ [page 88](#).

Renewing crankshaft sealing flange - flywheel end
⇒ [page 90](#).

Removing and installing engine speed sender -G28-
⇒ [page 97](#).

2.1 Assembly overview - sealing flange and flywheel

1 - Crankshaft oil seal - belt pulley end

- Do not additionally oil or grease the oil seal sealing lip.
- Before installing, remove oil residue from crankshaft journal with a clean cloth
- Renew ⇒ [page 86](#).

2 - Crankshaft sealing flange - belt pulley end

- Must seat on dowel sleeves.
- Removing and installing ⇒ [page 88](#).

3 - Cylinder block

- Removing and installing crankshaft ⇒ [page 98](#)
- Dismantling and assembling pistons and conrods ⇒ [page 101](#).

4 - 60 Nm + 1/4 turn further (90 °).

5 - Flywheel

- To remove and install flywheel, lock with counterhold tool -3067-.

6 - Intermediate plate

- Must seat on dowel sleeves.
- Do not damage or bend when assembling.

7 - 15 Nm

- Renew.

8 - Crankshaft sealing flange - flywheel end

- With oil seal
- Do not additionally oil or grease the oil seal sealing lip.
- Before installing, remove oil residue from crankshaft journal with a clean cloth
- Renew complete with oil seal and sender wheel only
- Renew ⇒ [page 90](#).

9 - Engine speed sender -G28-, 5 Nm

- Checking ⇒ [page 242](#).
- Loosen and tighten using commercially available ball-ended socket
- Removing and installing ⇒ [page 97](#).

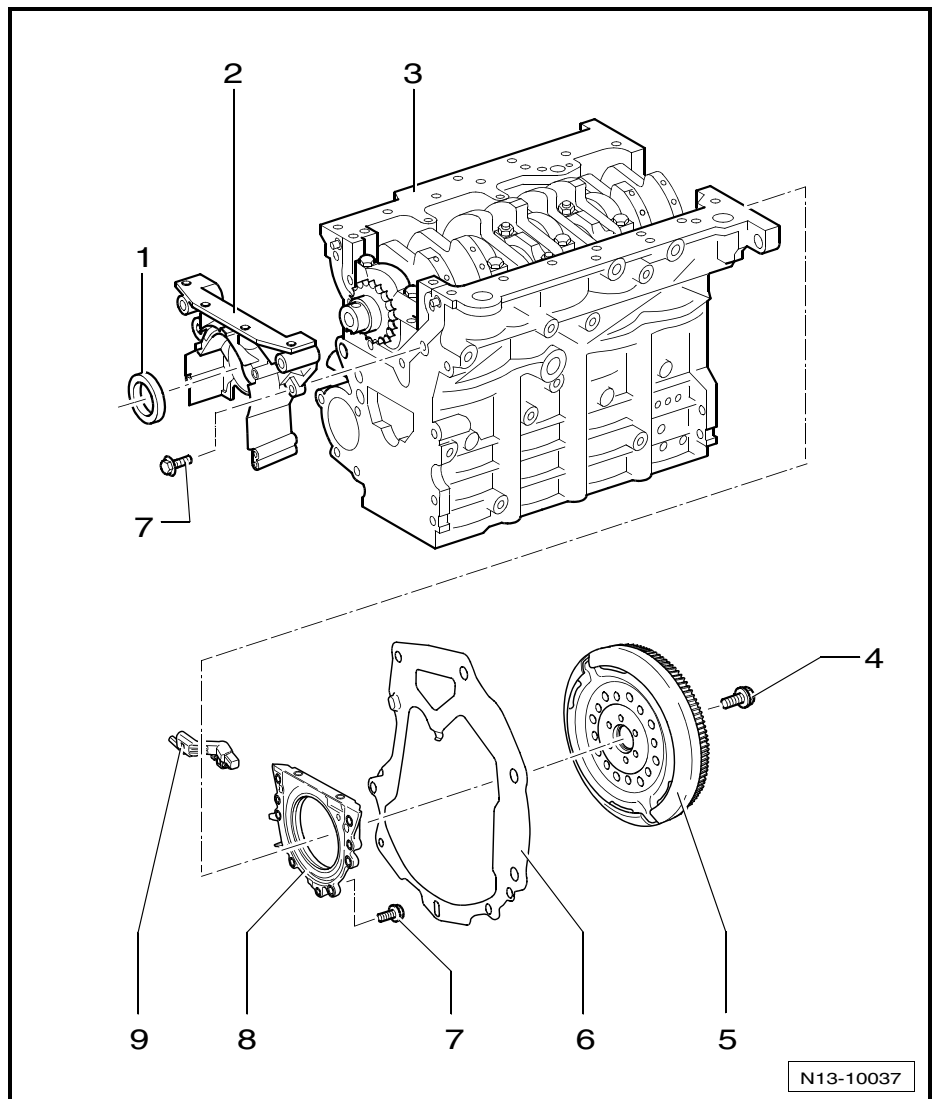



2.2 Renewing crankshaft oil seal on belt pulley end

Special tools and workshop equipment required

- ◆ Oil seal extractor -3203-
- ◆ Counterhold -3415-
- ◆ Fitting tool -T10053-
- ◆ Torque wrench (5...50 Nm) -V.A.G 1331-
- ◆ Torque wrench (40...200 Nm) -V.A.G 1332-

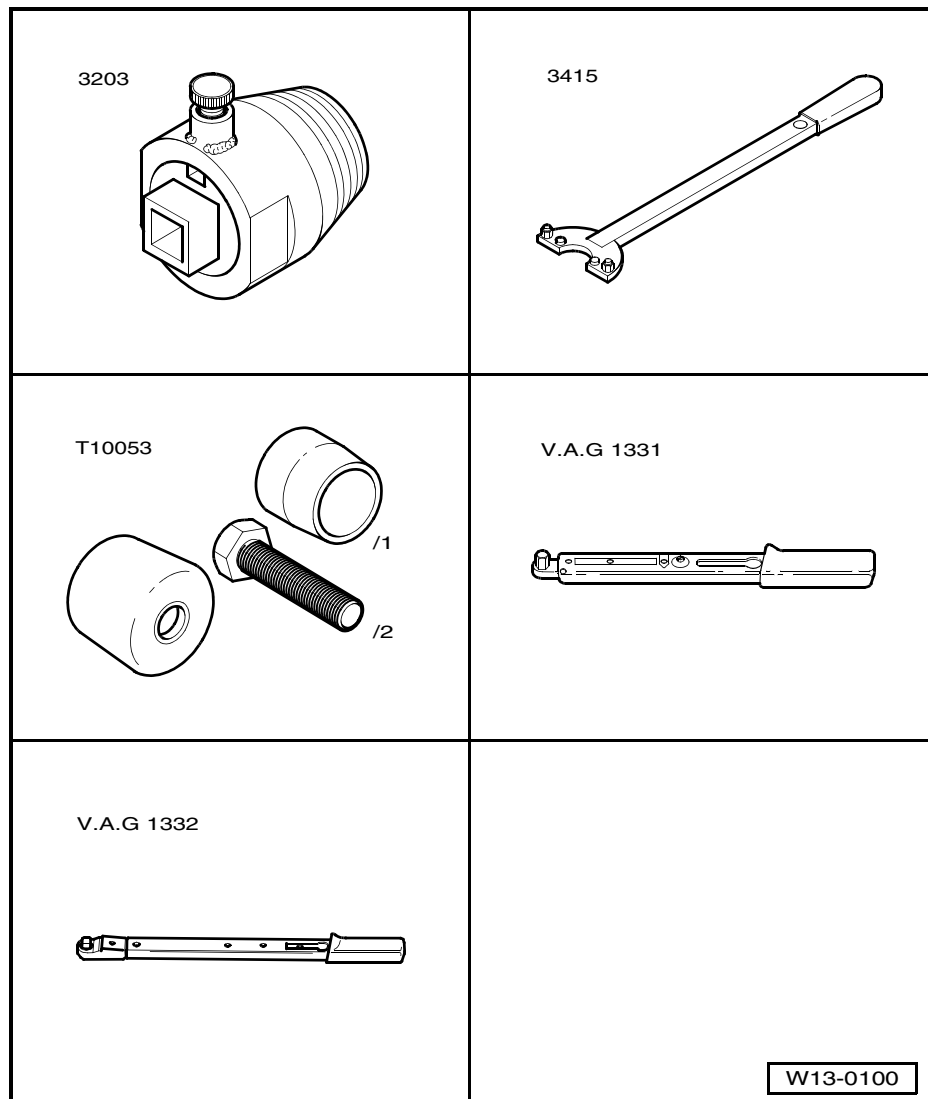

Removing ⇒ [page 86](#).

Installing ⇒ [page 87](#).

2.2.1 Removing

- Remove toothed belt ⇒ [page 117](#).
- Remove crankshaft toothed belt pulley. To do this, lock toothed belt pulley using counterhold -3415-.
- To guide oil seal extractor -3203-, screw central bolt by hand fully into crankshaft.
- Unscrew inner part of oil seal extractor two turns (approx. 3 mm) out of outer part and lock with knurled screw.
- Oil threaded head of oil seal extractor.

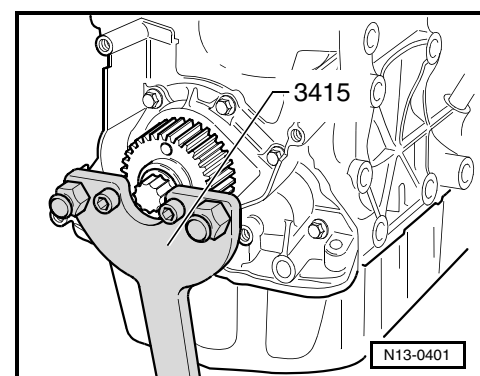



- Using great pressure, screw oil seal extractor as far as possible into oil seal.
- Loosen knurled screw and turn inner part against crankshaft until oil seal is pulled out.

2.2.2 Installing

Note

The oil seal sealing lip must not be additionally oiled or greased.

- Remove oil residue from crankshaft journal using clean cloth.
- Place guide sleeve -T10053/1- onto crankshaft journal.
- Slide oil seal over guide sleeve onto crankshaft journal.
- Press oil seal in onto stop using assembly tool -T10053- and centre bolt.
- Install crankshaft toothed belt pulley. To do this, lock toothed belt pulley using counterhold -3415-.
- Tighten new centre bolt to 120 Nm + 1/4 turn (90 °) further (turning further can be done in several stages).

Note

Thread and shoulder must be free of oil and grease.

- Install and tension toothed belt ⇒ [page 117](#).

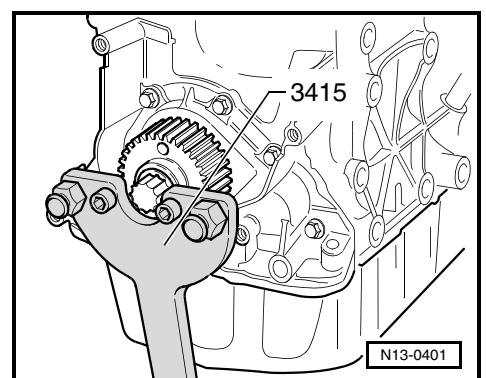
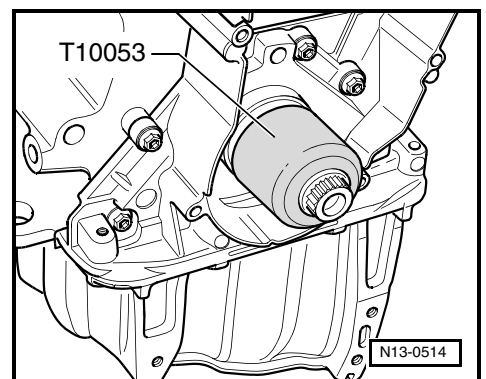
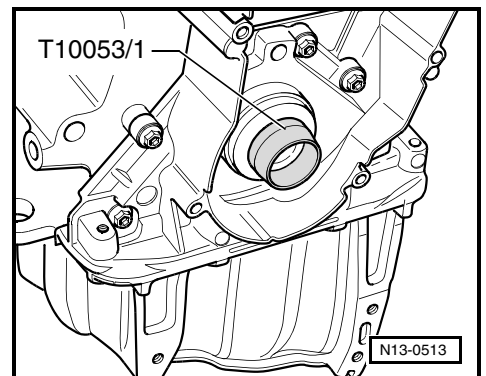
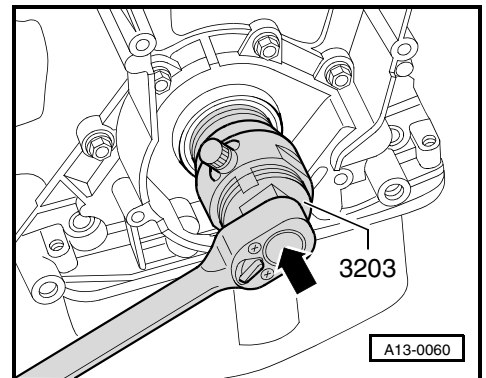





2.3 Removing and installing crankshaft sealing flange - belt pulley end

Special tools and workshop equipment required

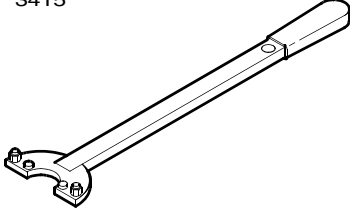
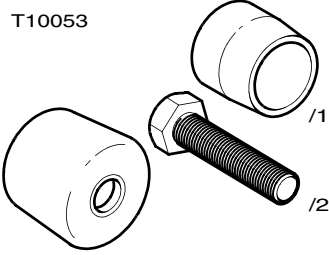
- ◆ Counterhold -3415-
- ◆ Fitting tool -T10053-
- ◆ Torque wrench (5...50 Nm) -V.A.G 1331-
- ◆ Torque wrench (40...200 Nm) -V.A.G 1332-

<p>3415</p> 	<p>T10053</p> 
<p>V.A.G 1331</p> 	<p>V.A.G 1332</p> 
<p style="text-align: right;">W13-0101</p>	

Not illustrated:

- ◆ Silicone sealant -D176404 A-
- ◆ Hand drill with plastic brush attachment
- ◆ Flat scraper
- ◆ Safety goggles

Removing ⇒ [page 88](#).

Installing ⇒ [page 89](#).

2.3.1 Removing

- Remove toothed belt ⇒ [page 117](#).



- Remove crankshaft toothed belt pulley. To do this, lock toothed belt pulley using counterhold -3415-.
- Drain engine oil.

i Note

Observe environmental regulations for disposal.

- Remove sump ⇒ [page 149](#).
- Remove crankshaft sealing flange (belt pulley end).
- Remove sealing flange; if necessary, loosen by applying light blows with a rubber-headed hammer.
- Remove sealant residue on cylinder block with a flat scraper.
- Remove residual sealant from sealing flange using a plastic rotary brush (wear eye protection).
- Clean sealing surfaces. They must be free of oil and grease.

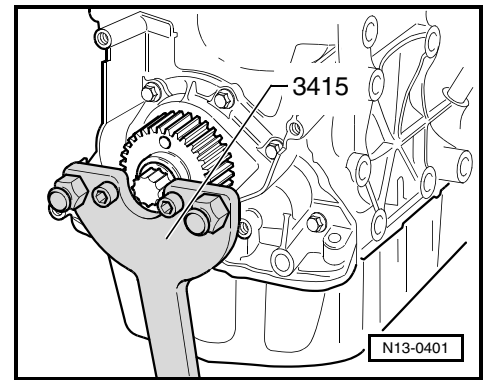

2.3.2 Installing

i Note

- ◆ Note the expiry date of the sealant.
- ◆ The sealing flange must be installed within 5 minutes of applying silicone sealant.
- Cut off tube nozzle at forward marking (approx. 3 mm nozzle Ø).

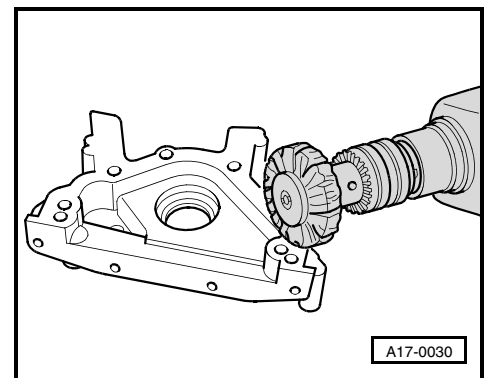

i Note

- ◆ Sealant bead must not be wider than 2...3 mm, because otherwise excess sealant can enter sump and clog strainer in oil pump suction pipe as well as drip onto crankshaft oil seal.
- ◆ Before applying sealant bead, cover sealing surface of oil seal with a clean cloth.

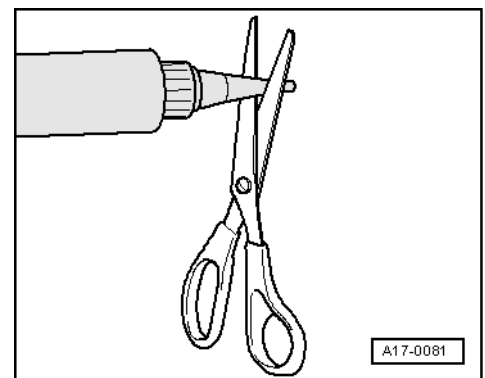

- Apply silicone sealant bead as shown to the clean sealing surface of sealing flange.
- Install sealing flange immediately and tighten all bolts lightly.

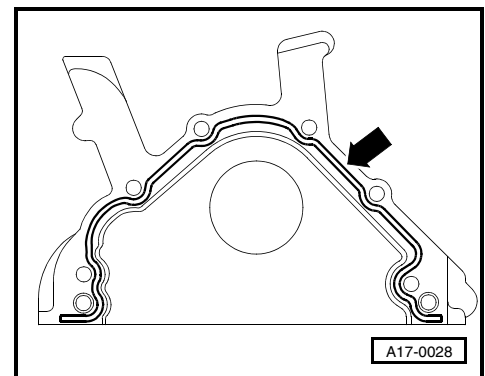

i Note

When fitting sealing flange with oil seal installed use guide sleeve -T10053/1-.

- Tighten securing bolts for sealing flange to 15 Nm using alternate and diagonal sequence.
- Remove excess sealant.
- Install sump ⇒ [page 149](#).



i Note

Sealing compound must dry for approx. 30 minutes after installation. Only then fill with engine oil.

Install crankshaft toothed belt pulley. To do this, lock toothed belt pulley using counterhold -3415-.

Tighten new centre bolt to 120 Nm + 1/4 turn (90 °) further (turning further can be done in several stages).

i Note

Thread and shoulder must be free of oil and grease.

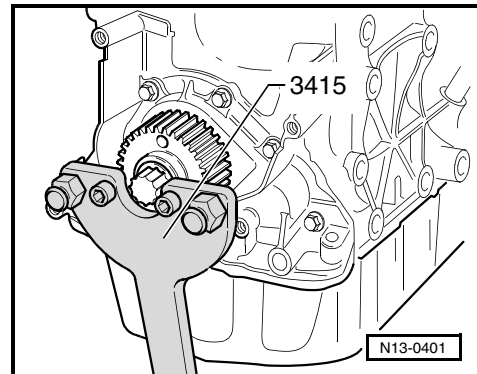

- Install and tension toothed belt => [page 117](#).



2.4 Renewing crankshaft sealing flange - flywheel end

Special tools and workshop equipment required

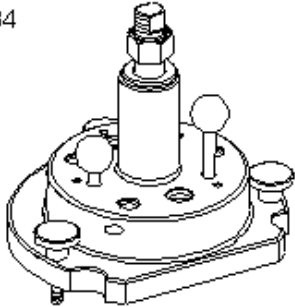
- ◆ Fitting tool -T10134-
- ◆ Torque wrench -V.A.G 1331-
- ◆ Tool insert 24 mm -V.A.G 1332/11-

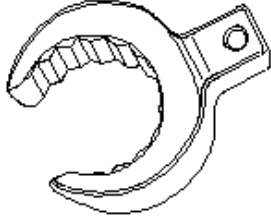
<p>T10134</p> 	<p>V.A.G 1331</p> 
<p>V.A.G 1332/11</p> 	
	<p>W13-10021</p>



Not illustrated

- ◆ Vernier gauge
- ◆ Three hexagon bolts M6 x 35 mm
- ◆ Two hexagon bolts M7 x 35 mm

Pressing out sealing flange with sender wheel ⇒ [page 91](#).

Pressing in sealing flange with sender wheel ⇒ [page 92](#).

A - Assembling seal with sender wheel on assembly tool -T10134- ⇒ [page 92](#).

B - Attaching assembling tool -T10134- with sealing flange on crankshaft flange ⇒ [page 94](#).

C - Bolting assembly tool -T10134- onto crankshaft flange ⇒ [page 95](#).

D - Pressing sender wheel onto crankshaft flange using assembly tool -T10134- ⇒ [page 95](#).

E - Checking sender wheel installation position on crankshaft ⇒ [page 96](#).

F - Re-pressing sender wheel ⇒ [page 97](#).

2.4.1 Pressing out sealing flange with sender wheel

Note

For the sake of clarity, the work is performed with the engine removed.

- Remove flywheel ⇒ [page 85](#), Assembly overview - sealing flange and flywheel.
- Remove intermediate plate.
- Set engine to TDC of cylinder no. 1 ⇒ [page 117](#), Removing and installing toothed belt.
- Drain engine oil.

Note

Observe environmental regulations for disposal.

- Remove sump ⇒ [page 149](#).
- Remove engine speed sender -G28- -arrow- using a commercially available ball-ended hex key socket.
- Unscrew sealing flange securing bolts.

Note

Sealing flange and sender wheel are pressed off the crankshaft together using three M6 x 35 mm bolts.

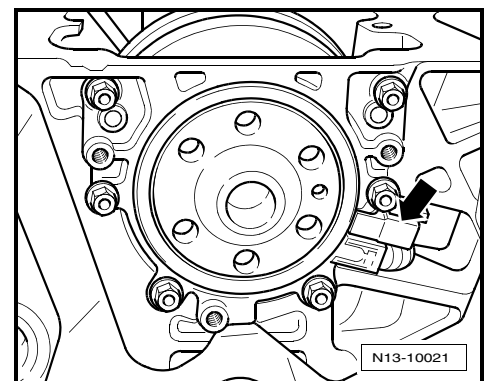



- Screw three M6 x 35 mm bolts into threaded holes 35 mm -arrows- of sealing flange.
- Screw bolts (max. one $\frac{1}{2}$ turn (180 °) per bolt) to sealing flange and press off sealing flange together with sender wheel from crankshaft.

2.4.2 Pressing in sealing flange with sender wheel

Note

- ♦ The sealing flange with a PTFE seal is equipped with a sealing lip support ring. This support ring serves as a fitting sleeve and must not be removed prior to installation.
- ♦ Sealing flange and sender wheel must not be separated or turned after removal from packaging.
- ♦ The sender wheel is held in its installation position on the assembly device -T10134- by a locating pin.
- ♦ Sealing flange and oil seal are one unit and must be replaced together with the sender wheel only.
- ♦ The assembly device -T10134- is held in its position relative to the crankshaft by a guide pin inserted into a hole in the crankshaft.

Fitting tool -T10134-

- A - Clamping surface
- B - Hexagon nut
- C - Assembly housing
- D - Locating pin
- E - Hexagon socket head bolt
- F - Guide pin for diesel engines (black knob)
- G - Guide pin for petrol engines (red knob)

2.4.3 A - Assembling sealing flange with sender wheel on assembly tool -T10134-

- Screw in hexagon nut -B- to just before clamping surface -A- of threaded spindle.

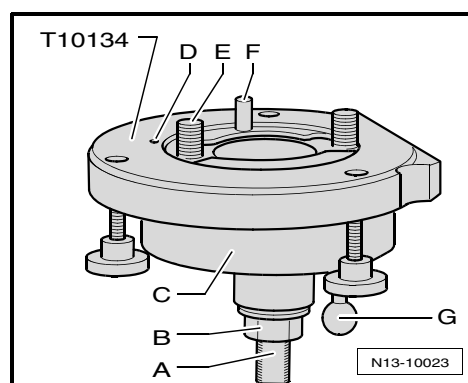
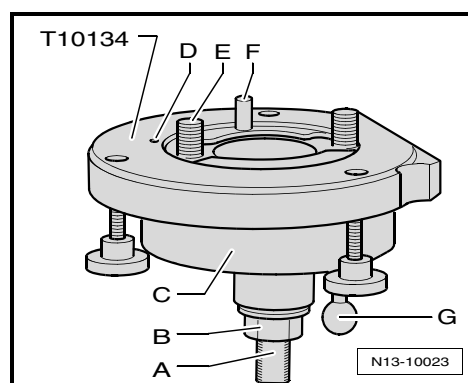
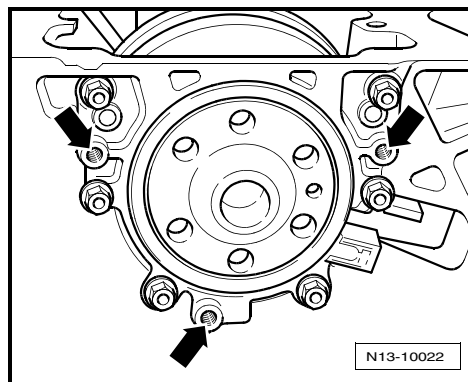

- Clamp assembly device -T10134- in a vice on clamping surface -A- of threaded spindle.
- Press assembly housing -C- downwards so that it lies on hexagon nut -B- -arrow-.

i Note

Inner part of assembly tool and assembly housing must be at same height.

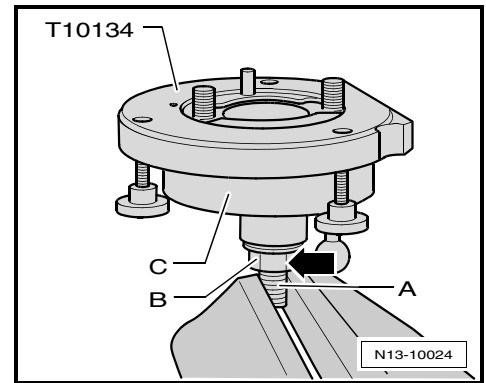

- Remove securing clip -arrow- from new sealing flange.

i Note

The sender wheel must not be taken out of the sealing flange or turned.

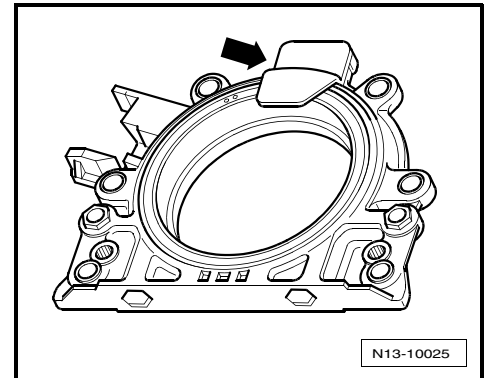

- The locating hole -A- on the sender wheel -C- must align with the marking -B- on the sealing flange.
- Place sealing flange with front side downwards on a clean flat surface.

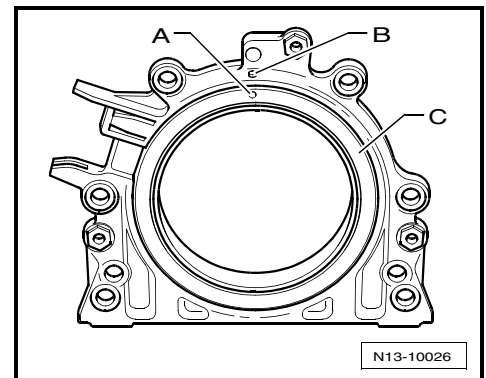

- Push sealing lip support ring -A- downwards in direction of arrow until it lies on flat surface.

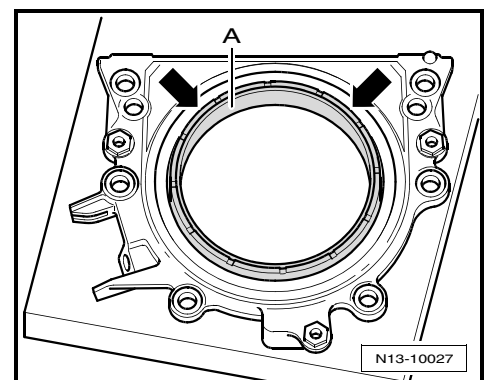



- Upper edge of sender wheel and front edge of sealing flange must align -arrows-.

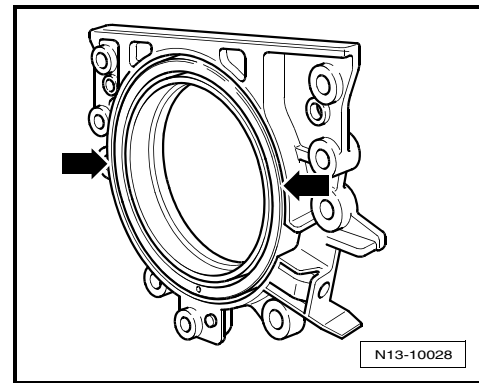

- Place sealing flange with front side on assembly device -T10134- so that locating pin -A- can be inserted in sender wheel hole -A-.

i Note

Ensure sealing flange lies flat on assembly device.

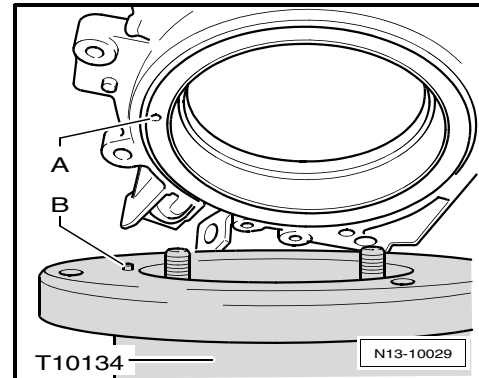

- Push sealing flange and support ring for sealing lip -B- against surface of assembly tool -T10134- whilst tightening the three knurled screws -A- so that locating pin cannot slide out of sender wheel hole.

i Note

When installing sealing flange, ensure that sender wheel remains fixed in assembly device.

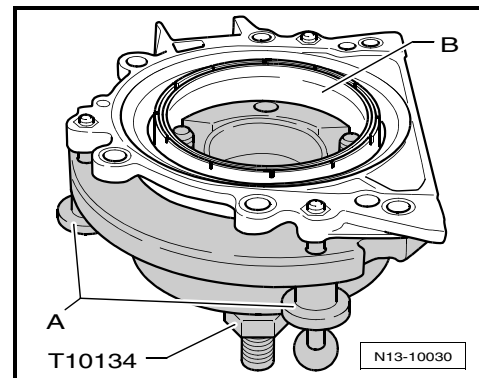

2.4.4 B - Attaching assembling tool -T10134- with sealing flange to crankshaft flange

- Crankshaft flange must be free of oil and grease.
- Engine positioned at TDC No. 1 cylinder
- Screw hexagon nut -B- to end of threaded spindle.
- Press threaded spindle of assembly tool -T10134- in -direction of arrow-, until hexagon nut -B- lies against assembly hub -A-.
- Align flat side of assembly housing on sump side of crankcase sealing surface.

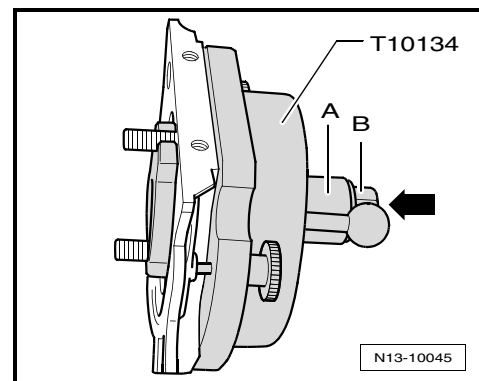

- Secure assembly tool -T10134- to crankshaft flange using hexagon socket head bolts -A-.

i Note

Screw hexagon socket head bolts -A- into crankshaft flange (approx. 5 full turns).

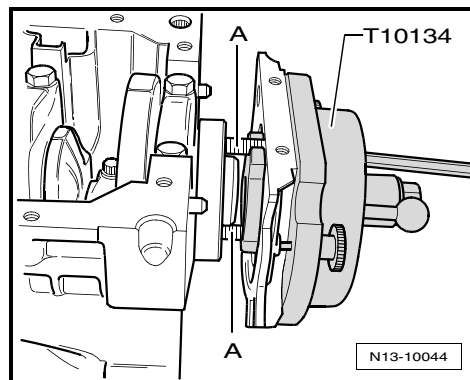

- Screw in two M7 x 35 mm bolts -A- to guide sealing flange into cylinder block.

2.4.5 C - Bolting assembly tool -T10134- onto crankshaft flange

- Push assembly hub -C- by hand in -direction of arrow- until sealing lip support ring -B- contacts crankshaft -A-.
- Push guide pin for diesel engines (black knob) -D- into hole in crankshaft. Then the sender wheel is in its final installation position.

i Note

The guide pin for petrol engines (red knob) -F- must not be inserted in threaded hole of crankshaft.

- Hand-tighten both hexagon socket head bolts of assembly tool.
- Screw hexagon nut -E- onto threaded spindle by hand until it is in contact with assembly housing -C-.

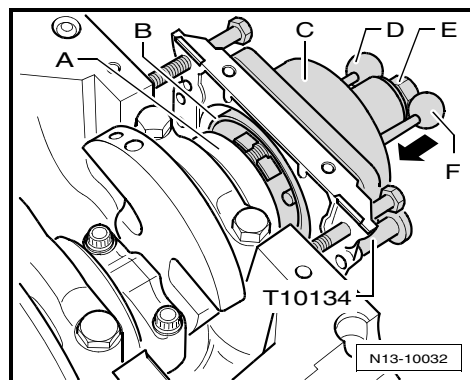
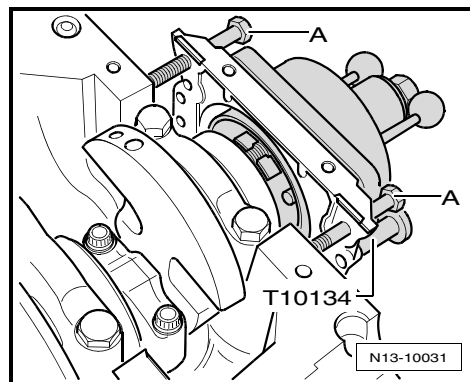

2.4.6 D - Pressing sender wheel onto crankshaft flange using assembly tool -T10134-

- Tighten hexagon nut of assembly tool -T10134- to 35 Nm using torque wrench -V.A.G 1331- and insert -V.A.G 1332/11-.

i Note

After hexagon nut is tightened to 35 Nm, a small air gap must be present between cylinder block and sealing flange.

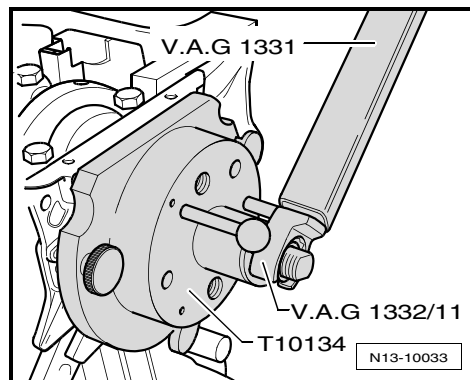



2.4.7 E - Checking sender wheel installation position on crankshaft

- Screw hexagon nut -E- to end of threaded spindle.
- Remove the two bolts -A- from cylinder block.
- Screw the three knurled screws -B- out of sealing flange.
- Remove assembly tool -T10134-.
- Remove sealing lip support ring.

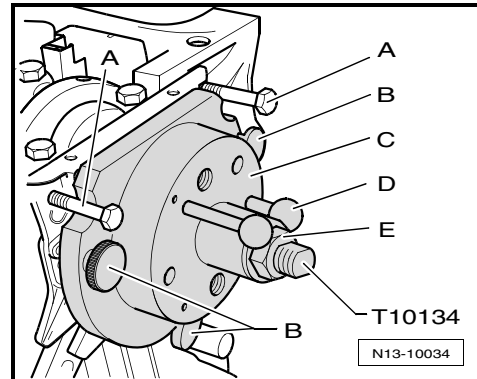

- The sender wheel is in the correct installation position on the crankshaft if a gap -a- = 0.5 mm exists between crankshaft flange -A- and sender wheel -B-.

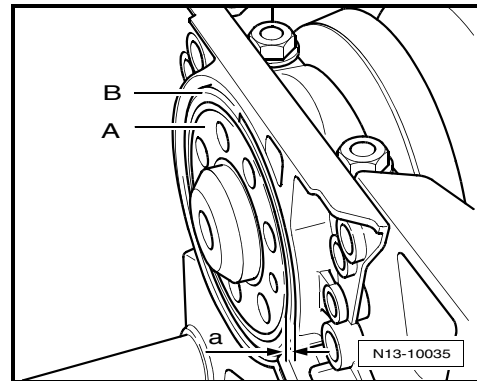

- Set vernier gauge on crankshaft flange.
- Measure distance -a- between crankshaft flange and sender wheel.

If measurement -a- is too small:

- Re-press sender wheel ⇒ [page 97](#).

If dimension -a- is attained:

- Tighten new securing bolts for sealing flange to 15 Nm using alternate and diagonal sequence.

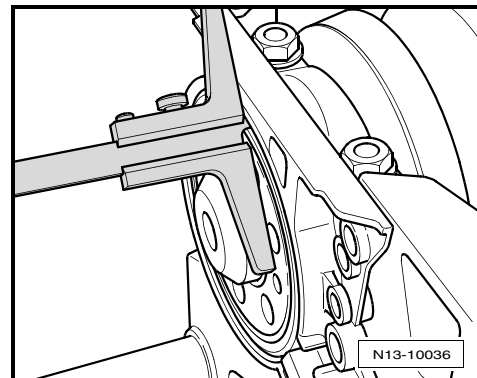

- Install engine speed sender -G28- -arrow- and tighten securing bolt to 5 Nm.
- Install sump ⇒ [page 149](#).
- Install intermediate plate.
- Install flywheel using new bolts. Tighten securing bolts to 60 Nm + 1/4 turn (90 °).

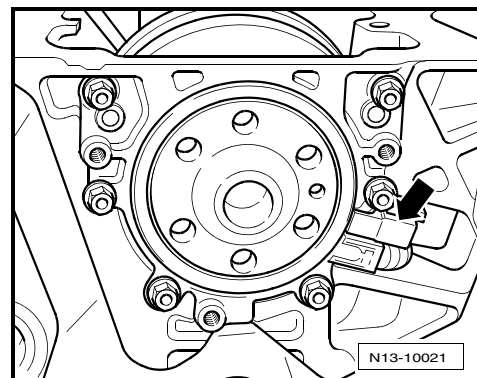



2.4.8 F - Pressing sender wheel

- Secure assembly tool -T10134- to crankshaft flange using hexagon socket head bolts -A-.
- Hand tighten both hexagon socket head bolts -A-.
- Push assembly tool -T10134- by hand to sealing flange.

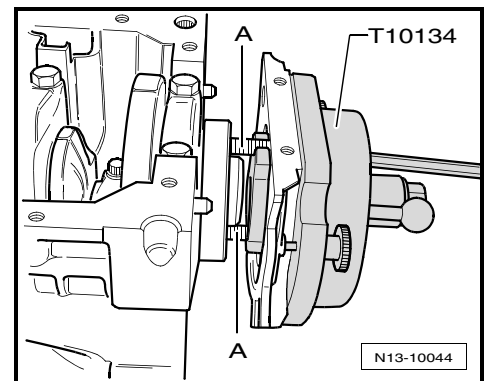

- Screw hexagon nut -E- onto threaded spindle by hand until it is in contact with assembly housing -C-.

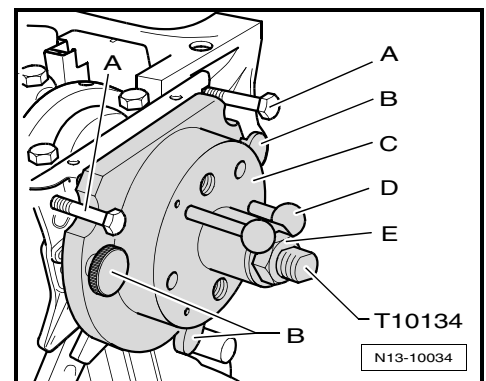

- Tighten hexagon nut of assembly tool -T10134- to 40 Nm using torque wrench -V.A.G 1331- and insert -V.A.G 1332/11-.
- Check installation position of sender wheel on crankshaft again ⇒ [page 96](#).

If dimension -a- is too small again:

- Tighten hexagon nut for assembly tool -T10134- to 45 Nm.
- Check installation position of sender wheel on crankshaft again ⇒ [page 96](#).

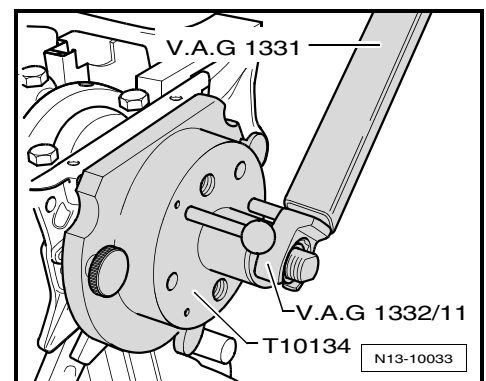

2.5 Removing and installing engine speed sender -G28-

Special tools and workshop equipment required

- ◆ Torque wrench (5...50 Nm) -V.A.G 1331-

Removing ⇒ [page 97](#).

Installing ⇒ [page 98](#).

2.5.1 Removing

- Clamp off coolant hoses at oil cooler using hose clamp and pull off hoses.
- Remove oil filter bracket ⇒ [page 152](#), Assembly overview - oil filter bracket and oil cooler

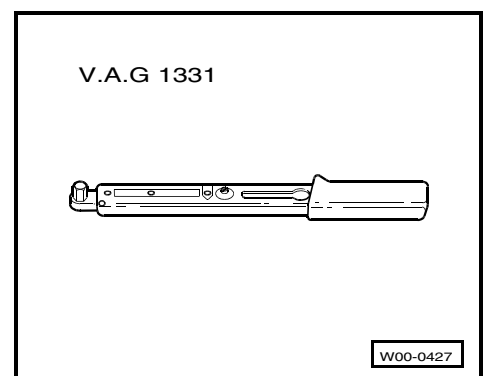



- Pull 3-pin connector off engine speed sender -G28-.
- Loosen securing bolt -arrow- in crankcase through opening using a commercially available ball-ended socket and pull out engine speed sender -G28-.

2.5.2 Installing

Installation is carried out in the reverse order. When installing, note the following:

- Tighten securing bolts for engine speed sender -G28- to 5 Nm.

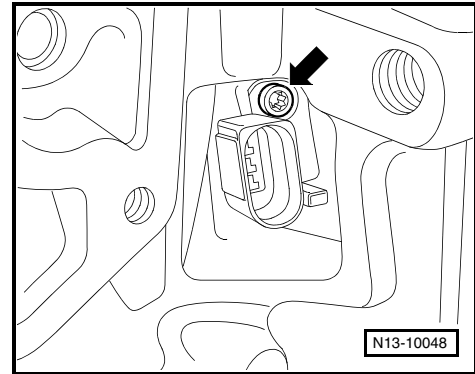

3 Removing and installing crankshaft



Note

- ◆ *Before carrying out repair work, secure engine on engine and gearbox support -VAS 6095- using universal mounting -VAS 6095/1-.*
- ◆ *Finding metal shavings or a large quantity of small metal particles during engine repair could indicate that the crankshaft bearings or conrod bearings are damaged. To prevent this from causing further damage, perform the following repairs:*
 - ◆ *Thoroughly clean oil channels.*
 - ◆ *Renew oil spray jets.*
 - ◆ *Renew oil cooler.*
 - ◆ *Renew oil filter element*

Assembly overview - crankshaft ⇒ [page 99](#).

Crankshaft dimensions ⇒ [page 99](#).

Pulling needle bearing out of and driving into crankshaft (when installed) ⇒ [page 100](#).



3.1 Assembly overview - crankshaft

1 - Bearing shells 1, 2, 4 and 5

- For bearing cap without oil groove
- For cylinder block with oil groove
- Do not interchange used bearing shells (mark).

2 - 65 Nm + 1/4 turn further (90°).

- Renew.
- To measure radial clearance, tighten to 65 Nm but not further.

3 - Bearing cap

- Bearing cap 1: Belt pulley end
- Bearing cap 3 with recesses for thrust washers
- Bearing shell retaining lugs in cylinder block and bearing caps must align.

4 - Thrust washer

- For bearing cap 3
- Pay attention to retainer

5 - Needle bearing

- Not installed on all engines.

- Extracting and driving in ⇒ [page 100](#)

6 - Crankshaft

- Axial clearance new: 0.07...0.17 mm wear limit: 0.37 mm.
- Check radial clearance with Plastigage new: 0.03...0.08 mm wear limit: 0.17 mm.
- Do not rotate crankshaft when checking radial clearance.
- Crankshaft dimensions ⇒ [page 99](#).

7 - Thrust washer

- For cylinder block, bearing 3.

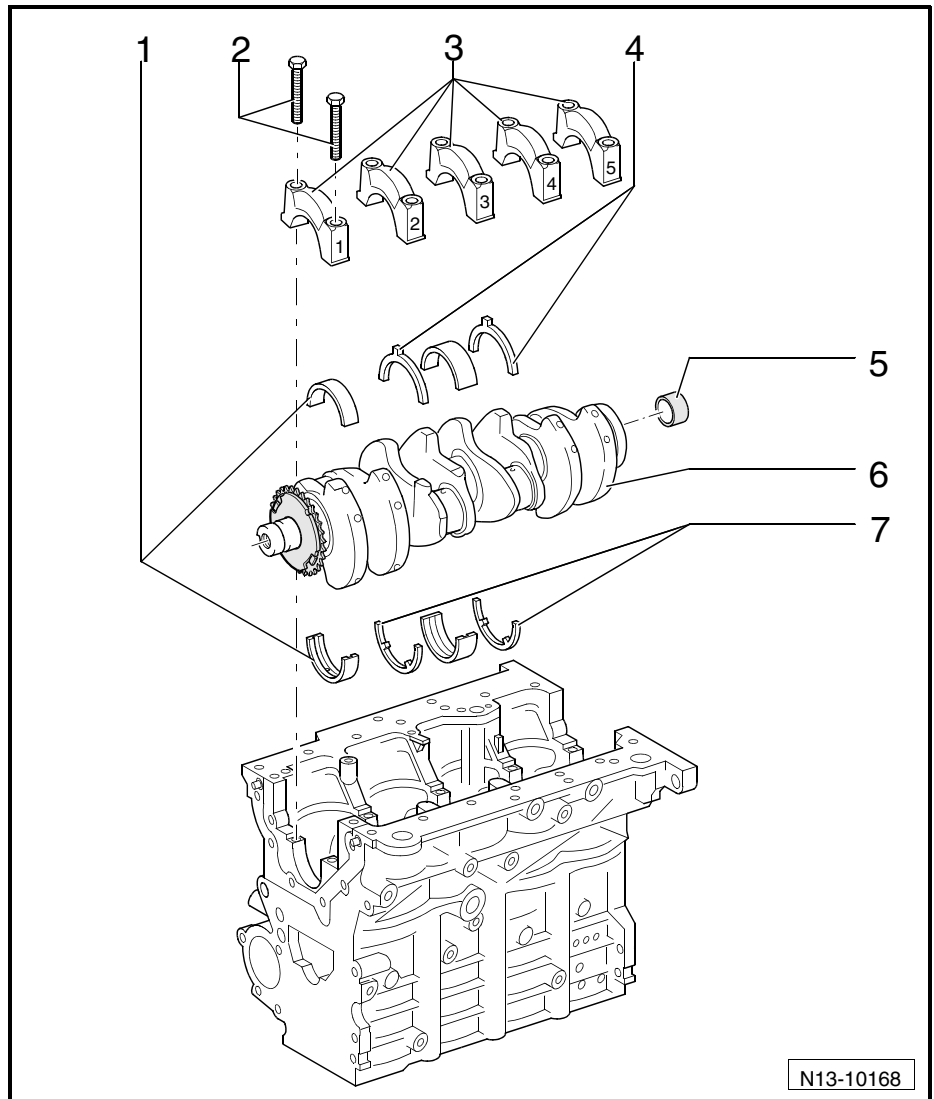

N13-10168

3.2 Crankshaft dimensions

(Dimensions in mm)

Honing dimension	Crankshaft main journal Ø	Conrod journal Ø
Basic dimension	-0,022	-0,022
	54,00	50,90
	-0,042	-0,042



3.3 Pulling needle bearing out of and driving into crankshaft (when installed)

i *Note*

The needle bearing is not fitted on all engines.

Special tools and workshop equipment required

- ◆ Puller -T10055-
- ◆ With adapter -T10055/3-

- ◆ Centring mandrel -3176-
- ◆ or drift -VW 207 C-
- ◆ Puller, e.g. Kukko -21/2-

Pulling out ⇒ [page 100](#).

Driving in ⇒ [page 100](#).

3.3.1 Pulling out

- Extract with commercially available puller, e.g. Kukko -21/2- -arrow-, adapter -T10055/3- and puller -T10055-.

3.3.2 Driving in

i *Note*

The lettering on the needle bearing must be visible when installed.

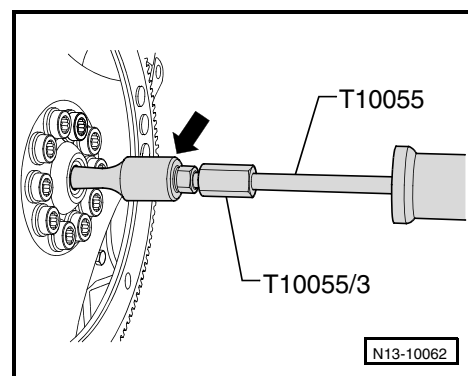
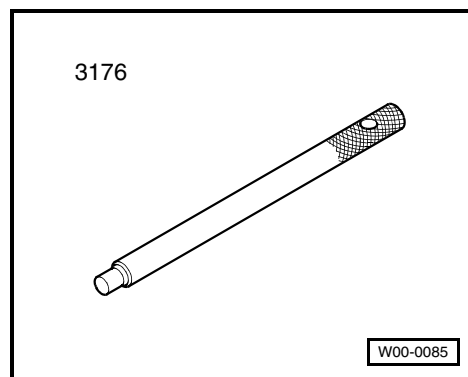
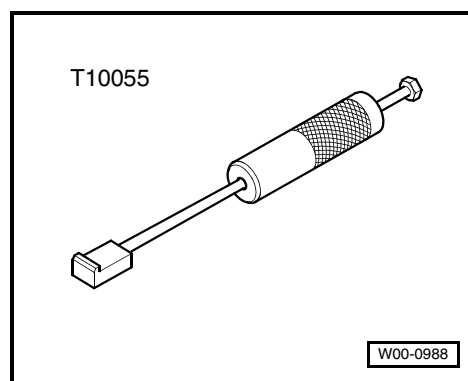



- Drive in with drift -VW 207 C- or centring mandrel -3176-.

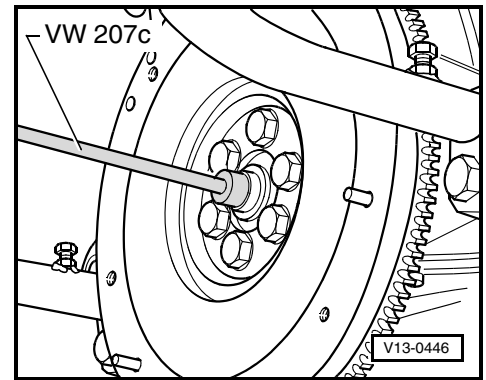

Installation depth: dimension -a- = 2 mm.

4 Dismantling and assembling pistons and conrods

Note

Before carrying out repair work, secure engine on engine and gearbox support -VAS 6095- using universal mounting -VAS 6095/1-.

Assembly overview - pistons and conrods ⇒ [page 102](#).

Separating new conrods ⇒ [page 105](#).

Bearing shells - installation position ⇒ [page 106](#).

Checking piston projection at TDC ⇒ [page 106](#).

Piston and cylinder dimensions ⇒ [page 107](#).

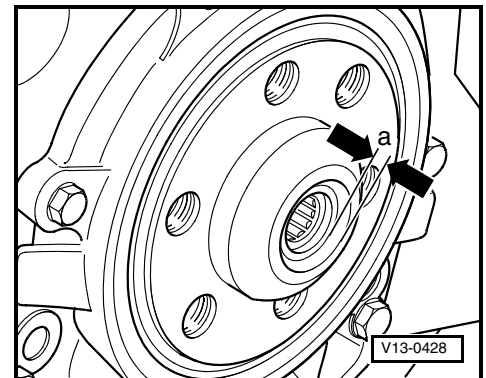



4.1 Assembly overview - pistons and conrods

1 - Piston rings

- Offset gaps by 120°.
- Use piston ring pliers to remove and install.
- "TOP" faces towards piston crown.
- Checking ring gap ⇒ Fig. on page 103.
- Checking ring-to-groove clearance ⇒ Fig. on page 103.

2 - Piston

- Mark installation position and cylinder number.
- Installation position and allocation of piston to cylinder ⇒ Fig. on page 105.
- Arrow on piston crown points to belt pulley end.
- Install using piston ring clamp.
- If piston skirt is cracked, renew piston
- Checking piston projection at TDC ⇒ page 106

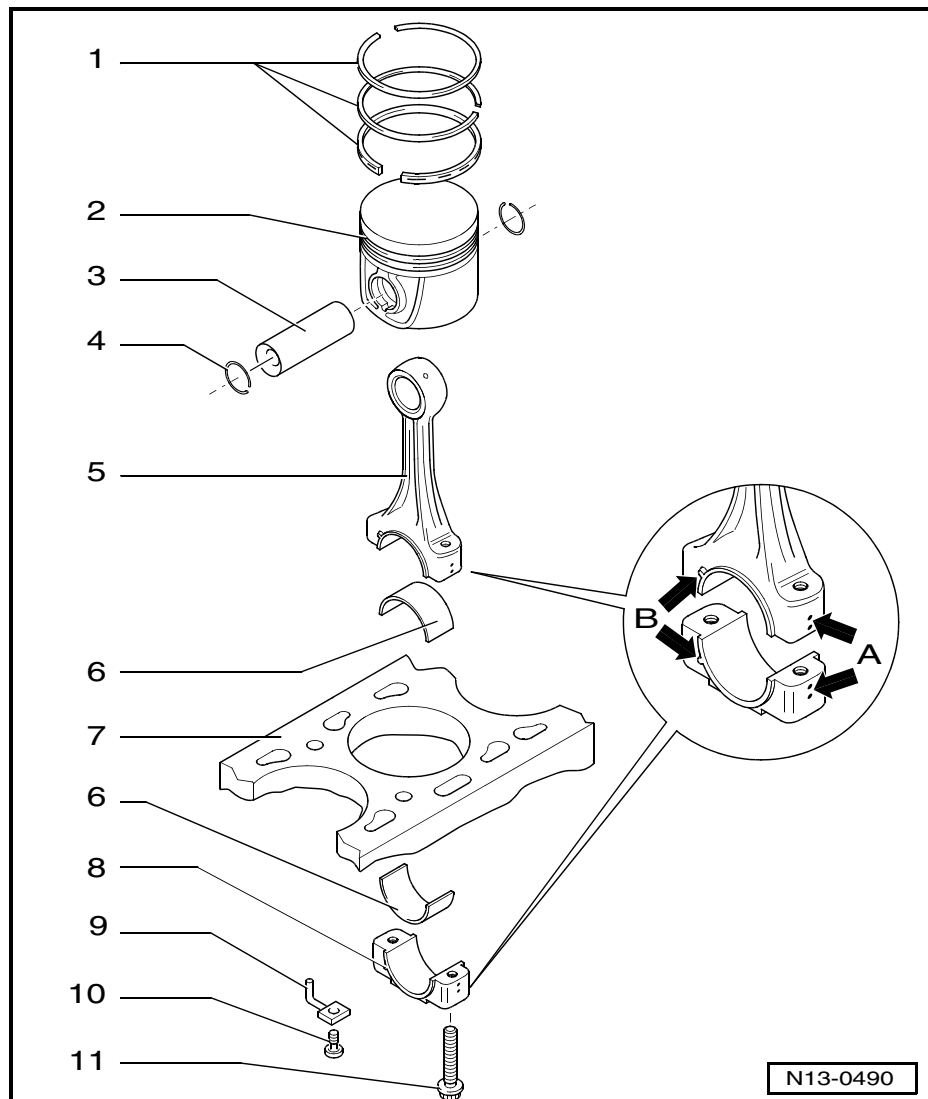

N13-0490

3 - Piston pin

- If difficult to remove, heat piston to 60 °C.
- Remove and install using drift -VW 222 a-.

4 - Circlip

5 - Conrod

- Mark cylinder number -A-.
- Installation position: Marking -B- faces towards pulley end
- With industrially cracked conrod cap.
- Separating new conrod ⇒ page 105.

6 - Bearing shell

- Note installation position ⇒ page 106
- Do not interchange used bearing shells.
- Insert bearing shells centrally
- Check for secure seating
- Axial clearance wear limit: 0.37 mm.
- Checking radial clearance with Plastigage: Wear limit: 0.08 mm. Do not rotate crankshaft when checking radial clearance.



7 - Cylinder block

- Checking cylinder bores ⇒ Fig. on page 105.
- Piston and cylinder dimensions ⇒ page 107.

8 - Conrod bearing cap

- Note installation position.
- Due to the cracking method used to separate the bearing cap from the conrod in manufacture, the caps only fit in one position and only on the appropriate conrod.
- Separating new conrod ⇒ page 105.

9 - Oil spray jet

- For piston cooling.

10 - 25 Nm

- Insert without sealant.

11 - Conrod bolt, 30 Nm + 1/4 turn further (90 °).

- Renew.
- Oil threads and contact surface
- Use old bolts to measure radial clearance.

Checking piston ring gap

Special tools and workshop equipment required

- ◆ Feeler gauges

Test procedure

- Push piston ring squarely from above down to approx. 15 mm from bottom end of cylinder.

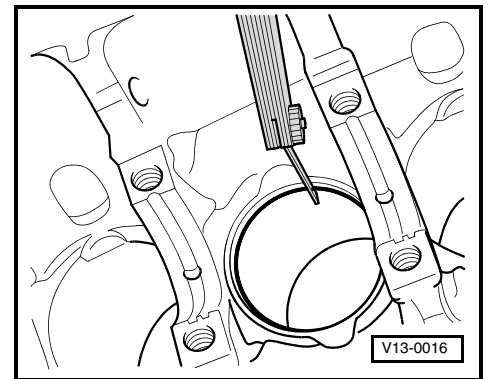

Piston ring		Ring gap	
		New	Wear limit
1. compression ring	mm	0.20...0.40	1.00
2. compression ring	mm	0.20...0.40	1.00
Oil scraper ring	mm	0.25...0.50	1.00

Checking ring-to-groove clearance

Special tools and workshop equipment required

- ◆ Feeler gauges

Test procedure

- Clean ring groove before checking.

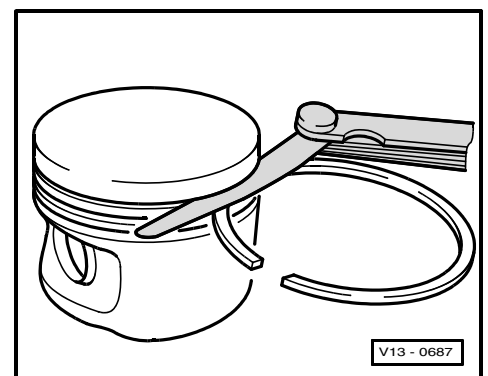

Piston ring		Clearance	
		New	Wear limit
1. compression ring	mm	0.06...0.09	0.25
2. compression ring	mm	0.05...0.08	0.25
Oil scraper ring	mm	0.03...0.06	0.15





Checking cylinder bores

Special tools and workshop equipment required

- ◆ Internal dial test indicator 50...100 mm

Test procedure

- Take measurements at 3 positions in both transverse -A- and longitudinal -B- directions, as illustrated.

Difference between actual and nominal diameter max. 0.10 mm.



Note

Cylinder bores must not be measured when cylinder block is mounted on a repair stand with engine and gearbox support -VAS 6095-, as measurements may then be incorrect.

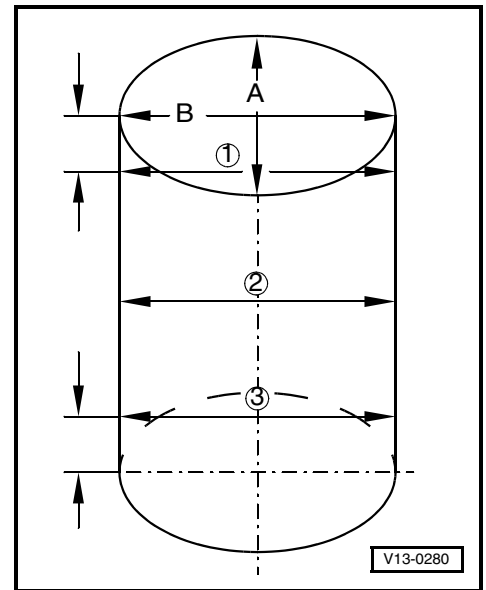

Piston installation position and allocation of piston to cylinder

Arrow on piston crown -arrows- points in direction of cylinder 1.

4.2 Separating new conrods

On new conrods it is possible that the breaking point is not fully separated. Proceed as follows, when the conrod bearing cap cannot be removed by hand:

- Mark cylinder allocation of conrod
- Lightly clamp the conrod in a vice using aluminium vice clamps, as shown in the illustration.



Note

- ◆ *To prevent damage to the conrod, only clamp conrod in lightly.*
- ◆ *Conrod is clamped below the dashed line.*
- Unscrew the two bolts -arrows- approx. 5 turns.

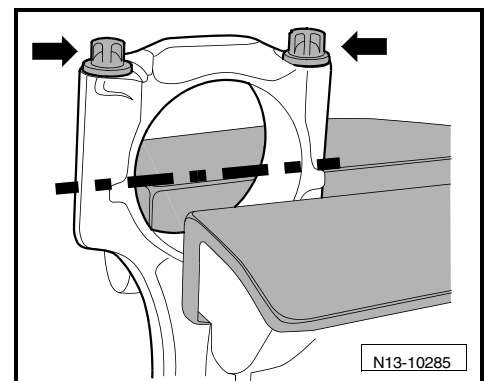
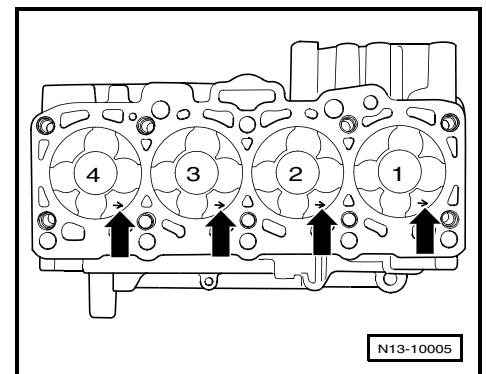

- Using a plastic hammer, carefully knock against conrod bearing cap in -direction of arrow- until it is loose.

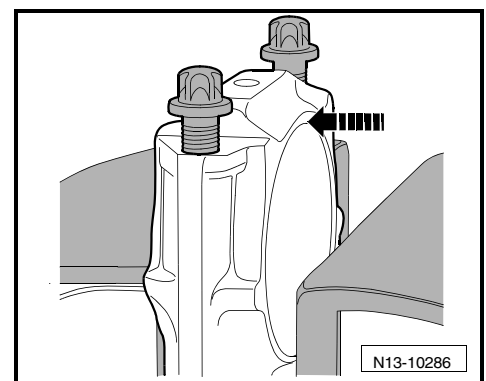



4.3 Bearing shells - installation position

Bearing shell -1- with oil hole -arrow- for conrod.

Bearing shell -2- without oil hole for conrod bearing cap.

- Position bearing shells in centre of conrod and conrod bearing cap when fitting.

Dimension -a- must be identical on both sides.

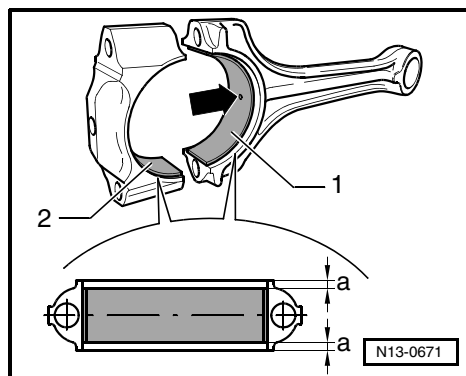

4.4 Checking piston projection at TDC

Special tools and workshop equipment required

- ◆ Measuring bridge -VW 382/7-

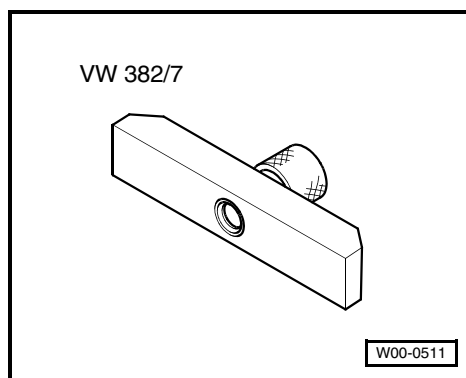

- ◆ End dimension plate -VW 385/17-

Not illustrated:

- ◆ Dial gauge

Test procedure

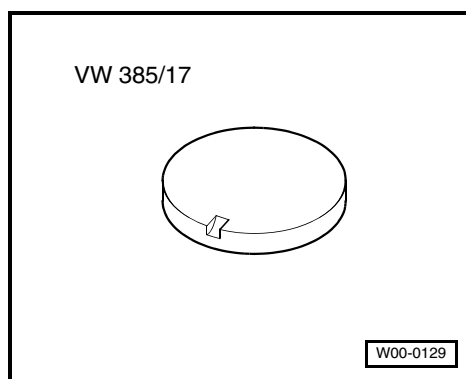

Piston projection at TDC must be measured when installing new pistons or a short engine. Install the appropriate cylinder head gasket depending upon piston projection, according to following table:

i Note

- ◆ Turn engine clockwise to measure piston projection at TDC.
- ◆ If different values are determined during the projection measurement, use the largest dimension for selection of the gasket.

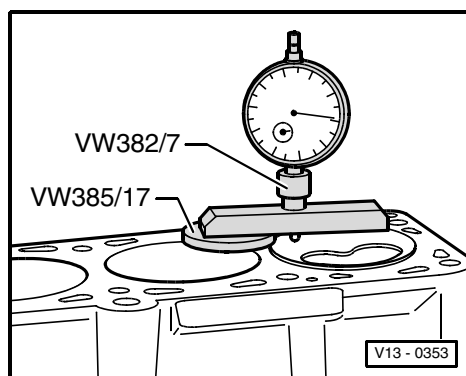

Piston projection	Identification Holes/notches
0.91 mm ... 1.00 mm	1
1.01 mm ... 1.10 mm.	2
1.11 mm ... 1.20 mm.	3



Cylinder head gasket identification

- ◆ Part number = arrow 1
- ◆ Holes = arrow 2
- ◆ Production control code = arrow 3 (disregard)

i **Note**

- ◆ *Different thicknesses of cylinder head gasket are fitted depending on the piston projection. When installing oil seal, observe identical markings.*
- ◆ *Piston projection at TDC must be determined when installing new pistons or a short engine ⇒ [page 106](#).*

4.5 Piston and cylinder dimensions

Honing dimension		Piston \varnothing	Cylinder bore \varnothing
Basic dimension	mm	80,96	81,01

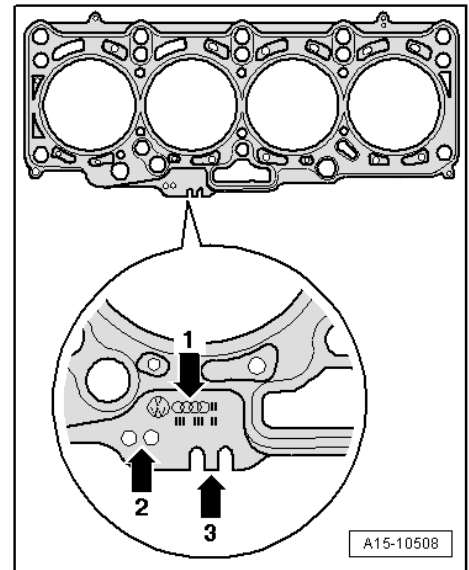



15 – Cylinder head, valve gear

1 Cylinder head

 **Note**

- ♦ *The plastic protectors fitted to protect the open valves must be removed only immediately before the cylinder head is fitted.*
- ♦ *If the cylinder head is replaced, all the coolant in the system must also be renewed.*

Observe safety precautions ⇒ [page 208](#).

Observe rules for cleanliness ⇒ [page 208](#).

Assembly overview - cylinder head ⇒ [page 109](#).

Removing and installing Hall sender -G40- ⇒ [page 110](#).

Assembly overview - cylinder head cover ⇒ [page 113](#).

Removing and installing cylinder head cover ⇒ [page 114](#).

Removing, installing and tensioning toothed belts
⇒ [page 117](#).

Removing and installing cylinder head ⇒ [page 123](#).

Removing and installing vacuum pump ⇒ [page 130](#).

Checking compression ⇒ [page 131](#).

1.1 Assembly overview - cylinder head

- 1 - **Cylinder head**
 - Checking for distortion ⇒ Fig. on page 110
 - Removing and installing ⇒ page 123.
 - After renewing, renew entire coolant.
- 2 - **Washer**
 - For cylinder head bolt
- 3 - **Cylinder head bolt**
 - Renew.
 - Adhere to sequence when loosening and tightening ⇒ page 123, removing and installing cylinder head
 - Before installing, place washers in cylinder head ⇒ item 2
- 4 - **25 Nm**
- 5 - **Lifting eye**
- 6 - **Gasket**
 - Renew.
- 7 - **Vacuum pump**
 - Removing and installing ⇒ page 130.
- 8 - **10 Nm**
- 9 - **Coolant hose connection**
- 10 - **10 Nm**
- 11 - **Gasket**
 - Renew.
- 12 - **25 Nm**
- 13 - **Lifting eye**
- 14 - **Cylinder head gasket**
 - Renew.
 - Note marking ⇒ Fig. on page 110
 - After renewing, renew entire coolant.
- 15 - **Hall sender -G40-**
 - For camshaft position
 - Checking ⇒ page 245.
 - Removing and installing ⇒ page 110.
- 16 - **10 Nm**

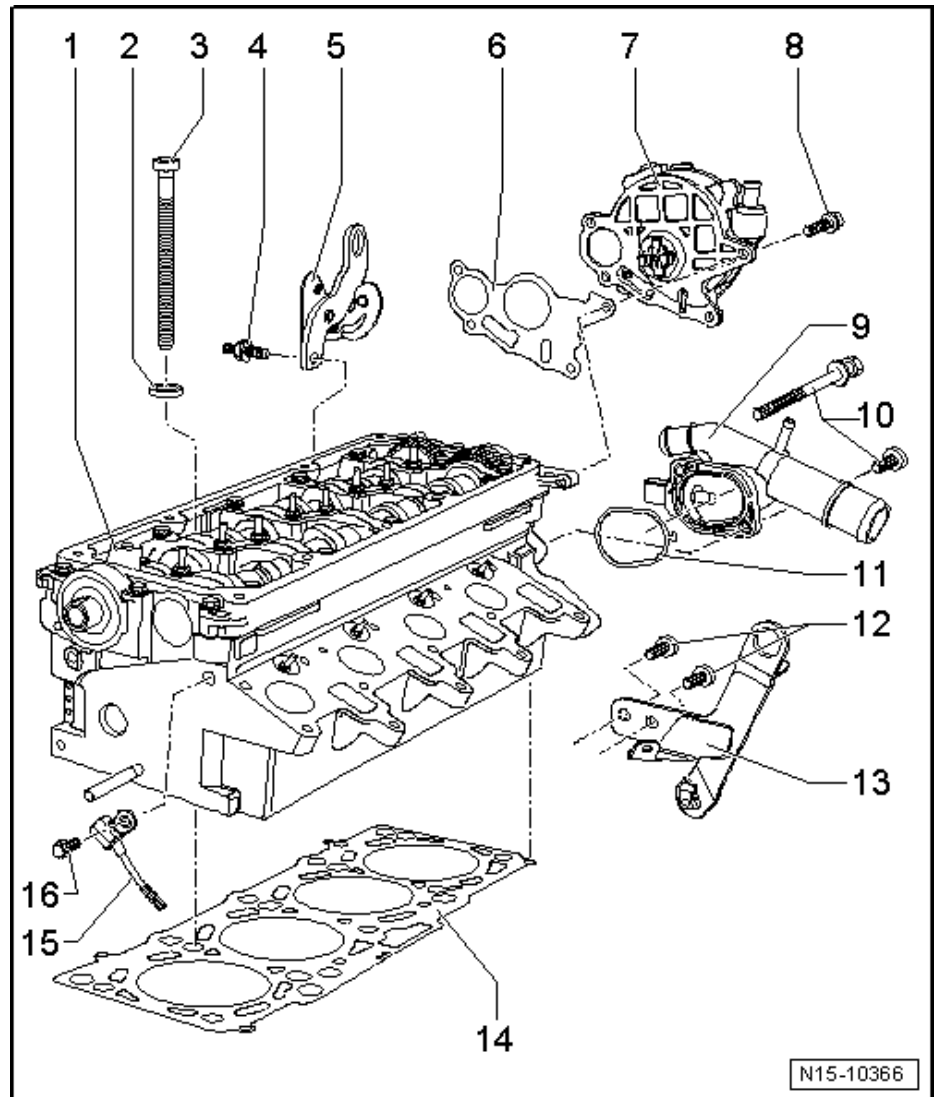



Checking cylinder head for distortion

Special tools and workshop equipment required

- ◆ Straightedge 500 mm -VAS 6075-
- ◆ Feeler gauges

Max. permissible distortion: 0.1 mm.

Note

The cylinder heads of diesel engines must not be machined.

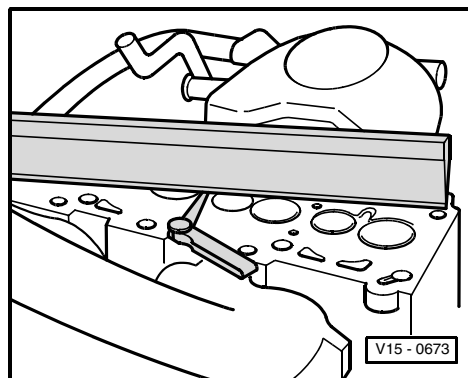

Cylinder head gasket identification

- ◆ Part number = arrow 1
- ◆ Holes = arrow 2
- ◆ Production control code = arrow 3 (disregard)

Note

- ◆ *Different thicknesses of cylinder head gasket are fitted depending on the piston projection. When installing oil seal, observe identical markings.*
- ◆ *Piston projection at TDC must be determined when installing new pistons or a short engine ⇒ [page 106](#).*

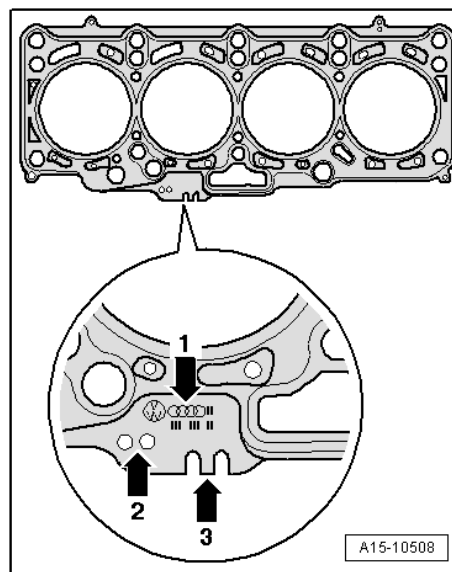

1.2 Removing and installing Hall sender -G40-

Removing

- Remove engine cover.
- Remove poly V-belt ⇒ [page 76](#).
- Open clips -arrows- and remove toothed belt guard.
- Remove vibration damper ⇒ [item 29 on page 81](#).
- Position crankshaft at TDC and lock crankshaft toothed belt pulley with crankshaft stop -T10050-. To do this, push crankshaft stop into teeth of belt pulley from face side. Camshaft toothed segment must be at "12 o'clock".

Note

The markings on the crankshaft toothed belt pulley -2- and the crankshaft stop -T10050- -1- must align. At the same time, the pin of the crankshaft stop -T10050- must engage in the drilling in the sealing flange.

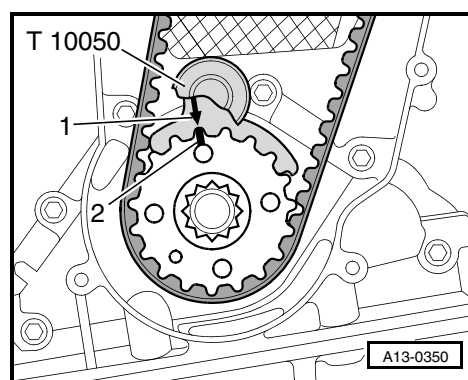

- Loosen securing bolts -1- for camshaft toothed belt pulley.

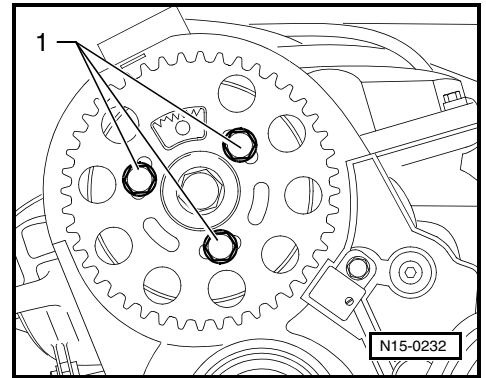

- Loosen securing bolt of coolant pipe -1- and then securing bolts of toothed belt pulley for high-pressure pump -2-.
- Loosen tensioning roller securing nut -1-.

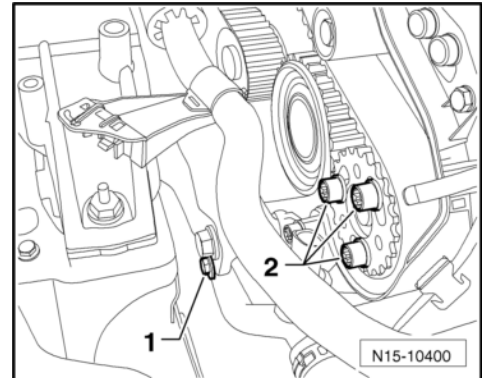

- Turn the eccentric adjuster with the special wrench -T10264- anti-clockwise -arrow- until the tensioning roller can be secured with the locking pin -T10265-.

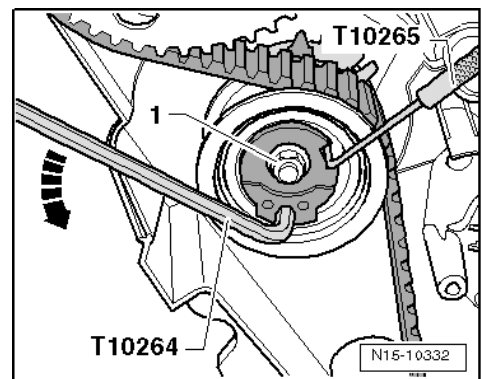

- Now turn eccentric of tensioning roller clockwise -arrow- to stop and tighten securing nut -1- hand-tight.
- Remove toothed belt from idler roller and high-pressure pump.

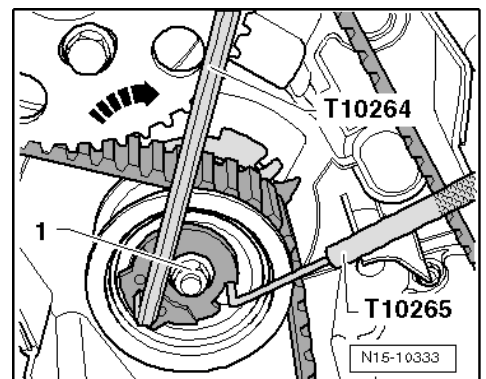



- Separate connector for Hall sender -G40- -arrow-.
- Detach plug from its retainer.

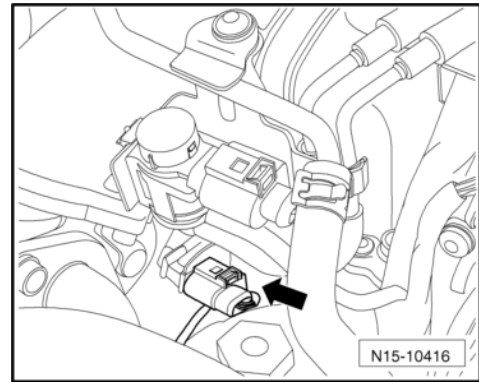

- Unscrew Hall sender -G40- -arrow-.

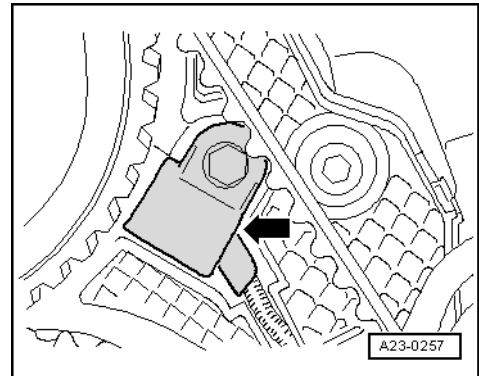

- Remove webs and repair aperture cover -arrows- with a screwdriver.
- Remove Hall sender -G40- from cylinder head and guide its plug through repair aperture in toothed belt guard.

Installing

Installation is carried out in the reverse sequence of removal. In the process, note the following:

- ◆ Seal repair aperture in toothed belt guard with rubber plugs as specified in ⇒ ETKA (electronic parts catalogue).
- Fit toothed belt and adjust valve timing ⇒ [page 117](#).

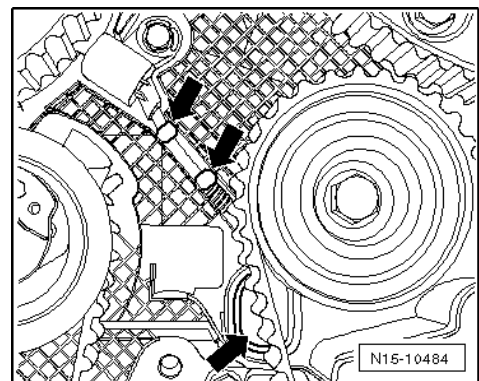

1.3 Assembly overview - cylinder head cover

- 1 - 5 Nm
- 2 - High-pressure accumulator (rail)
 - With injector pipes
 - Do not attempt to bend injector pipes to a different shape
- 3 - 22 Nm
- 4 - Injector (piezo injectors)
 - Removing and installing ⇒ [page 216](#).
- 5 - 5 Nm
- 6 - Injector cover
- 7 - Sleeve
 - For securing high-pressure accumulator (common rail)
 - Renew if damaged.
- 8 - 10 Nm
- 9 - Clamping piece
 - Note installation position ⇒ [Fig. on page 215](#)
- 10 - Cable guide
- 11 - Cylinder head cover
 - Removing and installing ⇒ [page 114](#).
- 12 - Gasket
 - Renew if damaged or leaking.
- 13 - 10 Nm
 - Observe tightening sequence ⇒ [page 114](#).
- 14 - Cover
- 15 - Heat shield

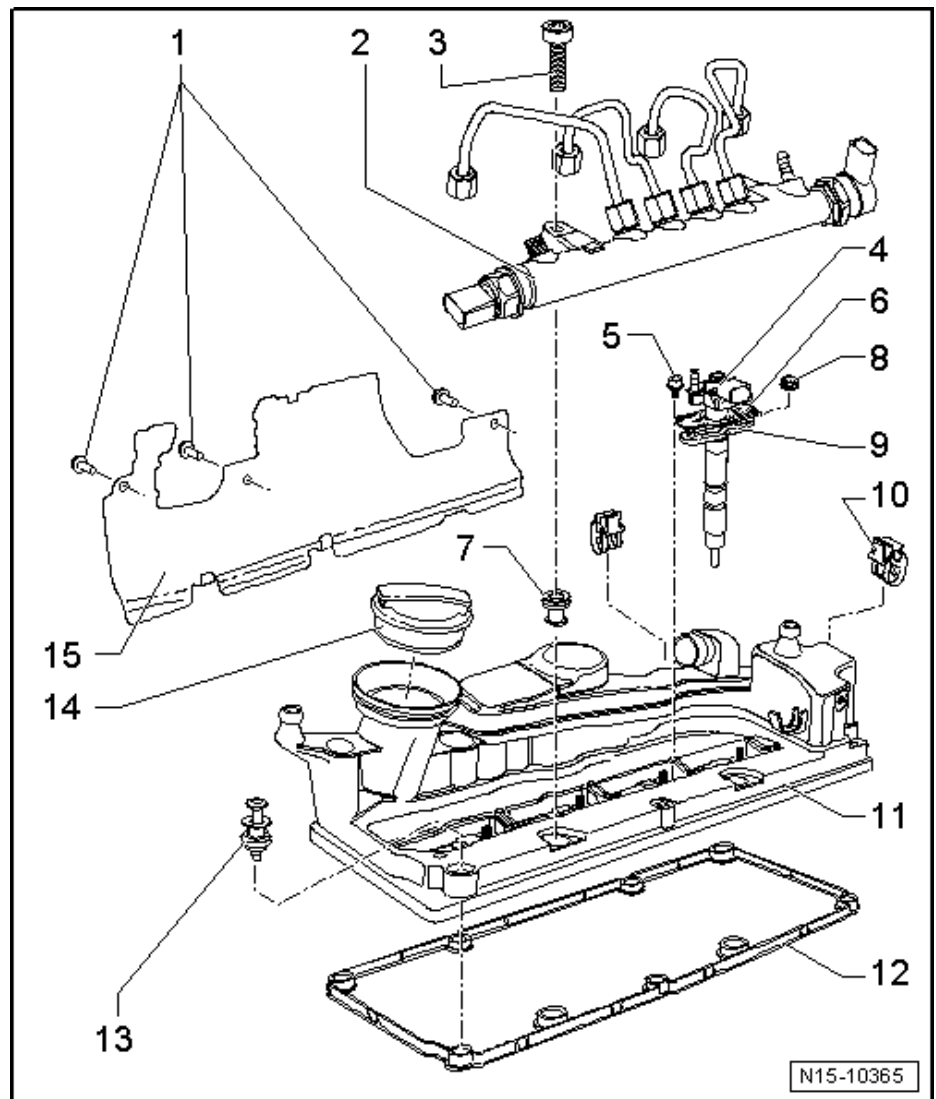



1.4 Removing and installing cylinder head cover

Special tools and workshop equipment required

- ◆ Torque wrench -V.A.G 1331-

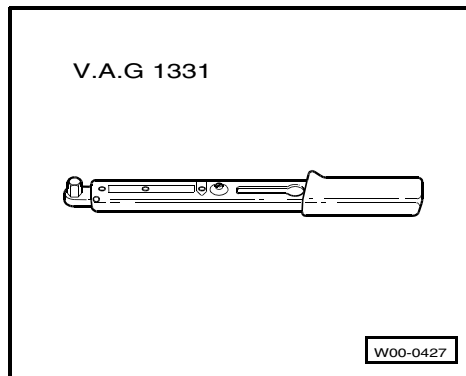

- ◆ Pliers -3314-

Removing

- Remove engine cover.
- Remove noise insulation from injectors.

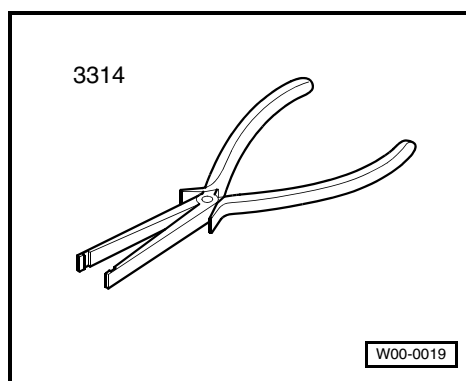

- Pull connectors off injectors -A-, exhaust gas pressure sensor 1 -G450- -B- and common rail pressure sensor -C-.
- Unscrew securing bolts of coolant line -arrows- from intake manifold and set down coolant line in front of intake manifold.

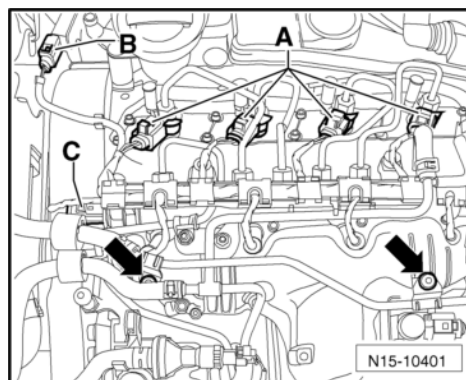

⚠ Caution!

Ensure that no cable connections are damaged when pulling off connectors. Otherwise the complete wiring harness must be renewed. Do not compress the pliers -3314- to firmly to separate the connectors, otherwise the support sleeve may be damaged.

- Position pliers -3314- with groove -arrow A- on support sleeve shoulder -arrow B- and pull plugs off glow pin plugs.

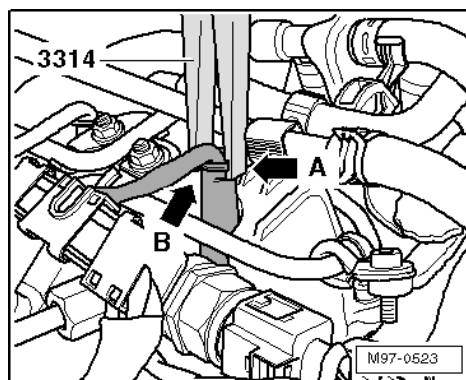

- Carefully pull connector off glow pin plug in direction of -arrow-.

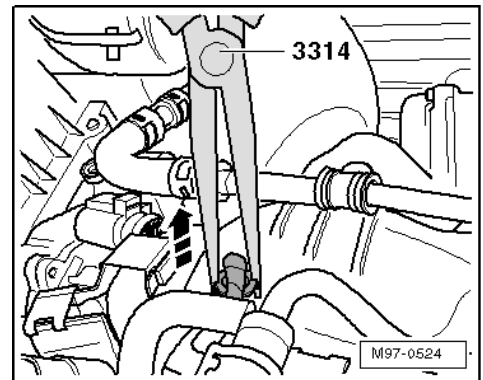

- Unscrew securing nut of fuel return line from intake manifold, open clamp -arrow- and pull line off fuel rail.

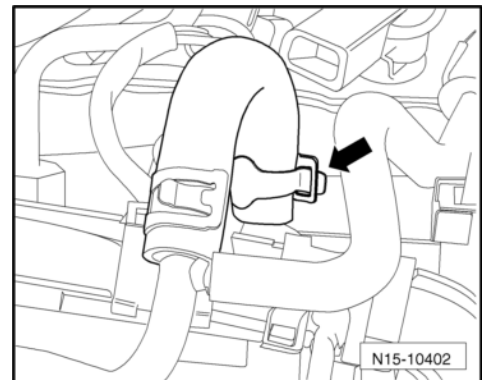

- Pull fuel return line connections off injectors. To do this, push down connection at tabs and pull up centre piece to release.

i Note

Adhere strictly to rules of cleanliness. No dirt must be allowed to get into the disconnected fuel return lines or the open connections on the injectors.

- Remove entire fuel return line and set it down in front of intake manifold.
- Pull connector of position sender for charge pressure positioner -G581- -arrow- off turbocharger and guide wiring out of retainers.

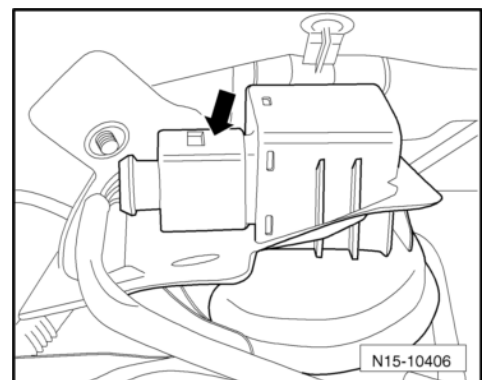
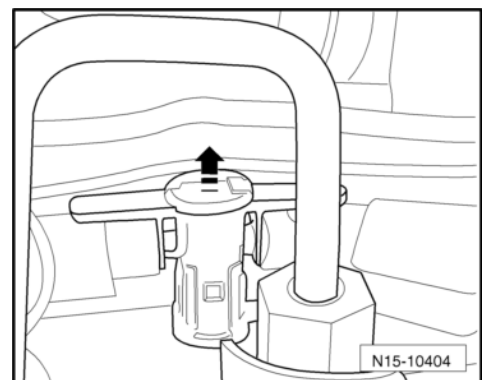



- Pull connector off fuel pressure regulating valve -N276-
-arrow-.
- Remove wiring harness from rail and lay to one side.
- Pull vacuum line off cylinder head cover. Remove remain-
ing vacuum hoses from bracket on cylinder head cover.
- Remove upper toothed belt cover.
- Remove breather line between cylinder head cover and in-
take hose. Press quick-release fasteners to do this.
- Remove high-pressure line between high-pressure pump
and common rail.
- Remove high-pressure lines between common rail and in-
jectors.
- Unscrew bolts -arrows- and remove common rail.
- Remove injectors ⇒ [page 216](#).
- Remove securing bolts for cylinder head cover and take off
cylinder head cover.

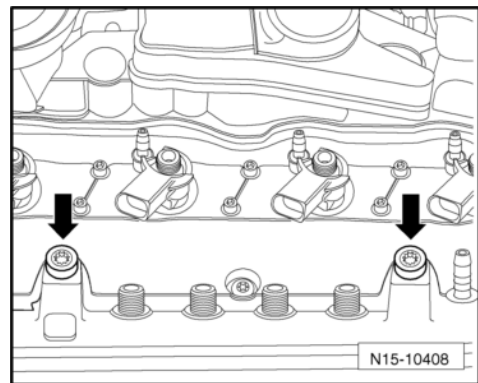
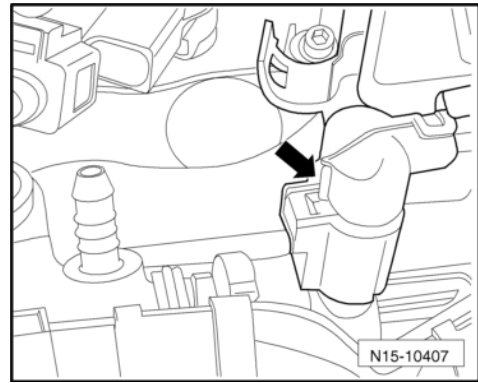

Installing

Installation is carried out in the reverse sequence of removal.
In the process, note the following:

i Note

Renew seal for bolts if damaged.

- Screw on cylinder head cover hand-tight in the sequence -
1 to 7.-
- Tighten bolts to 10 Nm in the sequence 1 to 7.
- Ensure that cylinder head cover is correctly clipped to
toothed belt guard.

i Note

*For clarity the camshaft pulleys/chain sprockets are not
shown.*

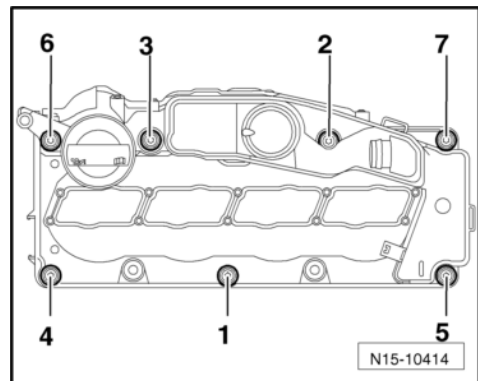

- To do this, press toothed belt guard (using a screwdriver if
necessary) against cylinder head cover in area of clips -ar-
rows- until clips engage audibly together.
- Check whether clearance between hub and toothed belt
cover is sufficient.
- Install high-pressure pipes ⇒ [page 219](#).

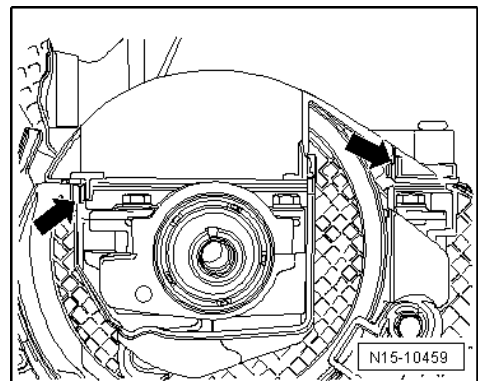



1.5 Removing, installing and tensioning toothed belt

Special tools and workshop equipment required

- ◆ Locking pin -3359-
- ◆ Crankshaft stop -T10050-
- ◆ Counterhold -T10172-
- ◆ Special wrench, long reach -T10264-
- ◆ Locking tool -T10265-

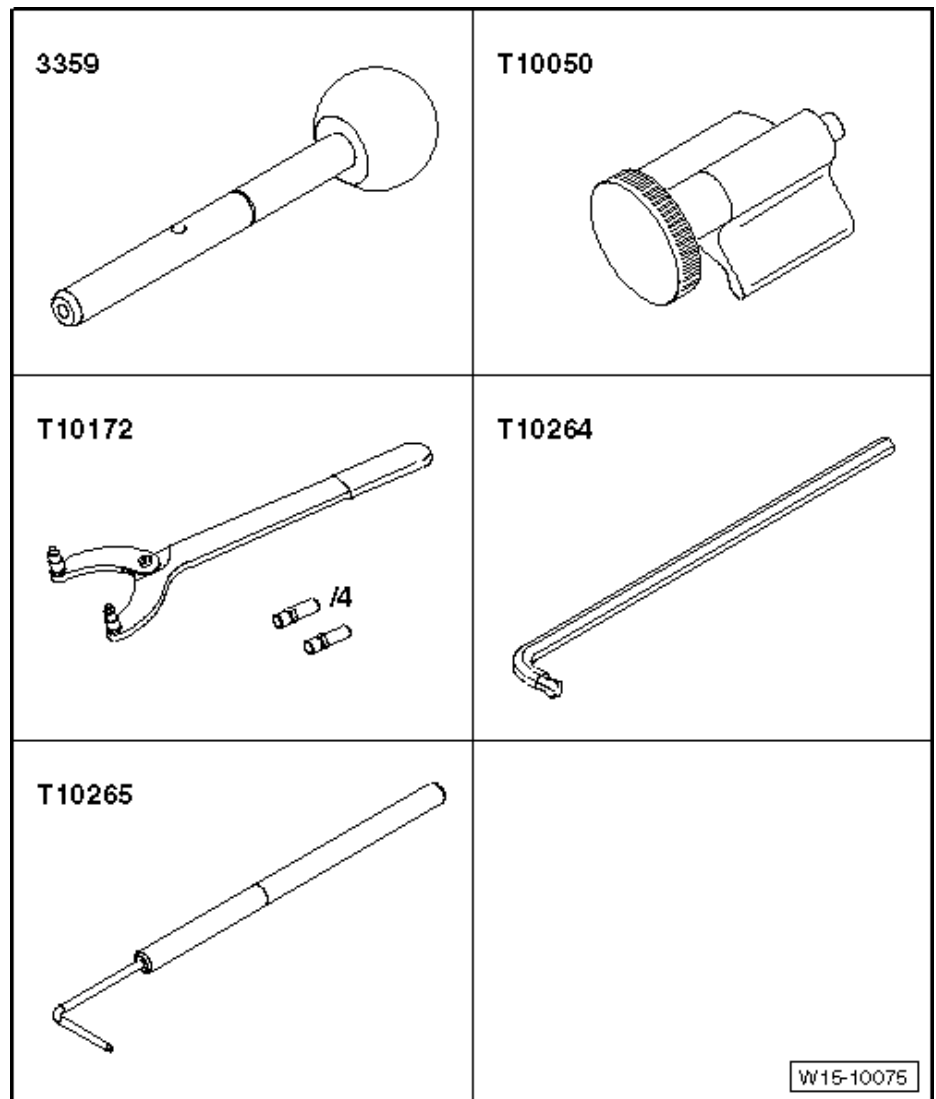

Not illustrated:

- ◆ Torque wrench (5...50 Nm) -V.A.G 1331-
- ◆ Spring-type clip pliers -VAS 5024-

Removing ⇒ [page 117](#).

Installing, tensioning ⇒ [page 119](#).

1.5.1 Removing

Note

Adjustment work on toothed belts must be performed only on cold engines, as the indicator position on the tensioning element varies depending on the engine temperature.



WARNING!

Due to the cramped conditions, note the following when carrying out repairs:

- ◆ *Route all the various lines (e.g. for fuel, hydraulics, coolant and refrigerant, brake fluid and vacuum) and electrical wiring in their original positions.*
- ◆ *Ensure that there is sufficient clearance to all moving or hot components.*

- Open clips -arrows- and remove toothed belt guard.
- Remove poly V-belt ⇒ [page 76](#).
- Remove vibration damper ⇒ [item 29 on page 81](#).

- Remove lower and centre toothed belt guard -arrows- and unscrew securing nut of coolant pipe -1-.

- Position crankshaft at TDC and lock crankshaft toothed belt pulley with crankshaft stop -T10050-. To do this, push crankshaft stop into teeth of belt pulley from face side. Camshaft toothed segment must be at "12 o'clock".

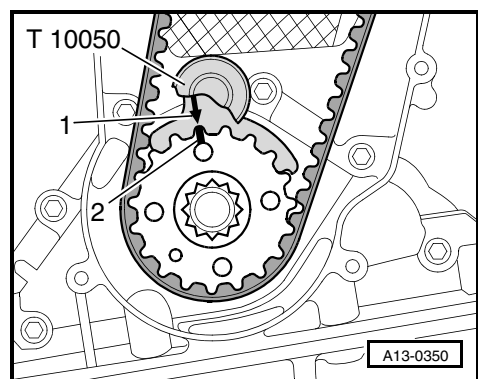
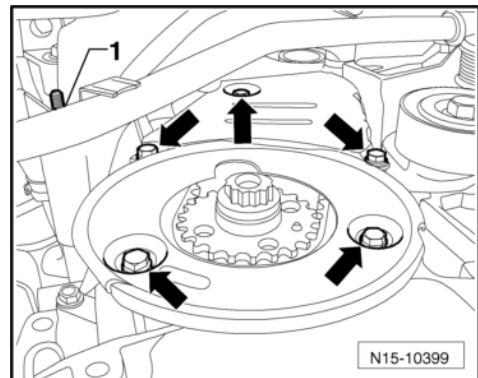
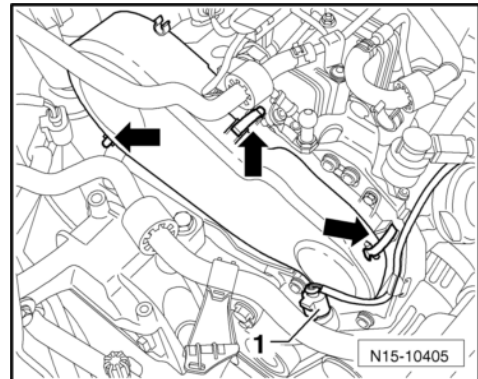

i Note

The markings on the crankshaft toothed belt pulley -2- and the crankshaft stop -T10050- -1- must align. At the same time, the pin of the crankshaft stop -T10050- must engage in the drilling in the sealing flange.

- Mark direction of rotation of toothed belt.



- Loosen securing bolts -1- for camshaft toothed belt pulley.

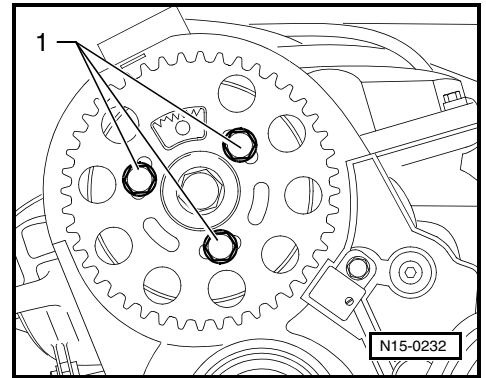

- Loosen securing bolt of coolant pipe -1- and then securing bolts of toothed belt pulley for high-pressure pump -2-.
- Loosen tensioning roller securing nut -1-.

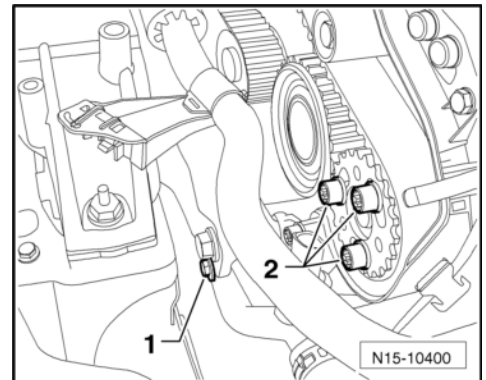

- Turn the eccentric adjuster with the special wrench -T10264- anti-clockwise -arrow- until the tensioning roller can be secured with the locking pin -T10265-.

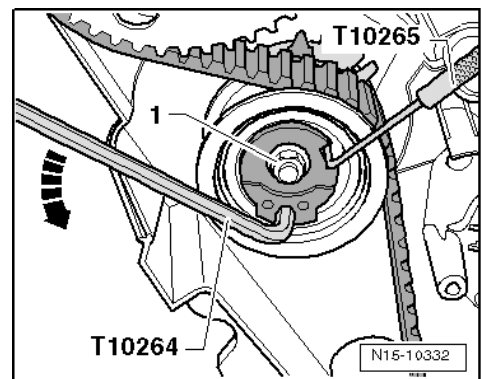

- Now turn eccentric of tensioning roller clockwise -arrow- to stop and tighten securing nut -1- hand-tight.
- Remove toothed belt first from idler roller and then from remaining pulleys.

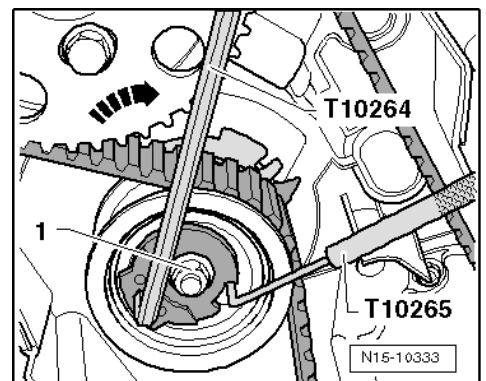

1.5.2 Installing, tensioning

Note

- ◆ Adjustment work on toothed belts must be performed only on cold engines, as the indicator position on the tensioning element varies depending on the engine temperature.
- ◆ If the tensioning roller is to be renewed, the engine bracket must be removed.
- ◆ Renew securing bolts for camshaft pulley and high-pressure pump pulley.



- Tensioning roller must be locked with locking tool -T10265- and secured to right stop.
- Crankshaft is locked using crankshaft stop -T10050-.

i Note

If necessary, turn camshaft hub with counterhold -T10172- and adapters -T10172/4- until camshaft can be secured in position. To do this, hand-tighten at least one securing bolt -1-.

- Lock camshaft hub with locking pin -3359-. To do this, slide locking pin through outer free elongated hole into hole in cylinder head.
- Loosen bolts which had been tightened only hand-tight.

i Note

If necessary, turn hub of high-pressure pump at bolt heads with screwdriver until it can be secured in position.

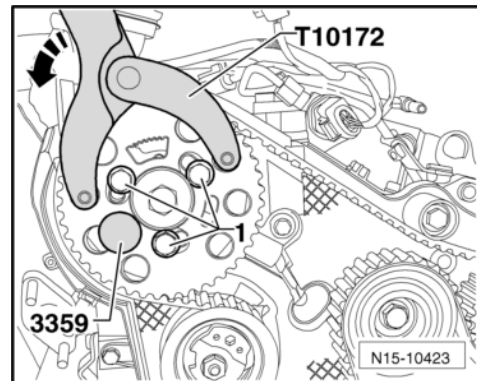

Positioning hub of high-pressure pump

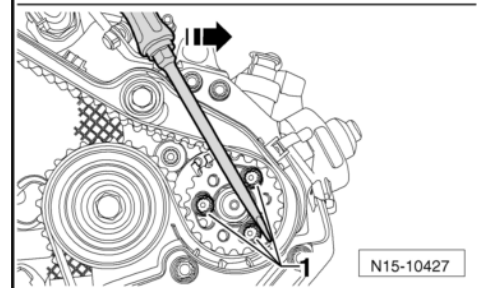
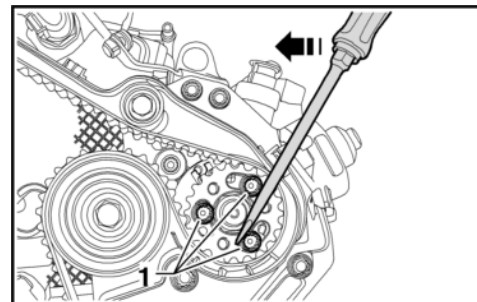

- Lock hub of high-pressure pump with locking pin -3359-. To do this, slide locking pin into adjustment hole outside toothed belt pulley.
- Turn camshaft pulley and toothed belt pulley of high-pressure pump in their elongated holes clockwise to stop.
- Fit toothed belt to crankshaft toothed belt pulley, tensioning roller, camshaft pulley, toothed belt pulley of coolant pump and toothed belt pulley of high-pressure pump.
- Finally, fit toothed belt to idler roller.
- Loosen tensioning roller securing nut and pull out locking tool -T10265-.

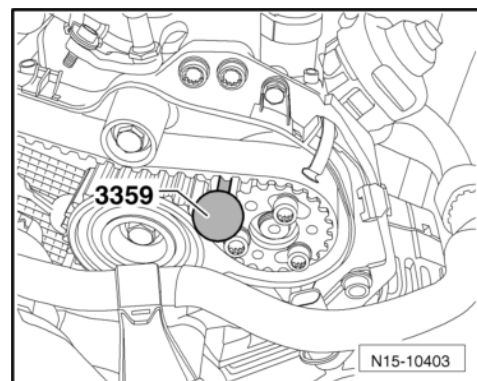

i Note

Ensure that tensioning roller seats correctly in rear toothed belt guard -arrow-.

- Carefully turn tensioning roller eccentric clockwise using angle driver -T10264-. The indicator -2- must lie approx. over centre of gap in base plate (corrected when creating tension).

Ensure that securing nut -1- does not turn as well.

- Hold tensioning roller in this position and tighten tensioning roller securing nut as follows: 20 Nm and then turn 45° further.

- Apply counterhold tool -T10172- as shown. Press counterhold tool -T10172- in direction of arrow, keeping camshaft pulley under tension.

- In this position, first tighten securing bolts -1- of camshaft pulley and of toothed belt pulley for high-pressure pump by hand and then tighten to 20 Nm.

- Remove locking pin -3359- and crankshaft stop -T10050-.

- Turn crankshaft two rotations in engine direction of rotation and set again to TDC No. 1 cylinder.

- Fit crankshaft stop -T10050- again to crankshaft belt pulley.

- Now turn crankshaft in engine direction of rotation until pin of crankshaft stop -arrow- engages in sealing flange from rotational movement.

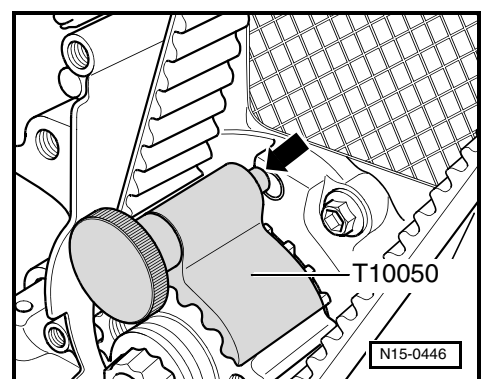
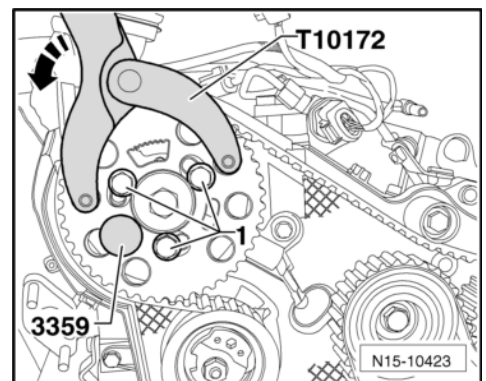
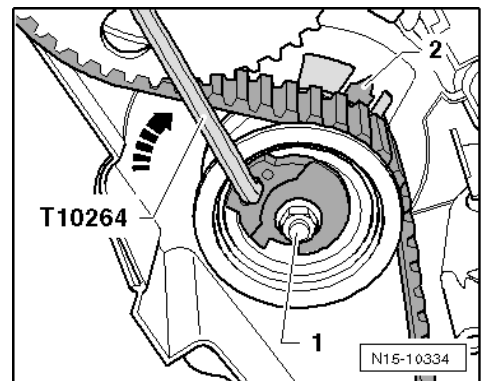
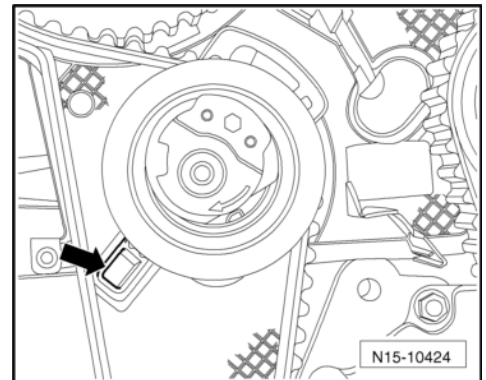



i Note

During the following checking procedure, only the camshaft and crankshaft must be secured in position. It is very difficult to find the securing point of the high-pressure pump hub again. However, a slight deviation -arrow- does not influence the engine operation.

- Check whether:
 - ◆ Camshaft hub can be locked with locking pin -3359-.
 - ◆ Tensioning roller indicator is centred or maximum 5 mm to right of base plate notch.

If camshaft hub cannot be locked:

- Pull crankshaft stop -T10050- back until pin uncovers hole.
- Turn crankshaft in opposite direction of engine rotation slightly past TDC.
- Now turn crankshaft slowly in direction of engine rotation until camshaft hub can be secured in position.
- After locking, loosen securing nuts of crankshaft toothed belt pulley.

If pin of crankshaft stop -T10050- is standing on left next to hole:

- Turn crankshaft in engine direction of rotation until crankshaft stop pin engages in sealing flange whilst turning.
- Tighten securing bolts of camshaft toothed belt pulley by hand first and then tighten to 20 Nm.

If pin of crankshaft stop -T10050- is standing on right next to hole:

- Slightly turn crankshaft in opposite direction of engine rotation.
- Now turn crankshaft in engine direction of rotation until crankshaft stop pin engages in sealing flange whilst turning.
- Tighten securing bolts of camshaft toothed belt pulley by hand first and then tighten to 20 Nm.

Continuation

- Remove locking pin -3359- and crankshaft stop -T10050-.
- Turn crankshaft two rotations in engine direction of rotation and set again to TDC No. 1 cylinder.
- Repeat check.
- If camshaft hub can be secured in position, tighten securing bolts as follows:

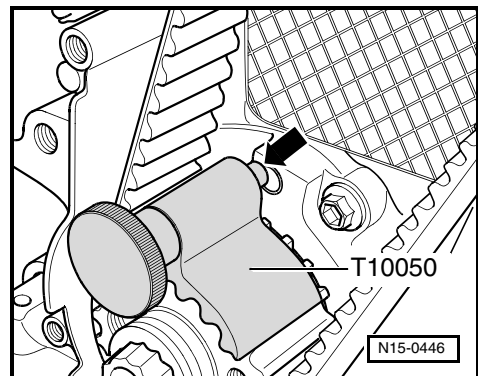
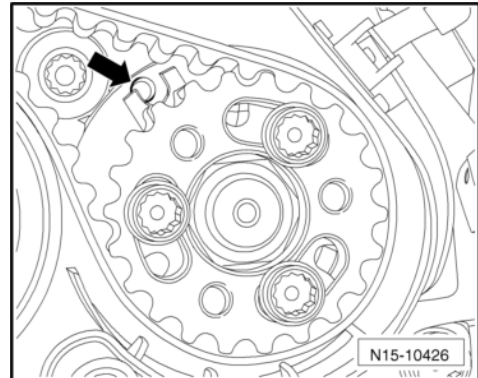



- ◆ Camshaft pulley: Turn 45° further. Counterhold with counterhold tool -T10172- and adapters -T10172/4-.
- ◆ High-pressure pump pulley: Turn 90° further. Counterhold with counterhold tool -T10172- and adapters -T10172/8-.
- Install centre and lower parts of toothed belt guard.
- Install vibration damper/belt pulley: Specified torque: 10 Nm + turn 90° further
- Install poly V-belt ⇒ [page 76](#).
- Install upper toothed belt guard.

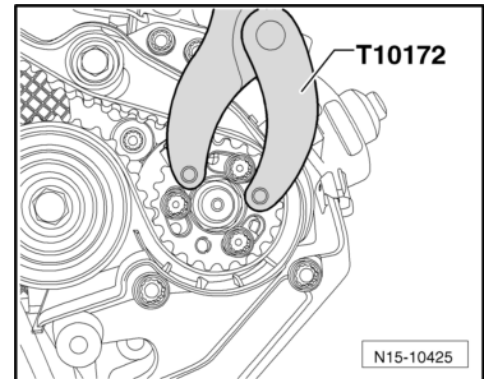

Further assembly is basically the reverse of the dismantling sequence. In the process, note the following:

- ◆ Ensure fuel hoses are tight.
- ◆ Do not interchange fuel supply and return lines (return line is blue or with blue markings and supply line is white).

1.6 Removing and installing cylinder head

Special tools and workshop equipment required

- ◆ Guide pins -3070-
- ◆ Diesel injection pump locking pin -3359-
- ◆ Crankshaft stop -T10050-
- ◆ Counterhold -T10051-
- ◆ Puller -T10052-
- ◆ Bit XZN 10 -T10385-

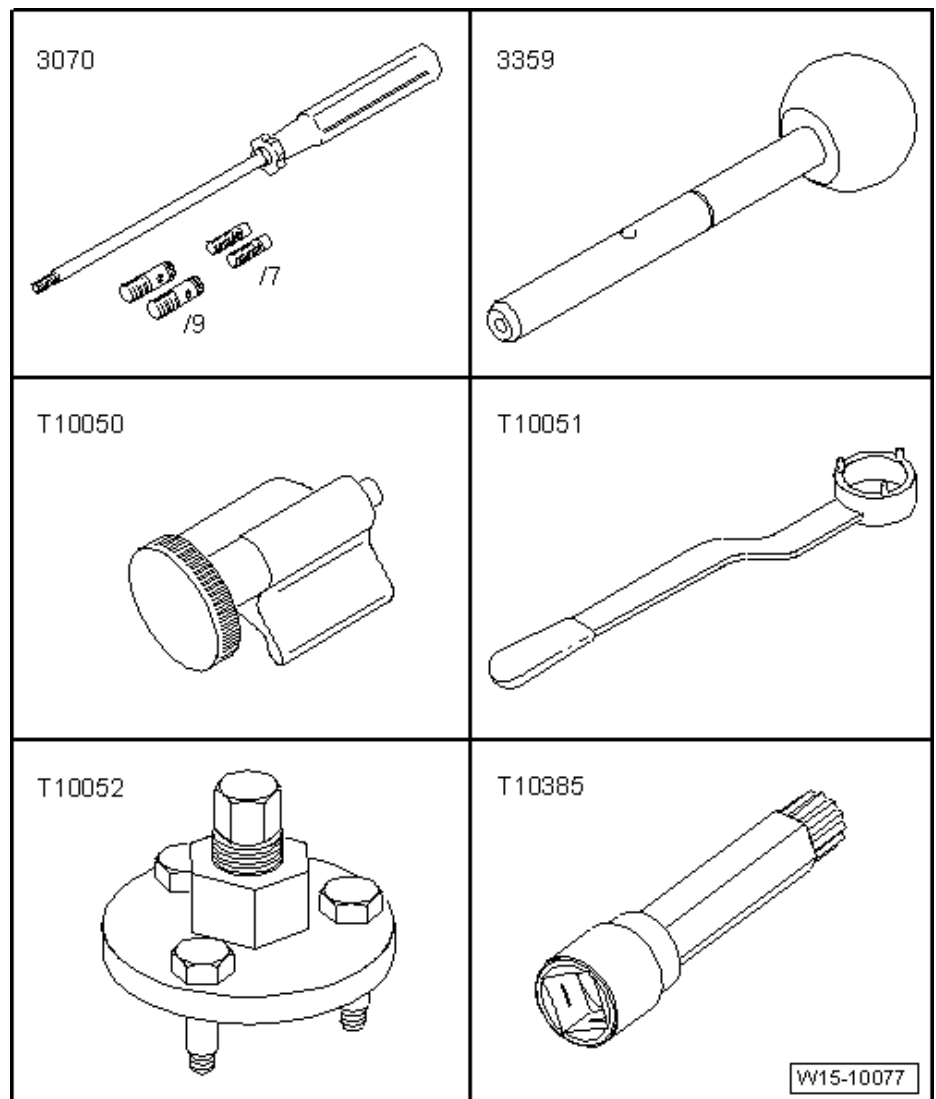

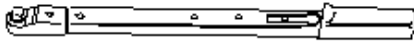
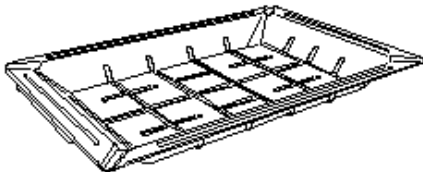

- ◆ Torque wrench -V.A.G 1331-
- ◆ Torque wrench -V.A.G 1332-
- ◆ Drip tray for workshop hoist -VAS 6208-

<p>V.A.G 1331</p> 	<p>V.A.G 1332</p> 
<p>VAS 6208</p> 	
	<p>W15-10078</p>

Not illustrated:

- ◆ Container for removed parts -V.A.G 1698-
- ◆ Spring-type clip pliers -VAS 5024-
- ◆ Engine bung set -VAS 6122-
- ◆ Cable ties

Notes on removing ⇒ [page 124](#).

Notes on installing ⇒ [page 129](#)

1.6.1 Notes on removing



Note

The following procedures contain basic notes for the removal and installation of cylinder heads, more specific information is not possible due to the various configurations.



! WARNING!

Due to the cramped conditions, note the following when carrying out repairs:

- ◆ *Route all the various lines (e.g. for fuel, hydraulics, activated charcoal filter system, coolant, refrigerant, brake fluid and vacuum) and electrical wiring in their original positions.*
- ◆ *Ensure that there is sufficient clearance to all moving or hot components.*

i Note

- ◆ *All cable ties which are opened or cut open during removal must be replaced in the same position when reinstalling.*
 - ◆ *To prevent damage to removed components, place them in the container for removed parts -V.A.G 1698-.*
- Drain coolant ⇒ [page 159](#).
 - Remove cylinder head cover ⇒ [page 208](#).
 - Take toothed belt off camshaft ⇒ [page 117](#), Removing and installing toothed belt.
 - Pull connector -2- off throttle valve module -J338-.

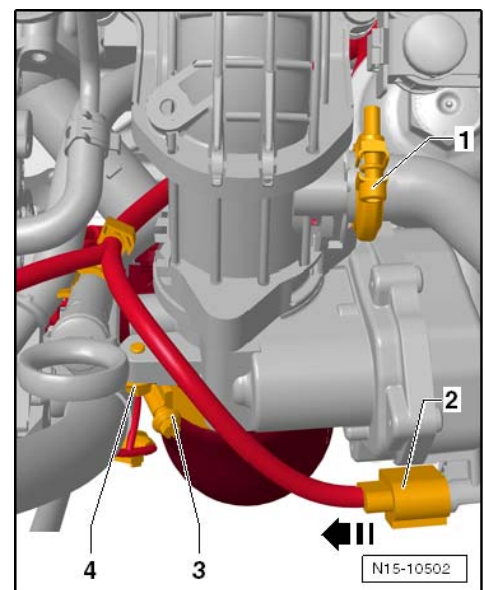



- Unscrew securing bolts -arrows- from charge air pipe and separate connector -1- from charge air pressure sender -G31-.

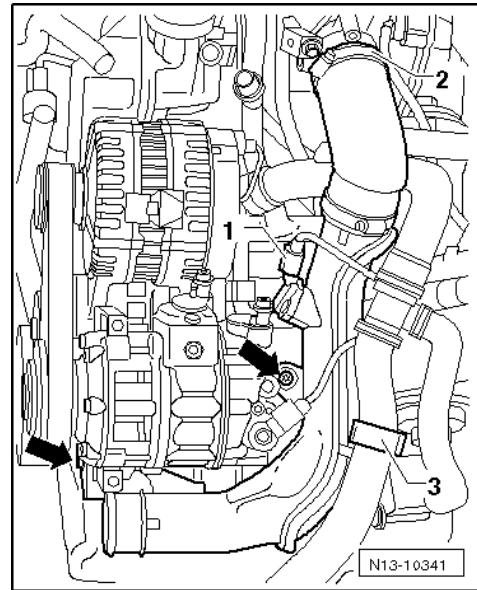

- Open clamp -2-, lay coolant hose -3- to side and remove charge air pipe.
- Disconnect vacuum line from exhauster pump.

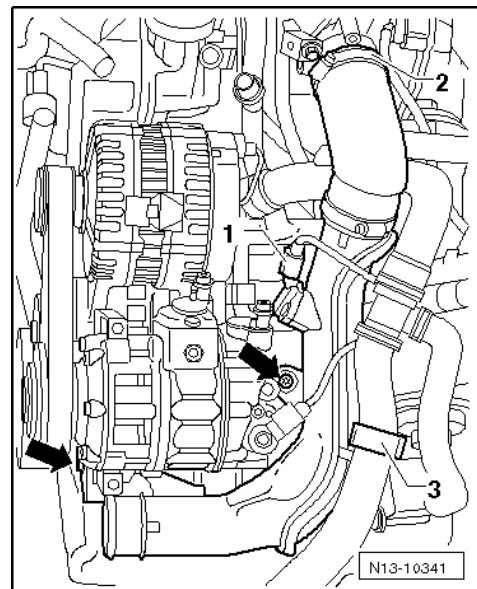

- Unclip engine pre-wiring harness from retainer -arrow-.

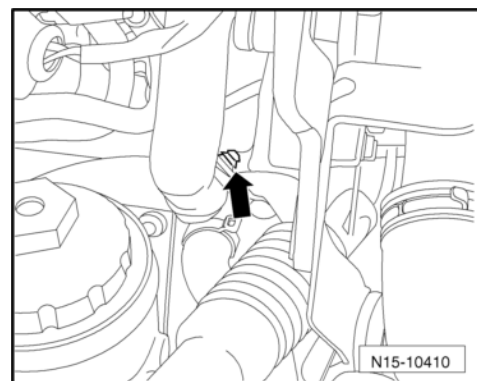



- Pull off vacuum line -arrow-.

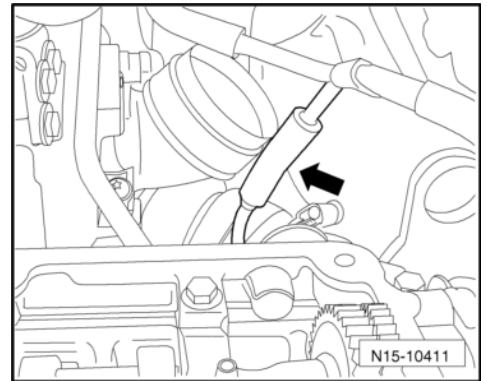

- Unscrew vacuum line attachment -arrow-.
- Unscrew securing bolts of charge air pipe and pull connecting hose off turbocharger.
- Remove exhauster pump from cylinder head ⇒ [page 130](#).

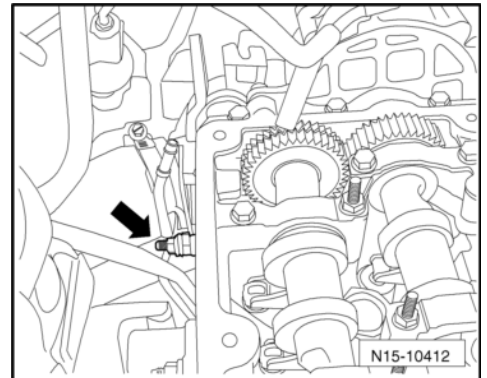

- Disconnect connector -arrow- from coolant temperature sender -G62- and guide line out.

! *Caution!*

Ensure decoupling element of connecting pipe is not bent and thus stretched. There is a danger of cracking.

- Remove exhaust gas recirculation connecting pipes.
- Loosen securing nuts of bracket for diesel particulate filter at crankcase.
- Release connecting clamp between turbocharger and diesel particulate filter.
- Remove securing bolts from bracket for diesel particulate filter.

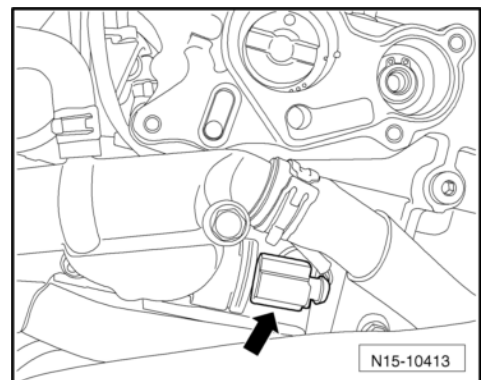

! *Caution!*

The exhaust gas temperature sender 1 -G235- covers the upper threaded connection of the turbocharger support and must not be bent. It must therefore be removed.

- Remove exhaust gas temperature sender 1 -G235- -1-.



- Unscrew bolt -arrow- from support on turbocharger.
- Pull coolant hoses off coolant unions on cylinder head.

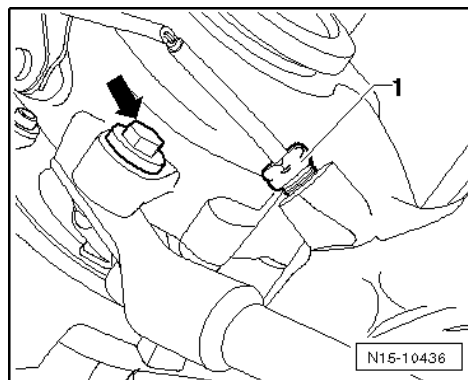

- Unscrew bolt of oil supply line -arrow- and remove oil supply line.
- Remove camshaft toothed belt pulley and pull off camshaft hub using puller -T10052-.

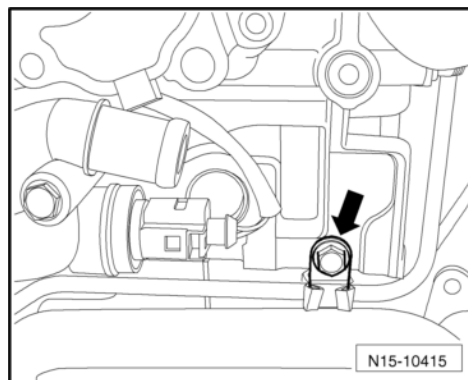

- Unscrew securing bolt -arrow- for toothed belt guard.
- Unscrew securing nut of toothed belt tensioning roller.

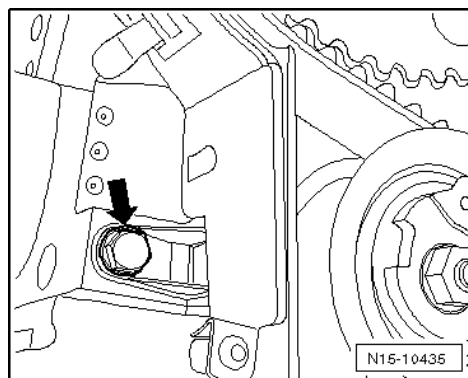

- Disconnect connector for Hall sender -G40- -arrow-.

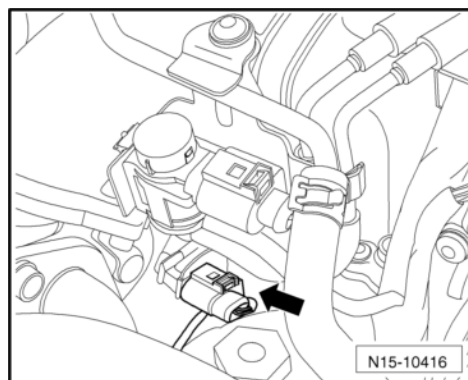



- Maintain sequence when loosening cylinder head bolts.

i Note

- ◆ A second mechanic is required for the removal of the cylinder head.
- ◆ The toothed belt tensioning roller is pulled off the stud when the cylinder head is lifted out.
- ◆ The oil return line of the turbocharger is pulled out of the support when the cylinder head is lifted out.
- ◆ The cylinder head must be guided carefully to prevent damage.

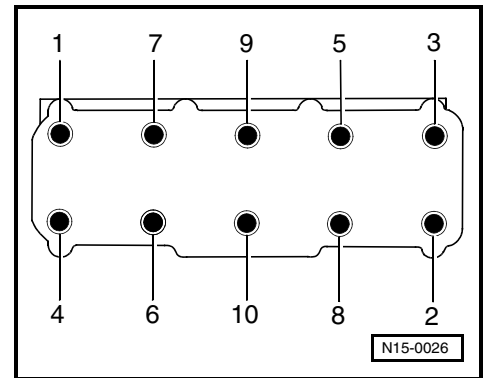

- Guide cylinder head out from toothed belt guard. Prevent toothed belt tensioning roller from falling down.
- Place cylinder head taking care not to bend oil return line. If necessary, place a piece of wood under exhaust manifold.

1.6.2 Notes on installing

i Note

- ◆ Always renew cylinder head bolts.
 - ◆ In event of repair, carefully remove any remaining gasket material from the cylinder head and cylinder block. Take care to avoid producing long scoring marks or scratches. When using abrasive paper do not use a grade less than 100.
 - ◆ Carefully remove emery and abrasive remains.
 - ◆ Do not remove new cylinder head gasket from packaging until it is ready to be fitted.
 - ◆ Handle gasket very carefully. Damage to the silicone coating or the indented area will lead to leaks.
- Before fitting cylinder head, remove crankshaft stop -T10050- and turn crankshaft opposite direction of rotation until all pistons are nearly uniformly below TDC.
 - Cylinder head gasket must lie with identification facing upwards.

i Note

Note identification on cylinder head gasket ⇒ Fig. on page 110.

- To centre, screw guide pins -3070- into outer threaded holes on intake side.

i Note

Tensioning roller must be pushed onto studs when fitting cylinder head.

- Fit cylinder head, install 8 cylinder head bolts and hand-tighten.

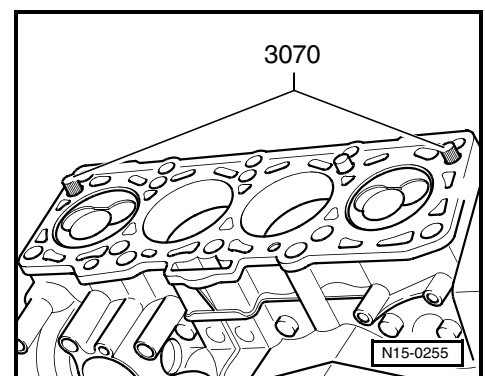



- Remove guide pins using removal tool from 3070 through bolt holes and install cylinder head bolts.
- Tighten cylinder head in 4 stages in sequence shown as follows:

1 - Tighten initially with torque wrench:

- Stage I = 30 Nm
- Stage II = 50 Nm

2 - Turn further with rigid wrench:

- Stage III = 90°
- Stage IV = 90°

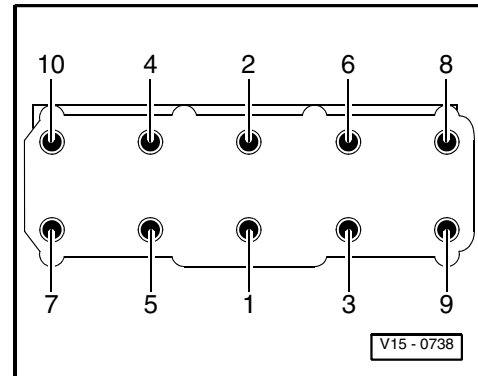

i Note

After repairs it is not necessary to retighten the cylinder head bolts.

- Secure toothed belt rear guard to cylinder head.
- Install hub and camshaft pulley.
- Lock camshaft and high-pressure pump with diesel injection pump locking pin -3359-
- Now rotate crankshaft in direction of rotation to TDC and lock crankshaft using crankshaft stop -T10050-.
- Fit toothed belt ⇒ [page 117](#).

Further installation is carried out in the reverse order. In the process, note the following:

- Install cylinder head cover ⇒ [page 114](#).
- Install poly V-belt ⇒ [page 76](#).
- Fill with coolant ⇒ [page 159](#).
- Then read fault memory of engine control unit and clear fault memory if necessary ⇒ [page 7](#), Clearing fault memory.

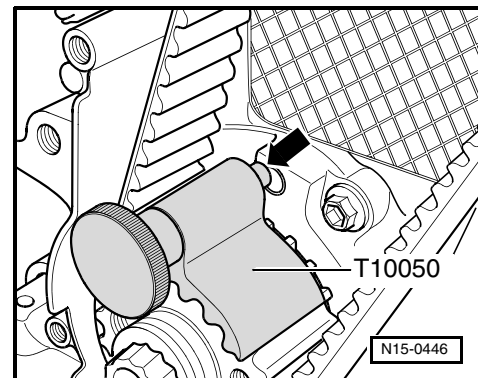

1.7 Removing and installing vacuum pump

Special tools and workshop equipment required

- ♦ Torque wrench -V.A.G 1331/-

⚠ DANGER!

The exhauster pump may, under no circumstances, be dismantled as the vacuum part could otherwise malfunction. This would result in the failure of the brake servo.

Removing

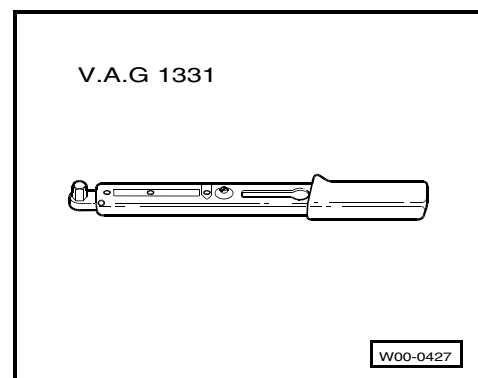



- Pull vacuum line -1- off exhauster pump -4-.
- Unscrew charge air pipe securing bolts.
- Then push charge air pipe downwards slightly to gain access to vacuum pump threaded connections.

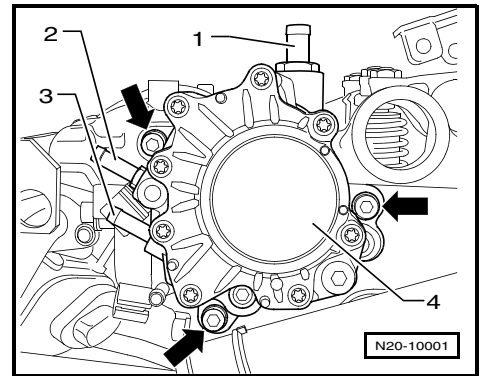

- Remove securing bolts -arrows-.
- Remove exhauster pump -4- from cylinder head.

Installing

Installation is carried out in the reverse order. When installing, note the following:



Note

- ◆ *Ensure that exhauster pump coupling seats properly in camshaft.*
- ◆ *The seal must be renewed.*
- Install vacuum pump and tighten securing bolts to 10 Nm.
- Connect vacuum line -1- from brake servo to exhauster pump.

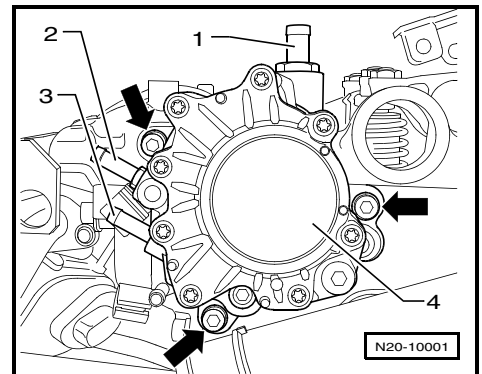

1.8 Checking compression

Special tools and workshop equipment required

- ◆ Jointed spanner -3220-

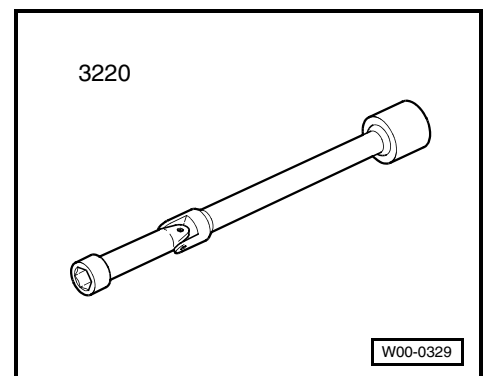



- ◆ Compression tester -V.A.G 1763- with adapter -V.A.G 1763/8-
- ◆ Torque wrench (5...50 Nm) -V.A.G 1331-

Test prerequisites

- All electrical consumers must be switched off.
- Min. engine oil temperature 30 °C.

Test procedure

- Remove glow plug from relevant cylinder using U/J extension and socket, 10 mm -3220- ⇒ [page 338](#).
- Screw in adapter -V.A.G 1763/8- in place of glow plug.
- Check compression using compression tester -V.A.G 1763-.

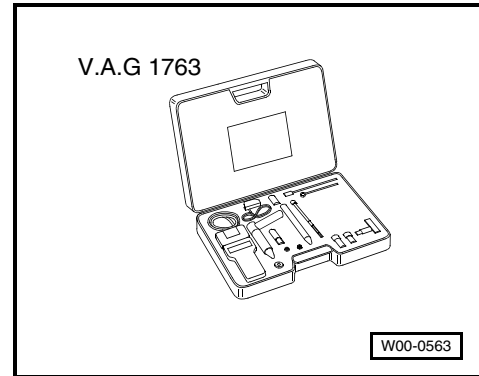

Note

For information on how to use tester, ⇒ Operating instructions.

- Operate starter until tester shows no further pressure increase.

Compression pressures:

New: 25...31 bar

Wear limit: 19 bar

Permissible difference between all cylinders: 5 bar.

- Install glow plug using U/J extension and socket, 10 mm -3220- ⇒ [page 338](#).

Note

Faults will have been stored because the connectors for injectors have been disconnected. Therefore, read fault memory and clear if necessary.

2 Repairing valve gear

Note

Cylinder heads with cracks between the valve seats may be used without reducing engine life, provided the cracks are small and not more than 0.5 mm wide.

Assembly overview - valve gear ⇒ [page 133](#).

Valves ⇒ [page 134](#)

Removing and installing camshaft ⇒ [page 138](#).

Removing and installing camshaft seal ⇒ [page 144](#).

2.1 Assembly overview - valve gear

1 - Seal

- Do not additionally oil or grease the oil seal sealing lip.
- Before installing, remove residual oil from camshaft journal using a clean cloth.
- To install, mask off groove on camshaft taper (e.g. using Sellotape)
- Removing and installing
⇒ page 144.

2 - 10 Nm

3 - 10 Nm

4 - Bearing frame

- Observe sequence when loosening and tightening
⇒ page 138.
- Seal using silicone adhesive sealant -D 176 501 A1-.

5 - Exhaust camshaft

6 - Inlet camshaft

7 - Roller rocker finger

- Mark installation position
- Do not interchange.
- Check roller bearing for ease of movement
- Oil contact surface.

8 - Hydraulic compensation element

- Mark installation position
- Lubricate contact surfaces before installing

9 - Valve

- Do not rework. Only lapping in is permitted.
- Mark installation position for re-installation
- Valve dimensions ⇒ page 134
- Checking valve guides ⇒ page 134

10 - Cylinder head

- See note ⇒ page 108.
- Removing and installing ⇒ page 114.

11 - Valve stem seal

12 - Valve spring

13 - Valve spring plate

14 - Valve cotter

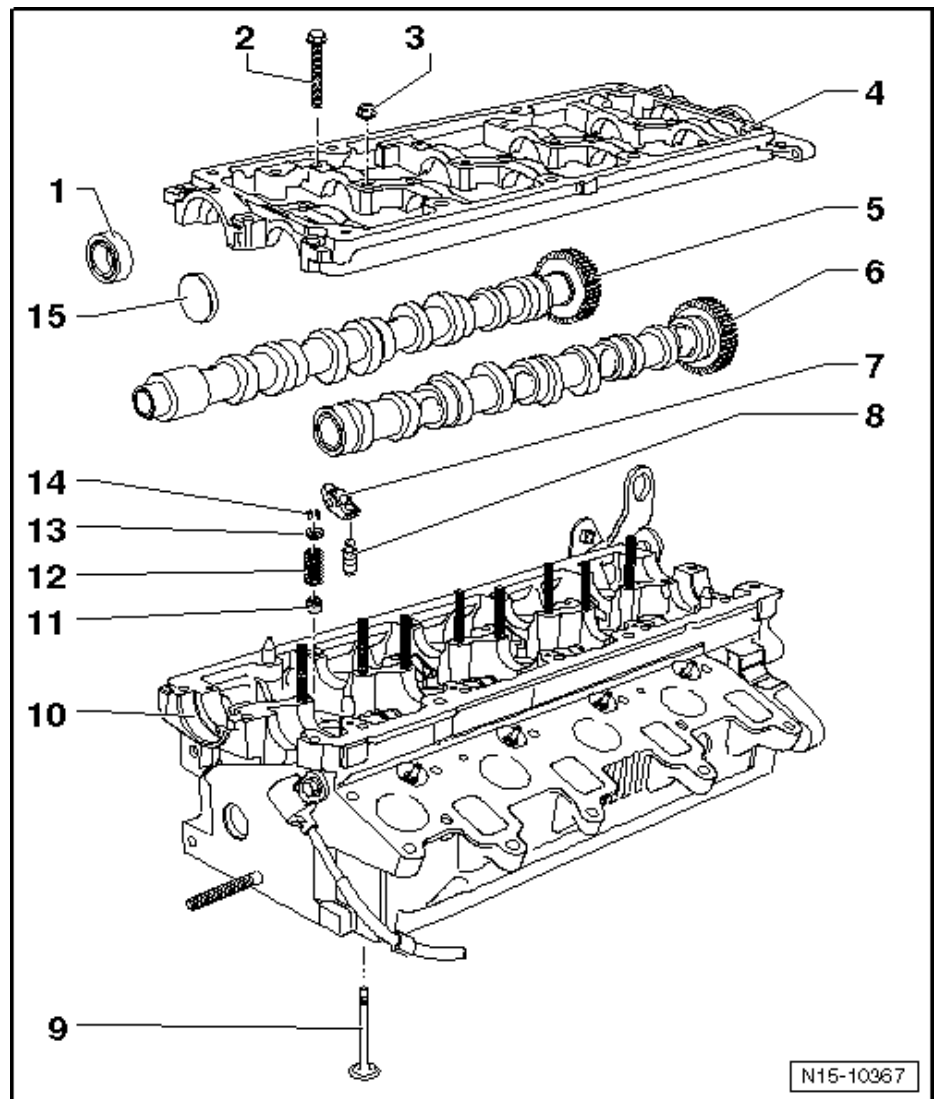



15- Cover

- Renew.

2.2 Valves

2.2.1 Valve dimensions

Note

Valves must not be reworked. Only lapping-in is permitted.

Dimension		Inletvalve	Exhaust valve
∅ a	mm	26,60	26,00
∅ b	mm	5,940	5,940
c	mm	99,30	99,10
α	∠°	45	45

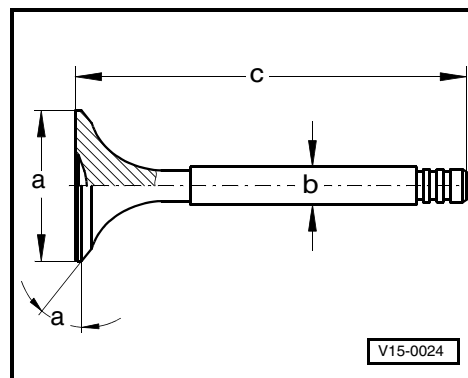

2.2.2 Checking valve guides

Special tools and workshop equipment required

- ◆ Universal dial gauge bracket -VW 387-
 - ◆ Dial gauge
- Insert new valve into guide. The end of the valve stem must be flush with the guide. Due to differences in stem diameters, use only an inlet valve in inlet guide and an exhaust valve in exhaust guide.
 - Determine rock. Wear limit: max. 1.3 mm
 - Cylinder head must be renewed if rock exceeds wear limit.

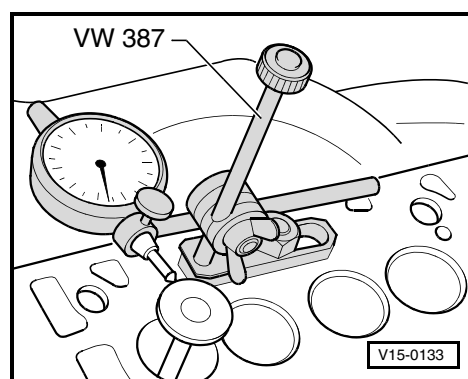
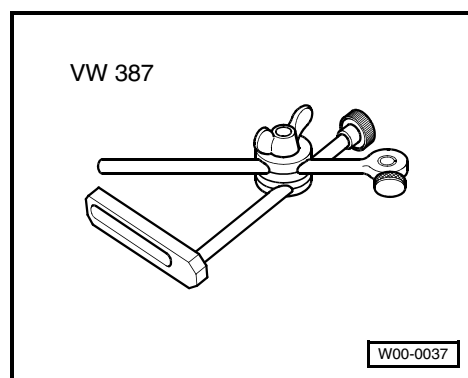



2.3 Renewing valve stem seals

Special tools and workshop equipment required

- ◆ 10 mm jointed spanner -3220-
- ◆ Valve stem seal puller -3364-
- ◆ Valve stem seal fitting tool -3365-
- ◆ Removal and installation device for valve cotters -VAS 5161- with guide plate -VAS 5161/23- and knurled spacer ring -VAS 5161/23-1-

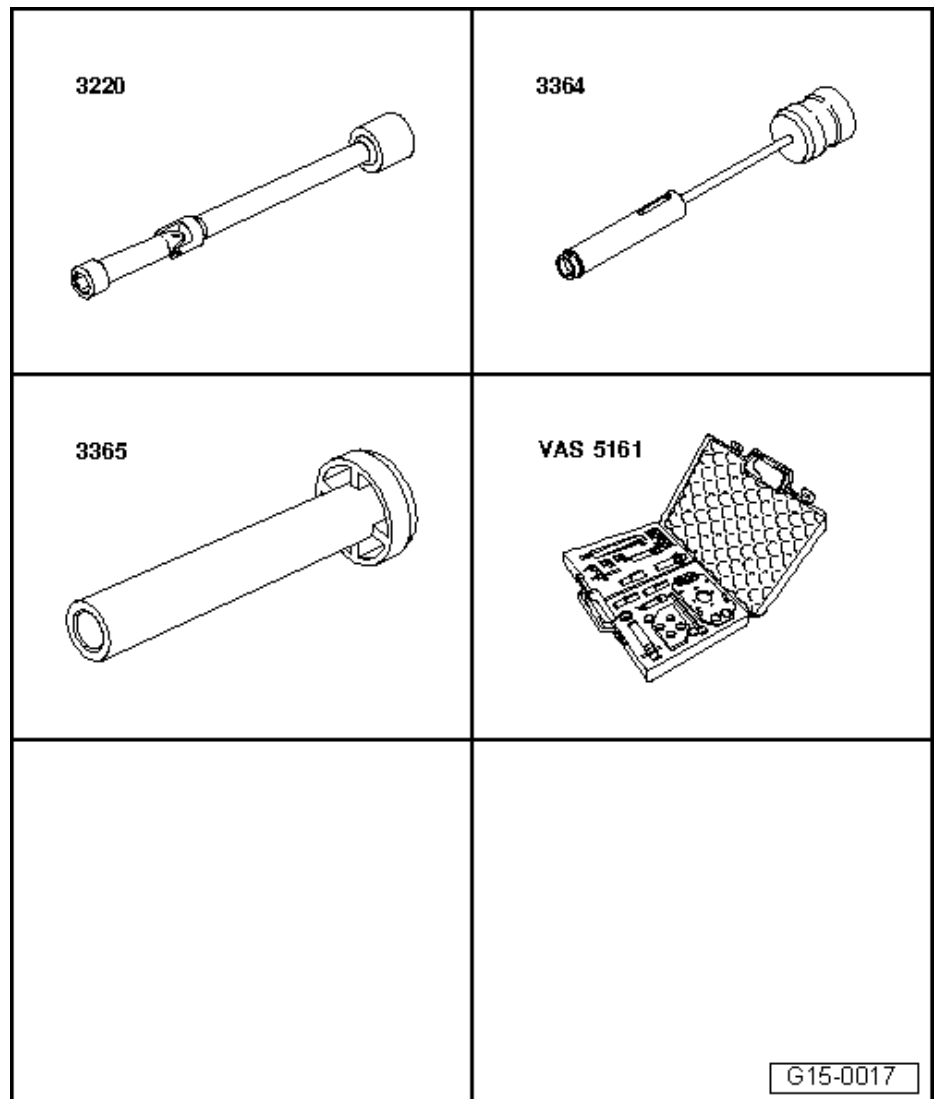

Procedure

- Remove all glow plugs using U/J extension and socket -3220- ⇒ [page 338](#).
- Removing camshafts ⇒ [page 138](#).
- Fit guide plate -VAS 5161/23- onto cylinder head.
- Secure guide plate on intake manifold side with knurled screw -VAS 5161/12- and tighten it hand-tight to studs using M6 collarless nuts -1-.
- Screw sealing pin -VAS 5161/10- into guide plate.

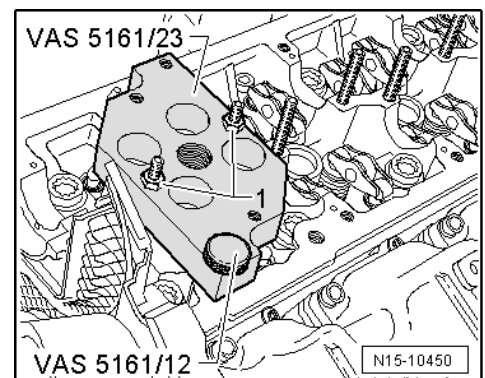



- Screw adapter -VAS 5161/11- hand-tight into glow plug hole of relevant cylinder.

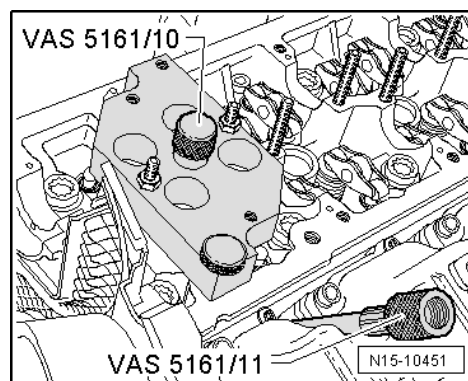

- Insert drift -VAS 5161/3- into guide plate and knock valve cotters loose using a plastic hammer.

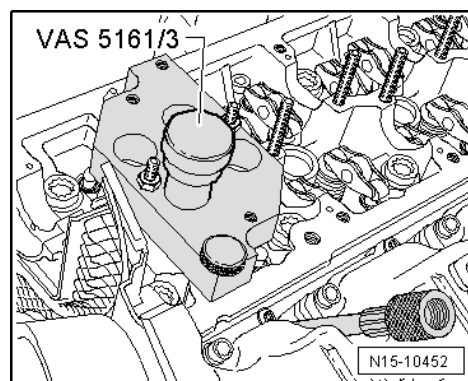

- Screw engaging fork -VAS 5161/5- with snap-in device -VAS 5161/6- into guide plate.
- Slide knurled spacer ring -VAS 5161/23-1- onto assembly cartridge -VAS 5161/8-.
- Connect adapter -VAS 5161/11- to compressed air line using a commercially available connection piece, and apply constant air pressure.

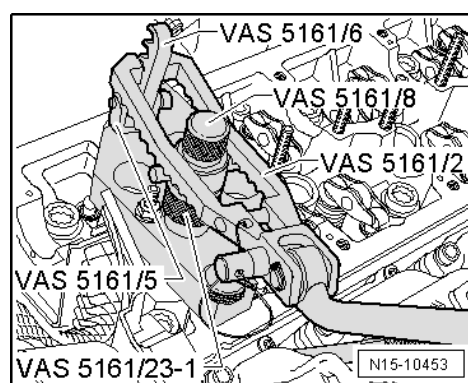

- Minimum pressure: 6 bar
- Attach pressure fork -VAS 5161/2- to snap-in device and push assembly cartridge down.
- At the same time, turn knurled screw of assembly cartridge clockwise until tips engage in valve cotters.
- Move knurled screw back and forth lightly to press apart valve cotters and capture them in the assembly piece.
- Release pressure fork.
- Take out assembly cartridge with knurled spacer ring, valve plate and valve spring.
- Remove valve stem oil seals using valve stem seal puller -3364-.

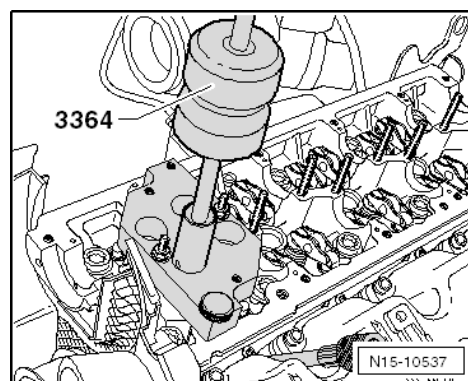

i Note

A plastic sleeve -A- is included with the new valve stem oil seals.

- Fit plastic sleeve -A- onto valve stem to prevent damage to new valve stem oil seal -B-.
- Lightly lubricate sealing lip of valve stem oil seal.
- Slip valve stem oil seal over plastic sleeve.
- Carefully press valve stem oil seal onto valve guide using valve stem seal fitting tool -3365-.
- If necessary, use a plastic head hammer and tap lightly on fitting tool until valve stem oil seal is fitted to stop.
- Remove plastic sleeve.
- Insert valve spring and valve spring plate into cylinder head.
- If valve cotters have been removed from assembly cartridge, they need to be put into insertion device -VAS 5161/18- first.

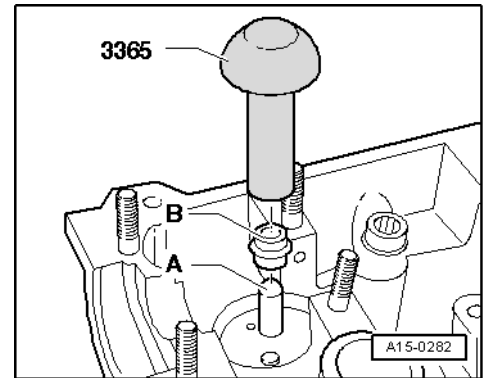

i Note

Larger diameter of valve cotters faces upwards.

- Press assembly cartridge onto insertion device from above and pick up valve cotters.
- Re-insert assembly cartridge -VAS 5161/8- into guide plate.
- Push pressure fork down and pull knurled screw upwards while turning to left and right - this will insert the valve cotters.
- Release pressure fork with knurled screw still in pulled position.

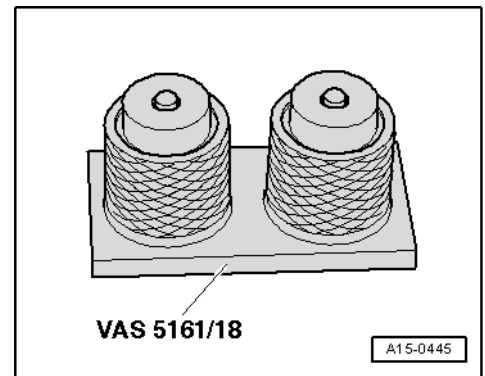

Installation is carried out in the reverse order; note the following:

- Install glow plugs ⇒ [page 338](#).
- Install the camshafts ⇒ [page 138](#).

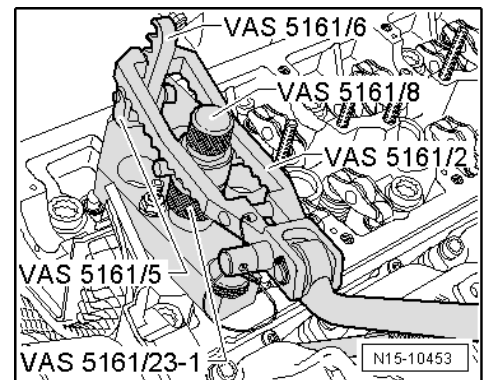

i Note

- ◆ Engine is not to be rotated for approx. 30 minutes after installing camshafts. The hydraulic compensation elements must settle (otherwise valves will strike pistons).
- ◆ After working on valve mechanism, carefully turn engine by hand at least 2 complete revolutions to ensure that no valve strikes piston when engine is started.



2.4 Removing and installing camshaft

Special tools and workshop equipment required

- ◆ Diesel injection pump locking pin -3359-
- ◆ Counterhold -T10051-
- ◆ Puller -T10052-
- ◆ Camshaft insertion tool -T40094-
- ◆ Camshaft clamping tool -T40095-
- ◆ Camshaft fitting tool -T40096-

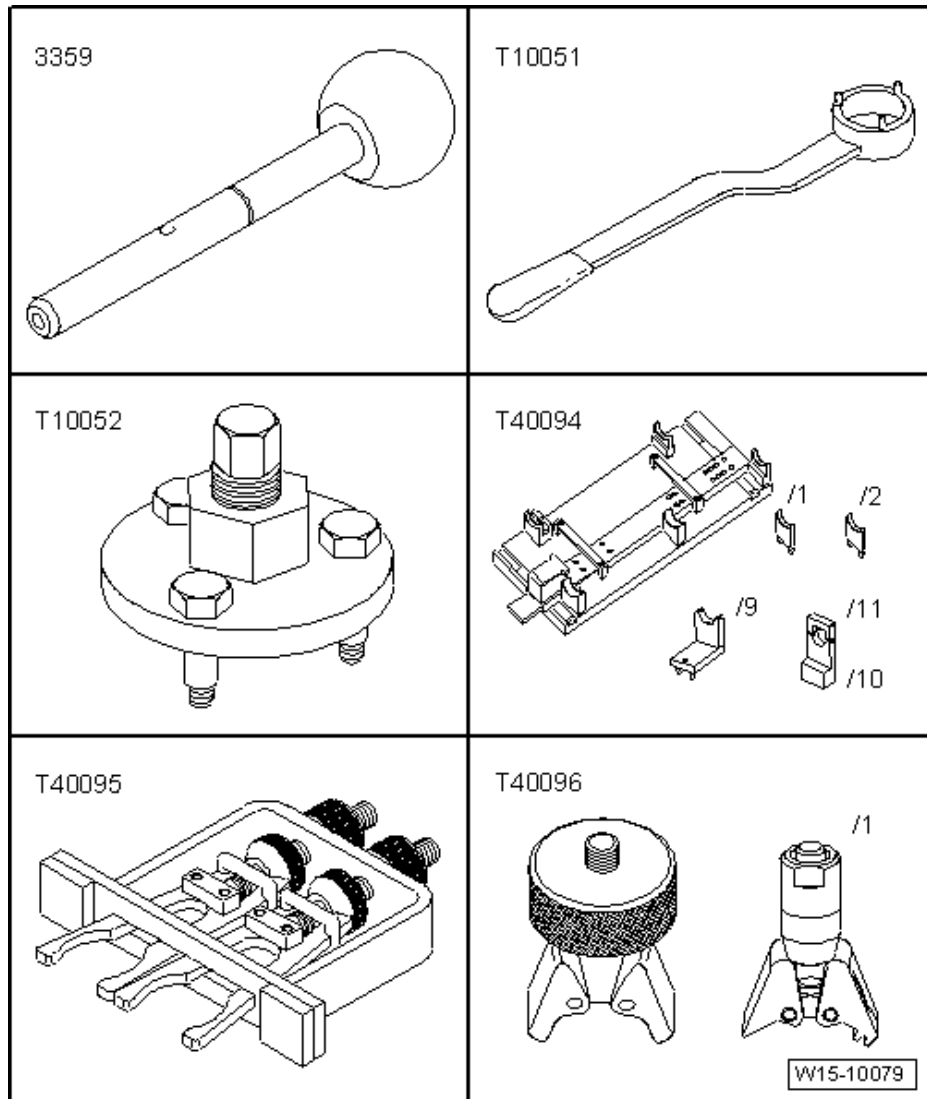

- ◆ Torque wrench -V.A.G 1331/-

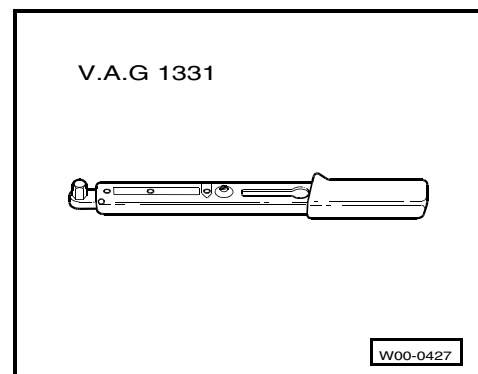



- ◆ Torque wrench -V.A.G 1332/-
- ◆ Silicone adhesive sealant -D 176501 A1-

Removing ⇒ [page 139](#).

Installing ⇒ [page 140](#).

2.4.1 Removing

- Take toothed belt off camshaft and high-pressure pump
⇒ [page 117](#), Removing, installing and tensioning toothed belt.
- Remove cylinder head cover ⇒ [page 114](#).
- Remove securing bolts for camshaft toothed belt pulley -1-.
- Detach camshaft sprocket from hub.

- Counterhold hub with counterhold tool -T10051- and loosen securing bolt -1- of hub.
- Loosen hub securing bolt about 2 turns.

- Fit puller -T10052- and align it with holes in hub.
- Tighten securing bolts -1-.
- Apply tension to hub by evenly tightening puller -2- until hub separates from taper of camshaft.

Note

When doing this, hold puller with 30 mm spanner.

- Remove hub from taper of camshaft.
- Remove exhauster pump ⇒ [page 130](#).

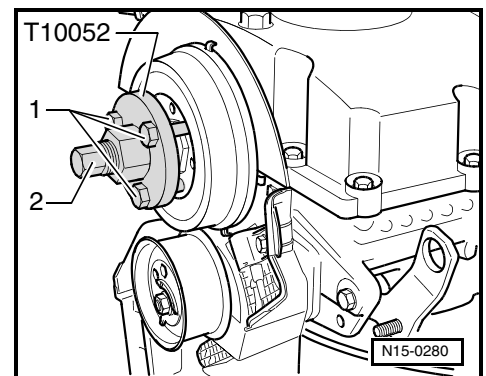
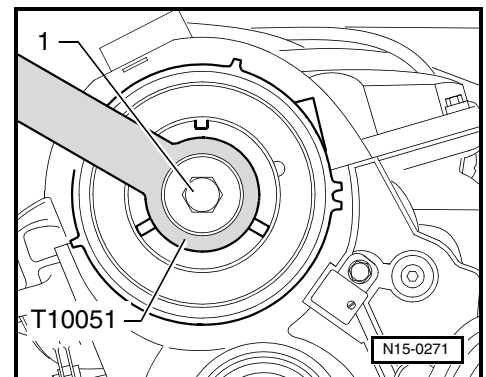
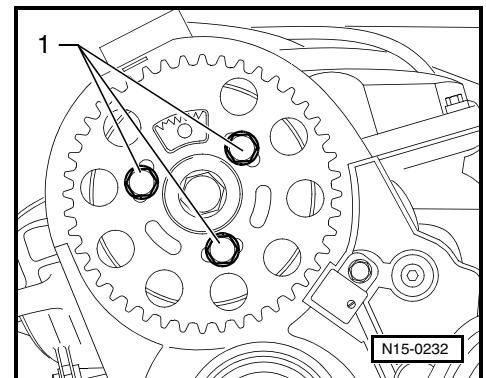
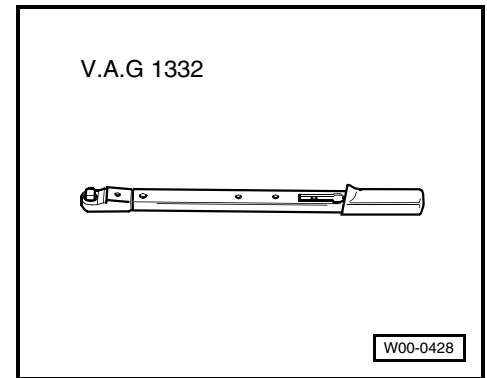



- Remove securing bolts of bearing frame in sequence -24...1-.
- Remove bearing frame.
- Carefully take out camshafts.

2.4.2 Installing

Note

Seal parting surface between bearing frame and cylinder head using silicone adhesive sealant -D 176 501 A1-.

Caution!

The camshafts may **ONLY** be installed using the camshaft insert tool -T40094- as described in the following. The axial bearings in the bearing frame will otherwise be damaged beyond repair and the cylinder head will have to be renewed.

- Remove remaining sealant and from cylinder block and retaining frame using, for example, a rotating plastic brush.

Caution!

Make sure that no sealant residue gets into the cylinder head or the bearings.

- Clean sealing surfaces; they must be free of oil and grease.
- Lubricate running surfaces of camshafts.

Set up camshaft insertion tool -T40094- as follows:

- Remove supports -T40094/3-, -T40094/4- and -T40094/5- from base plate. Threaded connection is accessible from below.

Note

If the supports of the camshaft fitting tool -T40094- are not marked at present, mark the removed supports, e.g. with number stamps, so they can be fitted in the original positions later.

- Install supports -T40094/9- and -T40094/10- instead at vacant outer places.
- Place support -T40094/2- at position labelled "A" and support -T40094/1- at position labelled "F".
- First position inlet camshaft as illustrated. Ensure that indentation -arrow- for cylinder head bolt faces "outwards".

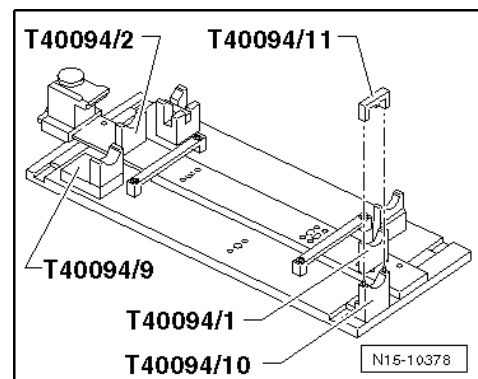
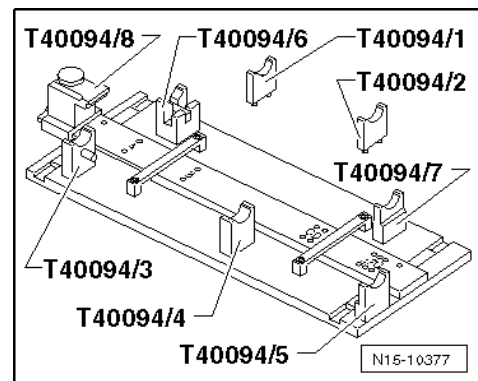
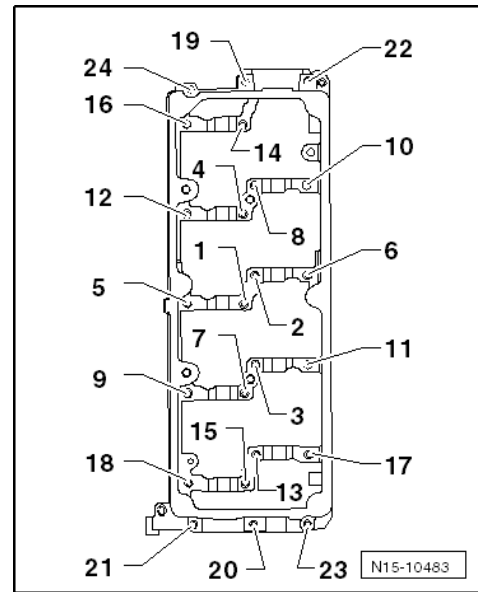



- Set 0.50 mm feeler gauge in place and push support -T40094/8- into groove on inlet camshaft.

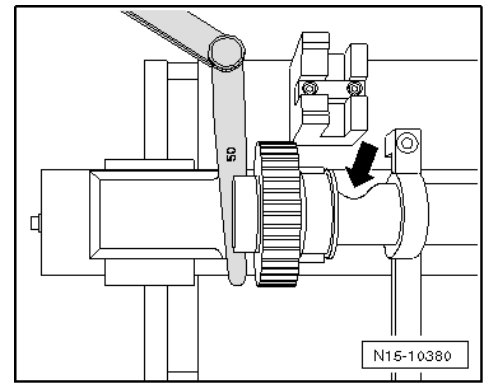

- Now set exhaust camshaft in place and lock by inserting cover T40094/11- into groove -arrow-.
- Fit clamping tool -T40096/1- onto exhaust camshaft gears.

⚠ Caution!

Ensure that the clamping jaw marked with an arrow is seated on the wider gear.

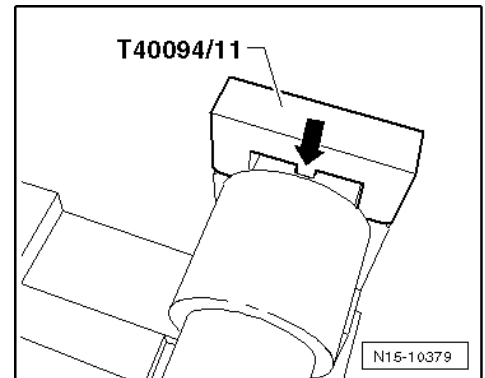

- Tighten clamping tool -T40096/1- using knurled thumb wheel so that faces of gear teeth are in alignment. If necessary, use 13 mm open-end spanner.
- Slide exhaust camshaft towards inlet camshaft until gear teeth engage.
- Fit bearing frame onto camshafts.
- All camshaft bearings must be seated on the camshafts.

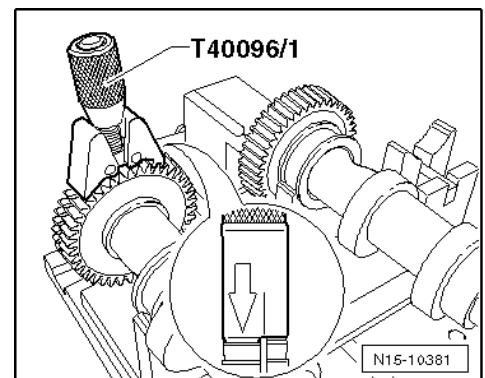

- Set clamping tool -T40095- in place as illustrated in order to hold camshafts in position in bearing frame.
- Remove cover -T40094/11-.
- Pull support -T40094/8- out of inlet camshaft groove.

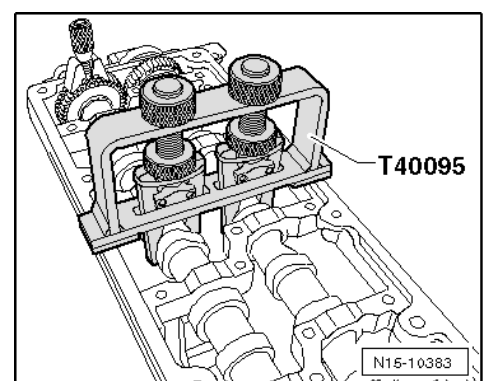



- Cut off nozzle on tube at front marking (∅ of nozzle approx. 2 mm).
- Apply beads of sealant (approx. 2...3 mm wide) -arrows- onto clean sealing surfaces of cylinder head as illustrated.

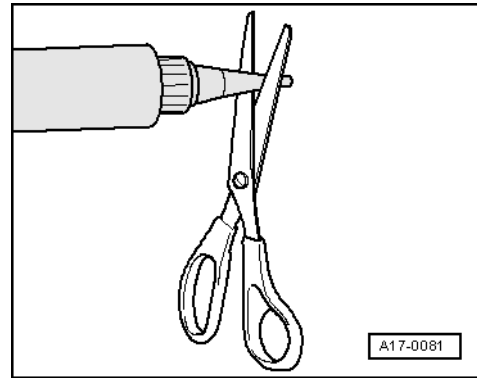

i Note

The sealant beads must not be thicker than specified, otherwise excess sealant could enter the camshaft bearings.

- Take camshafts out of camshaft fitting tool -T40094- together with bearing frame and clamping tool -T40095-.
- Carefully position camshafts and bearing frame in cylinder head.

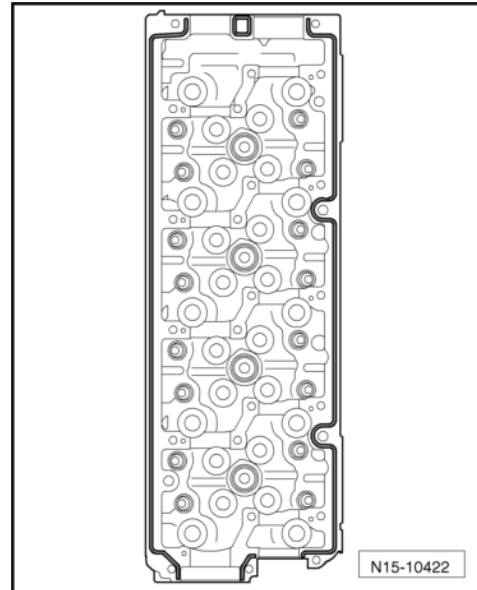

- First screw on securing bolts of bearing frame hand-tight in sequence -1...24-.
- The retaining frame should make contact with the cylinder head over the complete surface.
- Tighten retaining frame bolts to final torque in the sequence -1...24-. Specified torque: 10 Nm
- Remove clamping tool -T40095- and camshaft fitting tool -T40096/1-.
- Renew camshaft oil seal ⇒ [page 144](#).
- Using a suitable drift, knock new sealing cap (core plug) ⇒ [item 15 on page 134](#) in cylinder head until flush.

Perform further installation in reverse order, paying attention to the following:

i Note

- ♦ *Wait about 30 minutes after installing the camshafts before starting the engine. The hydraulic compensation elements must settle (otherwise valves will strike pistons).*
- ♦ *After working on the valve gear, turn the engine carefully at least 2 rotations by hand to ensure that none of the valves make contact when the starter is operated.*

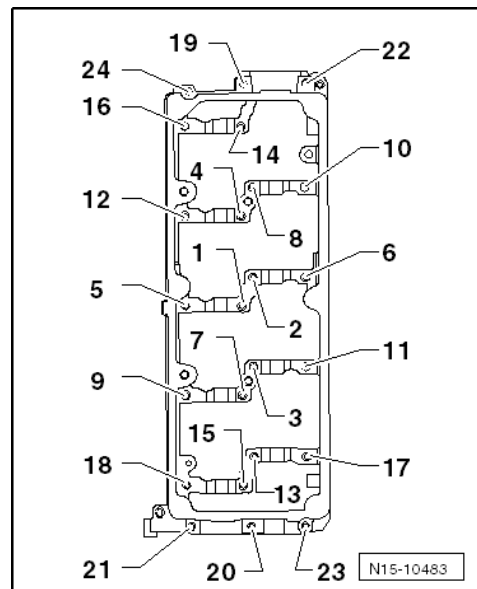

- Fit hub onto camshaft.
- Tighten hub securing bolt -1- to 100 Nm. To do this, use counterhold -T10051-.
-

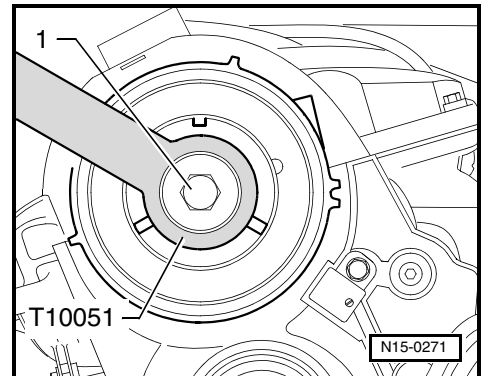

- Push camshaft toothed belt pulley onto hub.

i Note

The toothed segment -arrow- of the camshaft belt pulley must be on top.

- Hand tighten securing bolts -1- to camshaft toothed belt pulley so that there is no play.
- Lock hub using locking pin -3359-.
- Install toothed belt and adjust valve timing ⇒ [page 117](#).
- Install exhauster pump ⇒ [page 130](#).
- Install cylinder head cover ⇒ [page 114](#).

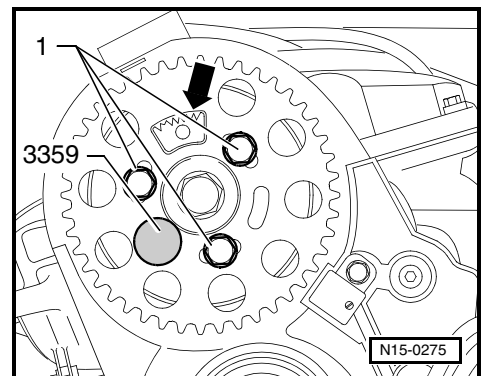





2.5 Removing and installing camshaft oil seal

Special tools and workshop equipment required

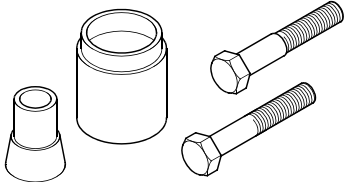
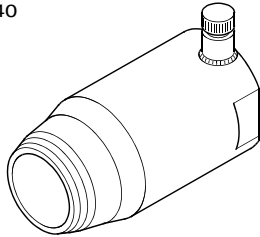
- ◆ Fitting tool -10-203-
- ◆ Oil seal extractor -3240-
- ◆ Torque wrench (5...50 Nm) -V.A.G 1331-
- ◆ Torque wrench (40...200 Nm) -V.A.G 1332-
- ◆ Bolt M12×1.5×65

<p>10-203</p> 	<p>3240</p> 
<p>V.A.G 1331</p> 	<p>V.A.G 1332</p> 
	<p>W15-0078</p>

Removing ⇒ [page 144](#).

Installing ⇒ [page 145](#).

2.5.1 Removing

- Take toothed belt off camshaft and high-pressure pump
⇒ [page 117](#), Removing, installing and tensioning toothed belt.
- Remove camshaft toothed belt pulley and hub
⇒ [page 138](#), Removing and installing camshaft.



- Insert thrust piece -3240/1- into camshaft.
- Unscrew inner part of oil seal extractor 3240 two turns (approx. 3 mm) from outer part and lock in position with knurled screw.

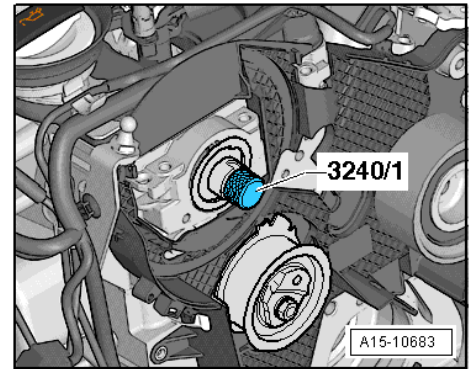

- Lubricate threaded head of oil seal extractor, place it in position and, exerting firm pressure, screw it into oil seal as far as possible.
- Loosen knurled screw and turn inner part against camshaft until oil seal is pulled out.

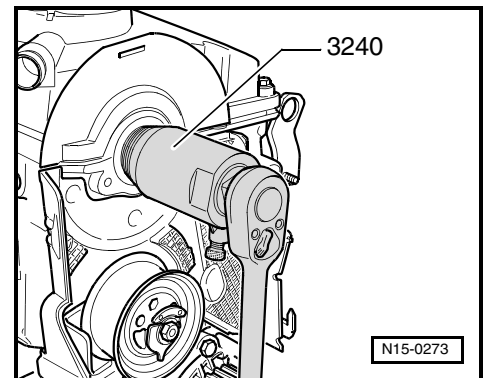

2.5.2 Installing

Note

The oil seal sealing lip must not be additionally oiled or greased.

- Remove oil residue from end of camshaft journal using a clean cloth.
- Tape over groove in taper of camshaft (e.g. with Sello-tape).
- Fit guide sleeve of fitting tool -10 - 203- onto camshaft as shown in illustration.
- Carefully slide oil seal -1- over guide sleeve onto camshaft.

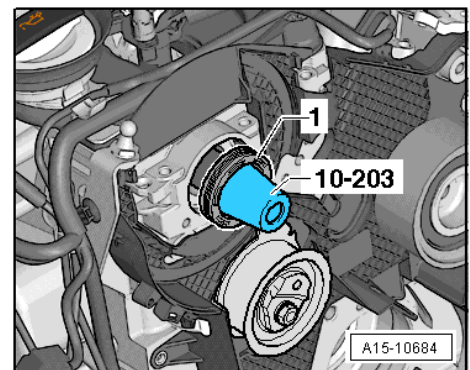

- Press seal in to stop using thrust piece from fitting tool 10-203 and bolt M12×1.5x75.
- Install camshaft pulley and hub ⇒ [page 138](#), Removing and installing camshaft.
- Install toothed belt(s) and adjust timing ⇒ [page 117](#), Removing, installing and tensioning toothed belt.

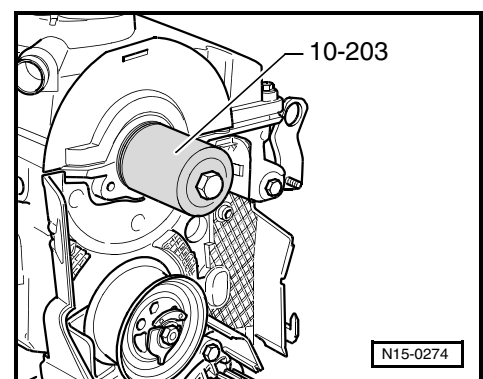



17 – Lubrication

1 Engine oil

Note

The oil level must not be above the max. mark - danger of damage to catalytic converter! Markings ⇒ [page 146](#), Checking engine oil level.

Oil capacities ⇒ [page 146](#).

Engine oil specifications ⇒ [page 146](#).

Checking engine oil level ⇒ [page 146](#).

1.1 Oil capacities

- ♦ With oil filter change: 4.3 l
- ♦ Without oil filter change: 4.0 l

1.2 Engine oil specifications

Only use engine oil conforming to VW standard 50700.

1.3 Checking engine oil level

Markings on oil dipstick

- 1 - min. mark
- 2 - max. mark
- a - Min mark area: replenish with max. 0.5 l of engine oil!
- b - Oil level within central area: Can be replenished with engine oil.
- c - Max. mark area: Do not replenish with engine oil.

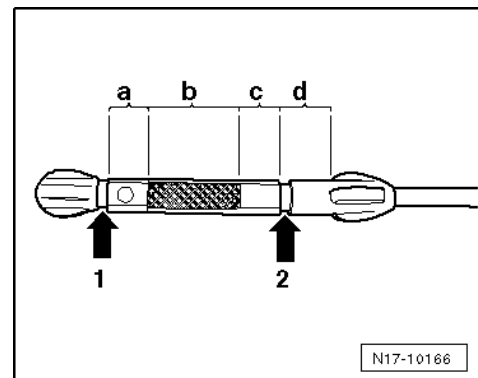

2 Parts of lubrication system

Caution!

Finding metal shavings or a large quantity of small metal particles during engine repair could indicate that the crankshaft bearings or conrod bearings are damaged. To prevent this from causing further damage, perform the following repairs:

Thoroughly clean oil passages,

Renew oil spray jets,

Renew oil cooler,

Renew oil filter element.

Note

Before carrying out repair work, secure engine on engine and gearbox support -VAS 6095- using universal mounting -VAS 6095/1-.

Observe safety precautions ⇒ [page 208](#).

Observe rules for cleanliness ⇒ [page 208](#).

Oil pump, oil sump - assembly overview ⇒ [page 147](#).

Removing and installing sump ⇒ [page 149](#).

2.1 Assembly overview - oil pump, sump

Assembly overview - oil filter bracket and oil cooler
⇒ [page 152](#).

1 - 15 Nm

2 - Sealing flange

- With oil seal
- Must be positioned on dowel sleeves.
- Removing and installing ⇒ [page 88](#).
- Install with silicone sealant -D 176 404 A2-.
- Do not additionally oil or grease the oil seal sealing lip.
- Before installing, remove oil residue from crankshaft journal using a clean cloth.

3 - Chain tensioner with tensioning rail, 15 Nm

- When installing, pretension spring and fit

4 - Oil dipstick

- The oil level must not be above the max. mark!
- Markings ⇒ [page 146](#)

5 - Dipstick guide

6 - Guide tube

7 - Dowel sleeves

8 - O-ring

- Renew.

9 - 15 Nm

10 - Suction hose

- Clean strainer if soiled

11 - Baffle plate

12 - 15 Nm

13 - 15 Nm

14 - Sump

- Removing and installing ⇒ [page 149](#).

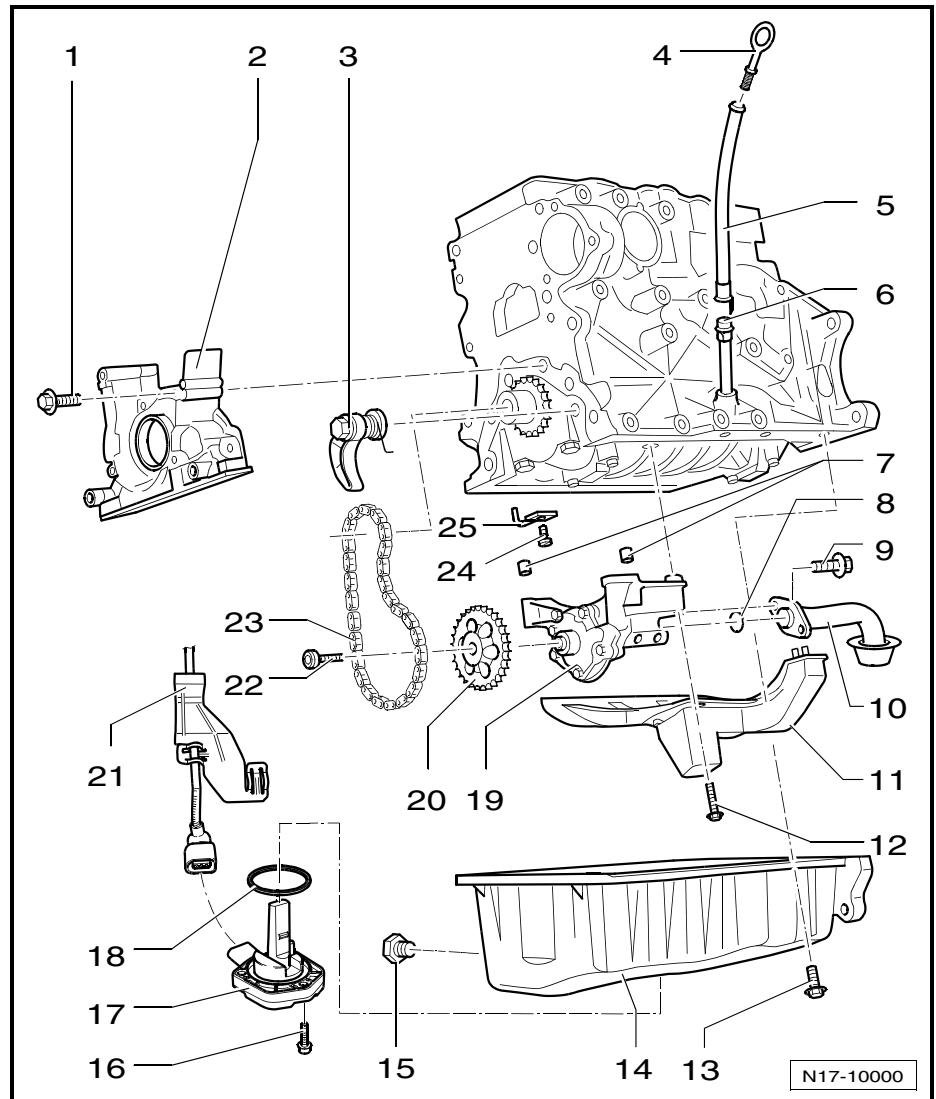



- Clean sealing surface before fitting.
- Install with silicone sealant D 176 404 A2
- 15- Oil drain plug, 30 Nm**
 - Renew.
- 16- 10 Nm**
- 17- Oil level and oil temperature sender -G266-**
 - Black connector, 3-pin.
- 18- Seal**
 - Renew.
- 19- Oil pump**
 - With 12 bar pressure relief valve.
 - Before installing, check that the two dowel sleeves for centring oil pump/cylinder block are fitted
 - Check oil pump for ease of movement.
 - Renew if tight/binding.
- 20- Oil pump chain sprocket**
- 21- Bracket**
 - For oil level and oil temperature sender -G266- wiring harness (if fitted).
- 22- 20 Nm + 1/4 turn (90 °) further**
- 23- Chain**
- 24- 25 Nm**
 - Insert without sealant
- 25- Oil spray jet**
 - For piston cooling ⇒ Fig..

Oil spray jet and pressure relief valve

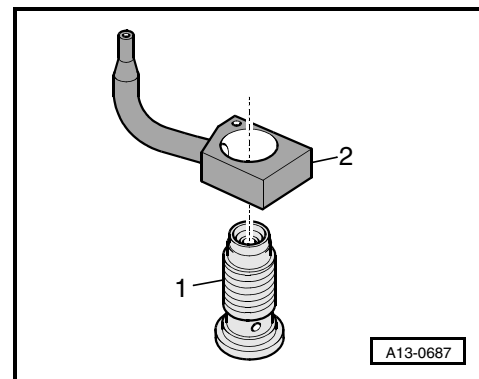



Removing and installing oil level and oil temperature sender -G266- (if fitted)

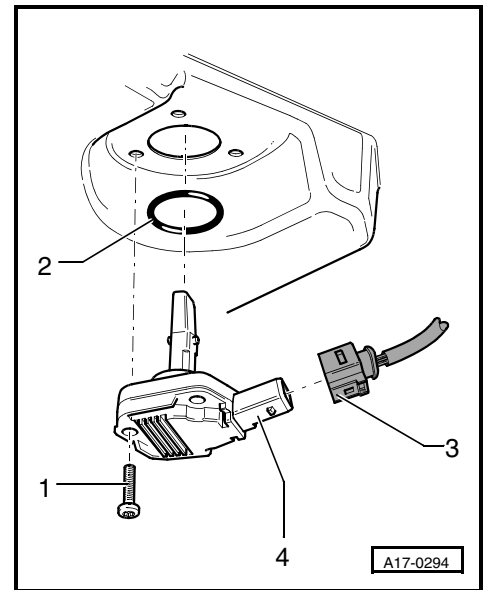

- 1 - Bolt, 10 Nm (self-locking); renew
- 2 - Seal; renew
- 3 - Electrical connector
- 4 - Oil level and oil temperature sender -G266-



2.2 Removing and installing sump

Special tools and workshop equipment required

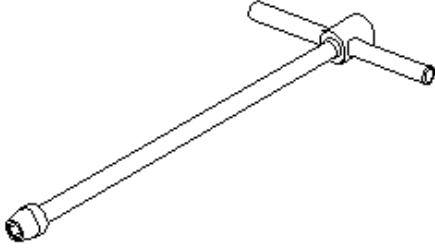
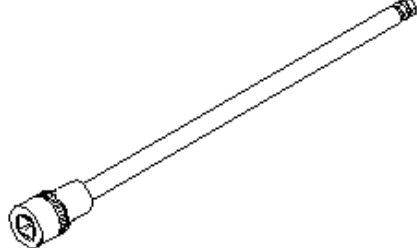
- ◆ 10 mm jointed spanner -VAS 3185-
- ◆ Allen key, long reach -T10058-
- ◆ Torque wrench (5...50 Nm) -V.A.G 1331-
- ◆ Used oil collection and extraction unit -V.A.G 1782-

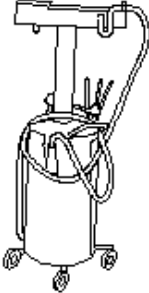
<p>3185</p> 	<p>T10058</p> 
<p>V.A.G 1331</p> 	<p>V.A.G 1782</p> 
<p style="text-align: right;">W17-10009</p>	



- ◆ Silicone sealant -D176404A2-
- ◆ Hand drill with plastic brush
- ◆ Safety goggles
- ◆ Flat scraper

Removing ⇒ page 150.

Installing ⇒ page 150.

2.2.1 Removing

- Drain engine oil.



Note

Observe environmental regulations for disposal.

- Pull 3-pin connector off oil level and oil temperature sender -G266- (if fitted).
- Remove sump.
- Loosen sump with light blows of a rubber headed hammer if necessary.
- Remove sealant residue on cylinder block with a flat scraper.



WARNING!

Wear eye protection.

- Remove sealant residue on sump with a rotating brush, e.g. a hand drill with a plastic brush.
- Clean sealing surfaces. They must be free of oil and grease.

2.2.2 Installing



Note

- ◆ Note the expiry date of the sealant.
- ◆ Install sump within 5 minutes of applying silicone sealant.
- Cut off tube nozzle at forward marking (approx. 3 mm nozzle Ø).
- Apply silicone sealant, as shown, to clean sump sealing surface. Sealant bead must be:
 - ◆ 2...3 mm thick.
 - ◆ Run bead along inner side of bolt holes -arrows-.



Note

The sealant bead must not be thicker, or excess sealant may enter the oil sump and block the strainer in the oil suction pipe.

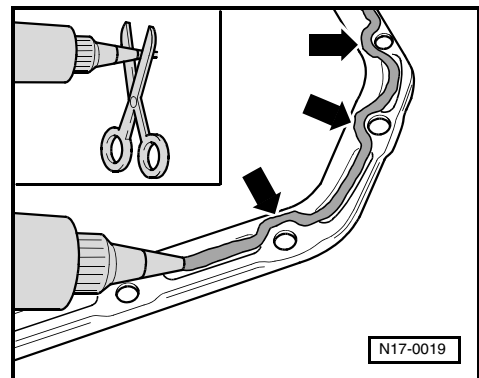
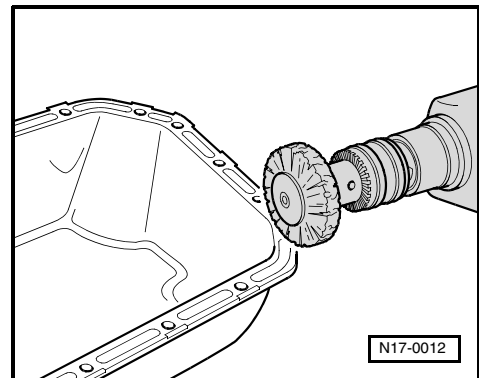



- Apply silicone sealant to clean sealing surface of sump as shown in figure. (The figure shows the position of the sealant bead on the cylinder block.)
- Install sump immediately and tighten all sump bolts lightly.

i **Note**

When installing sump with engine out of vehicle, ensure that sump is flush with cylinder block at flywheel end.

- Tighten oil sump bolts to 15 Nm.
- Tighten sump/gearbox bolts to 45 Nm.

i **Note**

Allow sealant to dry for approx. 30 minutes after installing sump. Only then fill with engine oil.

Further assembly is basically the reverse of the dismantling sequence.

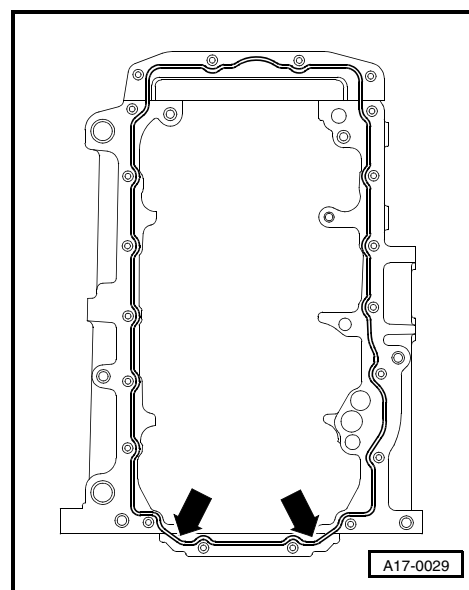

3 Oil filter bracket, oil pressure and oil cooler

! **Caution!**

Finding metal shavings or a large quantity of small metal particles during engine repair could indicate that the crankshaft bearings or conrod bearings are damaged. To prevent this from causing further damage, perform the following repairs:

Thoroughly clean oil passages,

Renew oil spray jets,

Renew oil cooler,

Renew oil filter element.

i **Note**

Before carrying out repair work, secure engine on engine and gearbox support -VAS 6095- using universal mounting -VAS 6095/1-.

Observe safety precautions ⇒ [page 208](#).

Observe rules for cleanliness ⇒ [page 208](#).

Assembly overview - oil filter bracket and oil cooler
⇒ [page 152](#).

Checking oil pressure and oil pressure switch -F1-
⇒ [page 153](#).



3.1 Assembly overview - oil filter bracket and oil cooler

- 1 - Gasket**
 Renew.
- 2 - 15 Nm + 1/4 turn (90 °) further**
 Renew.
 First fit upper left and lower right bolts and then tighten all four bolts diagonally
- 3 - Oil filter bracket**
- 4 - Seal**
 Renew.
- 5 - Pipe union, 30 Nm**
- 6 - Oil supply line, 22 Nm**
 To turbocharger
- 7 - Oil pressure switch -F1-, 22 Nm**
 0.7 bar switch: Brown
 If oil seal is leaking, nip open and renew.
 Checking ⇒ [page 153](#), Checking oil pressure and oil pressure switch.
- 8 - Cap, 25 Nm**
 Loosen and tighten with socket 36 mm -T10125-.
- 9 - O-ring**
 Renew.
- 10 - Oil filter element**
 Observe change intervals
 Note installation position: top
- 11 - Seal**
 Renew.
 Oil before installing.
 Clipped into lugs on oil cooler.
- 12 - Oil cooler**
 Ensure clearance to adjacent components.
 Checking oil cooler for leaks ⇒ [page 170](#)
- 13 - Seal**
 Renew.
- 14 - Cap, 25 Nm**
 Loosen and tighten with socket 36 mm -T10125-.
- 15 - 10 Nm**
- 16 - Bracket**

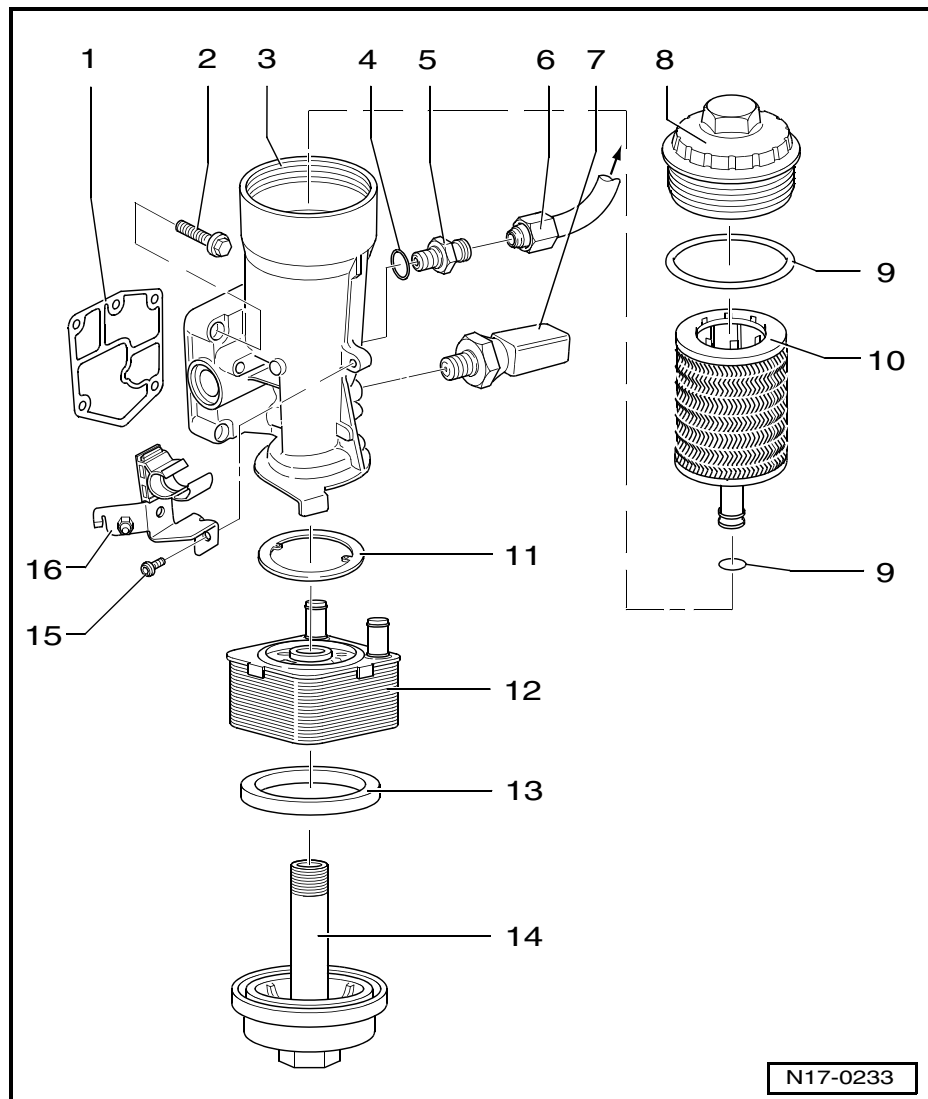



3.2 Checking oil pressure and oil pressure switch -F1-

Special tools and workshop equipment required

- ◆ Oil pressure tester -V.A.G 1342-
- ◆ Diode test lamp -V.A.G 1527 B-
- ◆ Adapter set -V.A.G 1594 A-

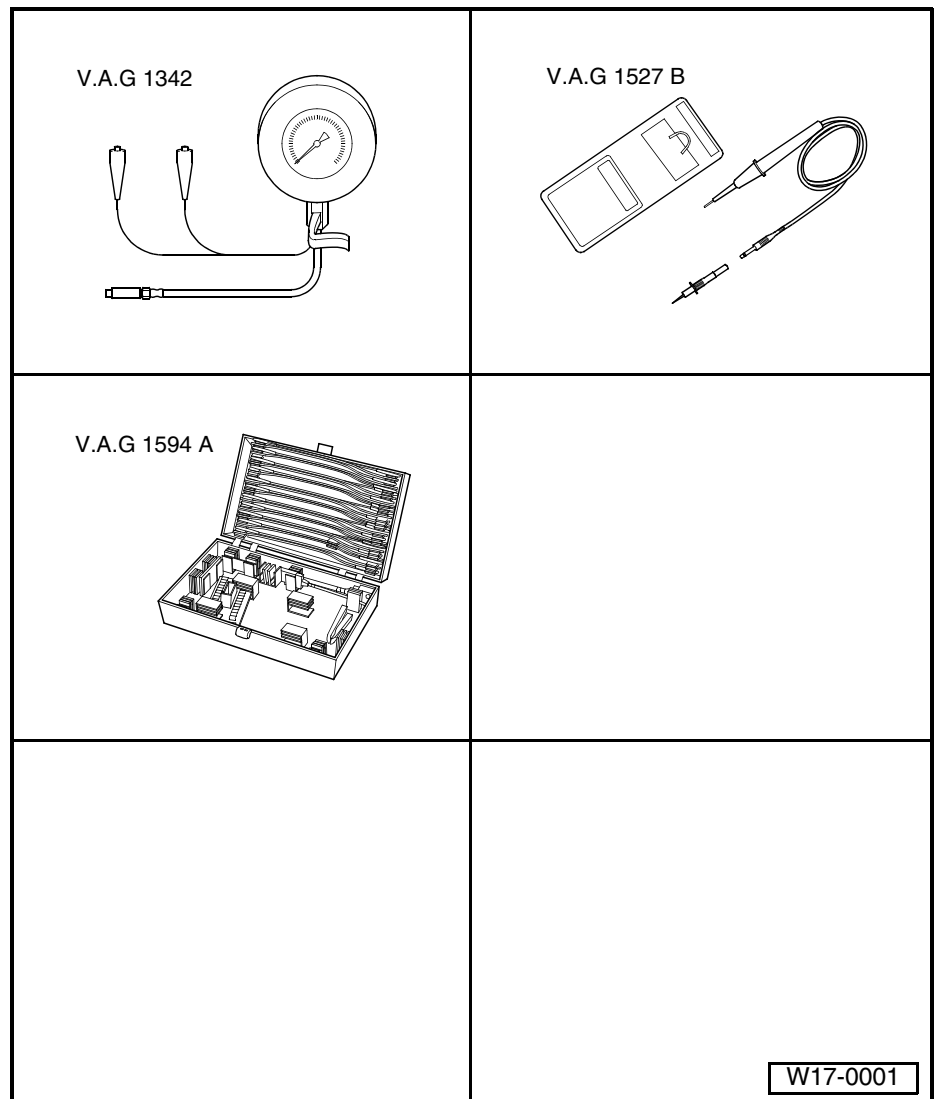

Test procedure



Note

Functional check and repair of the optical oil pressure gauge:
⇒ [page 305](#), Current flow diagrams.

- Remove oil pressure switch -F1- and screw into oil pressure tester.
- Screw oil pressure tester into oil filter bracket in place of oil pressure switch.
- Connect brown wire of oil pressure tester to earth (-).
- Connect diode tester -V.A.G 1527 B- to battery positive (+) and oil pressure switch using cables from auxiliary test set -V.A.G 1594 A-. LED must not light up.

If the LED lights up:

- Renew oil pressure switch -F1- ⇒ [item 7 on page 152](#).

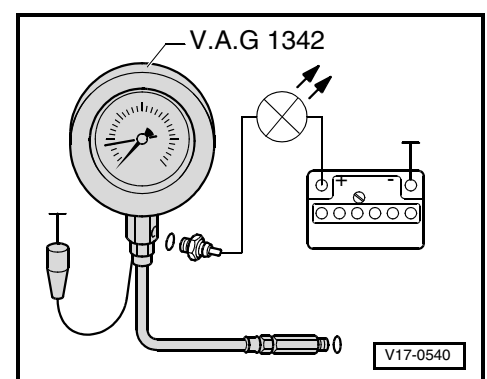



If LED does not light up:

- Start engine and increase revs. slowly. At 0.55...0.85 bar the LED must light up, otherwise renew oil pressure switch -F1-.

Checking oil pressure

- Increase engine speed further. At 2000 rpm and an oil temperature of 80 °C, the oil pressure should be at least 2.0 bar.

If the specifications are not attained

- Rectify mechanical damage, e.g. damaged bearings.
- Renew oil filter bracket with pressure relief valve or renew oil pump.

At higher engine speeds, the oil pressure must not exceed 7.0 bar.

If the specification is exceeded:

- Check oil channels.
- If necessary, renew oil filter bracket with pressure relief valve.



19 – Cooling

1 Removing and installing parts of cooling system

WARNING!

Due to the cramped conditions, note the following when carrying out repairs:

- ◆ *Route all the various lines (e.g. for fuel, hydraulics, activated charcoal filter system, coolant, refrigerant, brake fluid and vacuum) and electrical wiring in their original positions.*
- ◆ *Ensure that there is sufficient clearance to all moving or hot components.*

Note

- ◆ *Hoses are secured with spring-type clips. In case of repair, only use spring-type clips.*
- ◆ *Spring-type clip pliers -VAS 5024- are recommended for installation of spring-type clips.*
- ◆ *When the engine is warm, the cooling system is under pressure. If necessary, release pressure before beginning repair work.*
- ◆ *When installing coolant hoses, route stress-free so that they do not come into contact with other components (observe markings on coolant connection and hose).*
- ◆ *Perform cooling system leakage test with cooling system tester -V.A.G 1274- and adapters -V.A.G 1274/8- and -V.A.G 1274/9- ⇒ [page 168](#).*

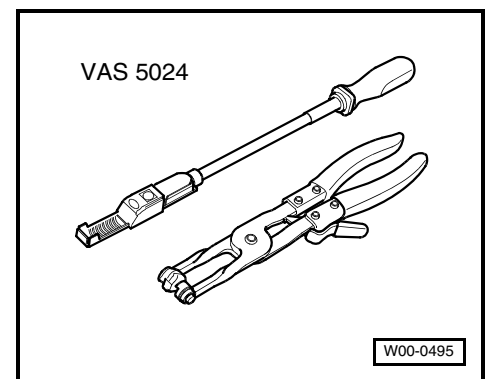

Parts of cooling system - engine side ⇒ [page 156](#).

Coolant hose schematic diagram ⇒ [page 157](#).

Draining and filling cooling system ⇒ [page 159](#).

Coolant mixture ratios ⇒ [page 159](#), Draining and filling with coolant.

Removing and installing coolant pump ⇒ [page 162](#).

Removing and installing thermostat ⇒ [page 164](#).

Removing and installing 4/2-way valve with thermostat ⇒ [page 166](#).

Checking cooling system for leaks ⇒ [page 168](#).

Checking oil cooler for leaks ⇒ [page 170](#).



1.1 Parts of cooling system - engine side

- 1 - Grommet
 - Not supplied separately
- 2 - Sleeve
 - Not supplied separately
- 3 - 2.7 Nm
- 4 - 40 Nm
- 5 - Bracket
 - For coolant circulation pump 2 -V178- (if fitted).
- 6 - Front coolant pipe
 - Coolant hose schematic diagram ⇒ [page 157](#).
- 7 - O-ring
 - Renew.
- 8 - Right coolant pipe
 - Coolant hose schematic diagram ⇒ [page 157](#).
- 9 - O-ring
 - Renew.
- 10 - Coolant temperature sender at radiator outlet -G83- (if fitted)
- 11 - Securing clip
- 12 - 9 Nm
- 13 - 9 Nm
- 14 - 9 Nm
- 15 - Coolant line
 - Coolant hose schematic diagram ⇒ [page 157](#).
- 16 - 9 Nm
- 17 - Gasket
 - Renew.
- 18 - Connection
 - Coolant hose schematic diagram ⇒ [page 157](#).
- 19 - 9 Nm
- 20 - Securing clip
- 21 - Coolant temperature sender -G62-
 - For engine control unit -J623-.
 - If necessary, release pressure in cooling system before removing
 - Checking ⇒ [page 249](#).
- 22 - O-ring
 - Renew.
- 23 - Centre hex stud, 9 Nm
 -
- 24 - 9 Nm

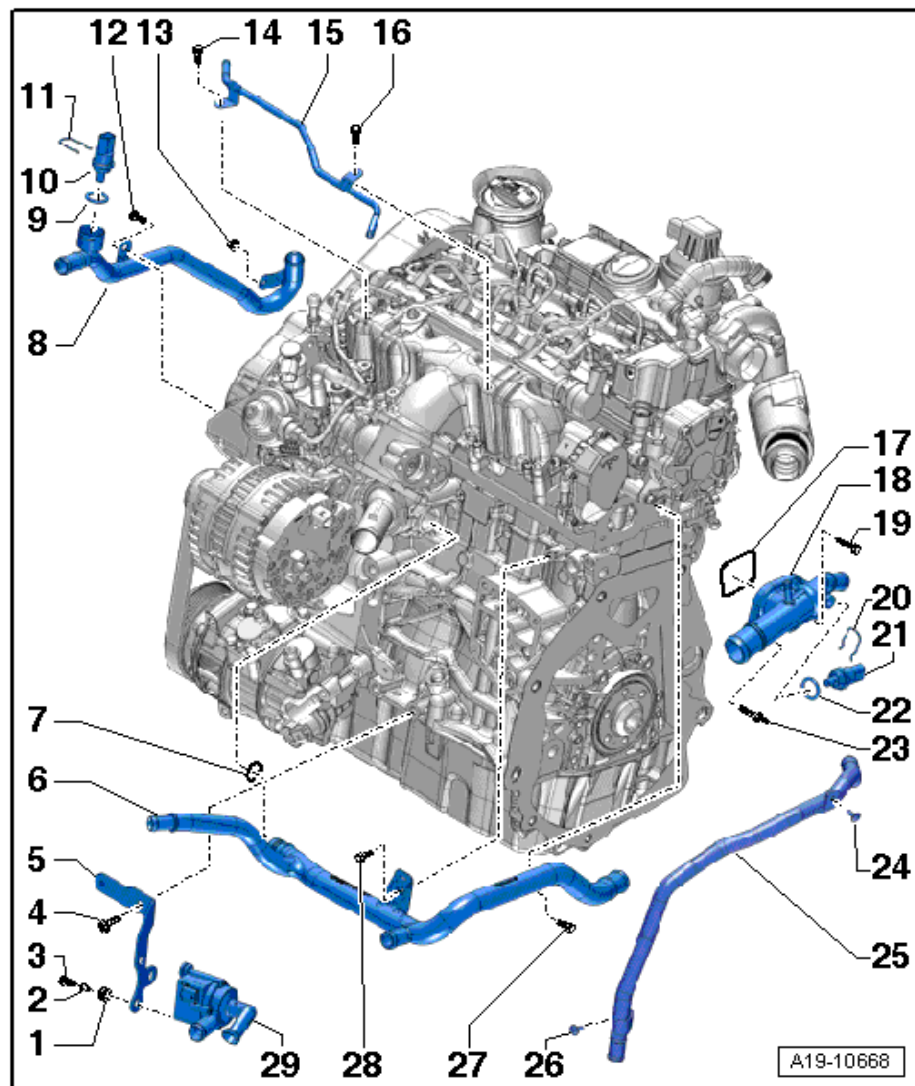



25 - Left coolant pipe

Coolant hose schematic diagram ⇒ [page 157](#).

26 - 9 Nm

27 - 40 Nm

28 - 13 Nm

29 - Coolant circulation pump 2 -V178- (if fitted)

Coolant hose schematic diagram ⇒ [page 157](#).

1.2 Coolant hose schematic diagram diagram

Coolant hose schematic diagram (vehicles with no 4/2-way valve) ⇒ [page 157](#).

Coolant hose schematic diagram (vehicles with 4/2-way valve) ⇒ [page 158](#).

1.2.1 Coolant hose schematic diagram (vehicles with no 4/2-way valve)

- 1 - Expansion tank
- 2 - Radiator
 - For exhaust gas re-circulation.
- 3 - Heat exchanger for heater
- 4 - Cylinder head/cylinder block
- 5 - Engine oil cooler
- 6 - Coolant circulation pump -V178- (if fitted)
- 7 - Upper coolant hose
- 8 - Radiator
- 9 - Lower coolant hose
- 10 - Coolant pump and thermostat
- 11 - Auxiliary heater

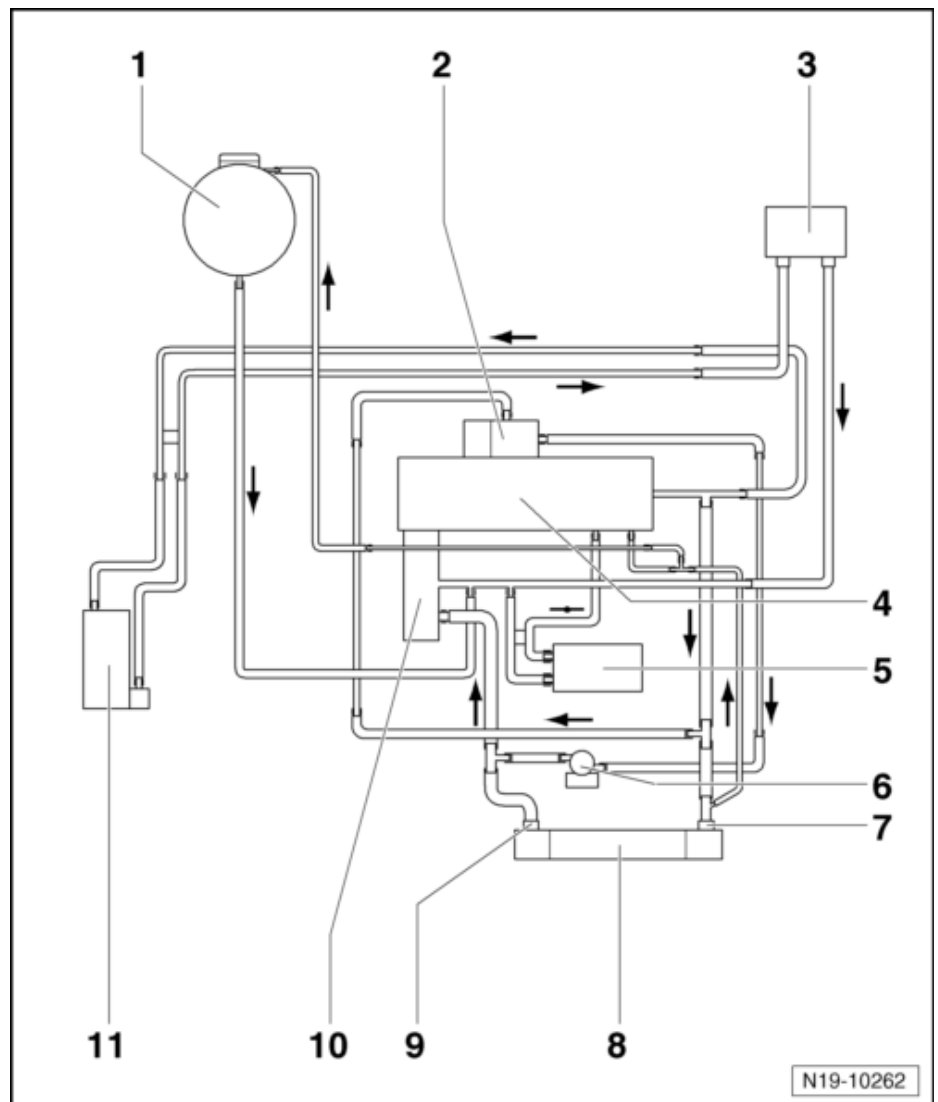



1.2.2 Coolant hose schematic diagram (vehicles with 4/2-way valve)

- 1 - Radiator
- 2 - Coolant circulation pump -V178-
- 3 - Engine oil cooler
- 4 - 4/2-way valve
 - With thermostat
 - Removing and installing
 - ⇒ page 166.
- 5 - Coolant pump
- 6 - Cylinder head/cylinder block
- 7 - Expansion tank
- 8 - Radiator
 - For exhaust gas recirculation.
- 9 - Supplementary heater/auxiliary heater
 - Depending on equipment.
- 10 - Circulation pump -V55-
 - Depending on equipment.
- 11 - Heat exchanger for heater
 - With quick-release coupling
- 12 - Gearbox oil cooler
 - Only vehicles with dual clutch gearbox/automatic gearbox.

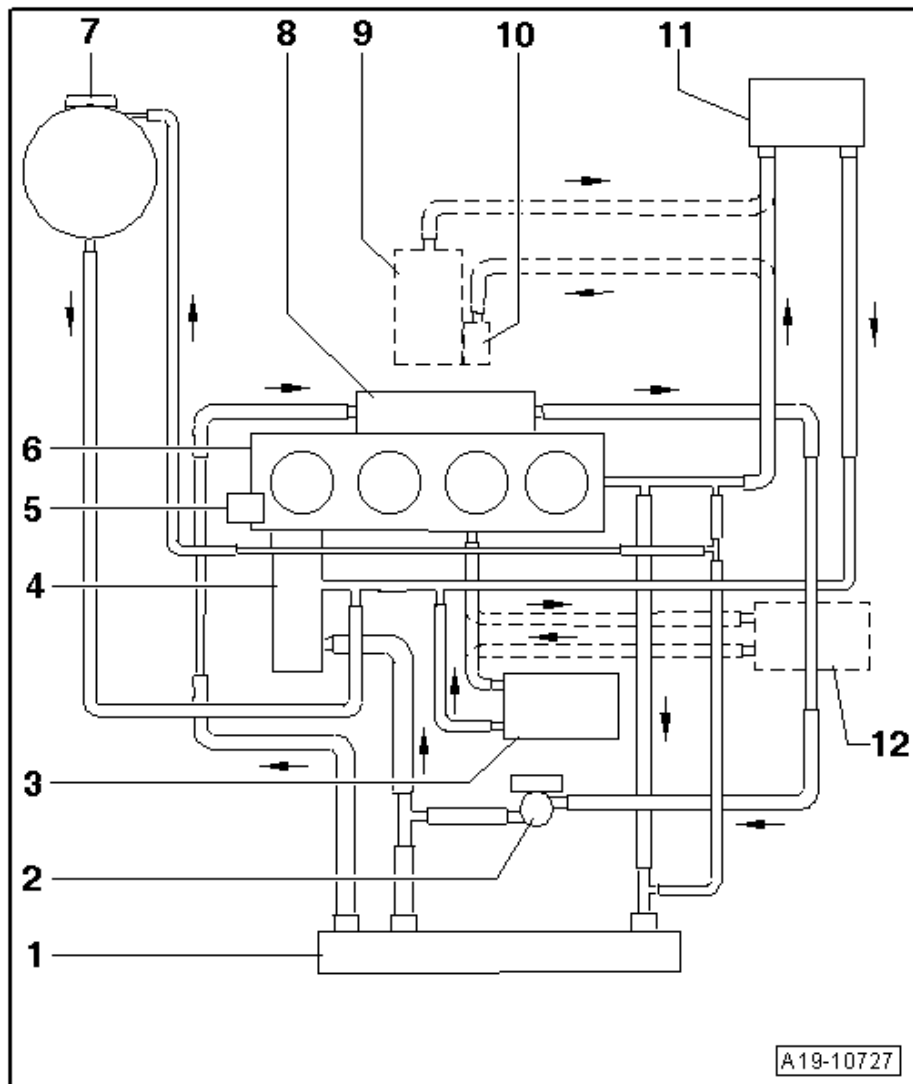





1.3 Draining and filling coolant

Special tools and workshop equipment required

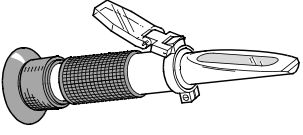
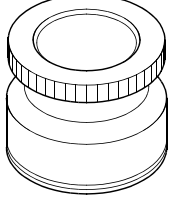
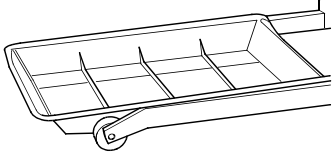
- ◆ Refractometer -T10007-
- ◆ Adapter -V.A.G 1274/8-
- ◆ Drip tray -V.A.G 1306-
or drip tray -VAS 6208-
- ◆ Torque wrench (5...50 Nm) -V.A.G 1331-
- ◆ Spring-type clip pliers -VAS 5024-

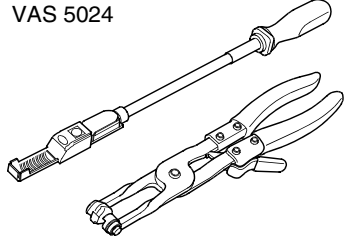
<p>T10007</p> 	<p>V.A.G 1274/8</p> 
<p>V.A.G 1306</p> 	<p>V.A.G 1331</p> 
<p>VAS 5024</p> 	<p>W19-0038</p>

Not illustrated:

- ◆ Cooling system charge unit -VAS 6096 -
- ◆ Coolant additive -G 12-, according to TL "VW 774 F"

Draining ⇒ [page 159](#).

Filling ⇒ [page 160](#).

1.3.1 Draining

- Open cap on coolant expansion tank.



WARNING!

*Hot steam may escape when expansion tank is opened.
Place rag over cap and open with caution.*



- Pull lower coolant hose off radiator using, for example, assembly tool for spring type clips -VAS 5024-.
- To drain coolant from engine, also remove coolant hose from oil cooler -arrow-.

i Note

Follow disposal regulations for coolant!

1.3.2 Filling

! Caution!

For mixing only tap water must be used. Well water does not have the required quality to ensure the coolant's function.

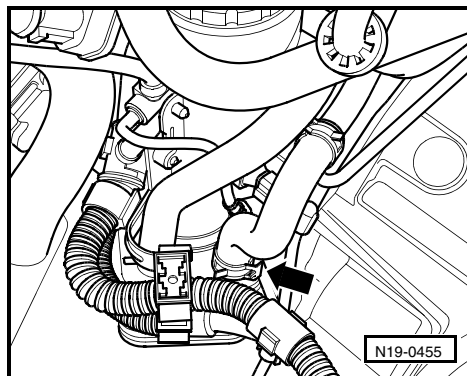

i Note

- ♦ Only use coolant additive -G 12- in accordance with TL "VW 774 F". Identification characteristics: Coloured lilac (purple)
- ♦ Coolant additive -G 12- purple (in accordance with TL "VW 774 F") can be mixed with the previous coolant additive -G 12- red!
- ♦ Coolant additive -G 12- and coolant additives marked "In accordance with TL VW 774 F" prevent frost and corrosion damage, scaling and also raise the boiling point of coolant. Therefore, the cooling system must be filled all year round with frost and corrosion protection additives.
- ♦ Because of its high boiling point, the coolant improves engine reliability under heavy loads, particularly in countries with tropical climates.
- ♦ Frost protection is required down to about -25 °C (in countries with arctic climates: down to about -35 °C).
- ♦ The coolant concentration must not be reduced by adding water even in warmer seasons and in warmer countries. The coolant additive must be at least 40 % of mixture.
- ♦ If for climatic reasons greater frost protection is required, the amount of -G 12- can be increased, but only up to 60% (frost protection to about -40 °C). Otherwise frost protection and cooling effectiveness are reduced again.
- ♦ The refractometer -T10007- is recommended for determining the current anti-freeze density.
- ♦ If radiator, heat exchanger, cylinder head or cylinder head gasket is replaced, do not reuse old coolant.

Recommended mixture ratios

Frost protection to	Anti-freeze proportion	-G 12- ¹⁾	Water ¹⁾
-25 °C	40 %	3.2 l	4.8 l
-35 °C	50 %	4.0 l	4.0 l

¹⁾ The quantity of coolant can vary depending on equipment.

- Secure lower coolant hose to radiator union.



- Connect coolant hose -arrow- to oil cooler.

With cooling system charge unit -VAS 6096-

- Screw adapter -V.A.G 1274/8- onto expansion tank.
- Fill coolant circuit using cooling system charge unit -VAS 6096- ⇒ operating instructions for cooling system charge unit -VAS 6096-.

Without cooling system charge unit -VAS 6096-

- Fill with coolant slowly up to max. mark on expansion tank.

With or without cooling system charge unit -VAS 6096-

- Fit expansion tank cap.
- Start engine and maintain an engine speed of about 2000 rpm for about 3 minutes.
- Run engine until radiator fan cuts in.

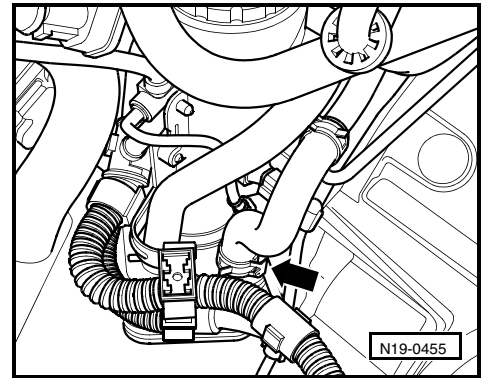

! WARNING!

***Hot steam may escape when expansion tank is opened.
Place cloth over cap and open with caution.***



- Check coolant level and top up if necessary. When the engine is at normal operating temperature, the coolant level must be on the MAX mark; when the engine is cold, between the MIN and MAX marks.



1.4 Removing and installing coolant pump

Special tools and workshop equipment required

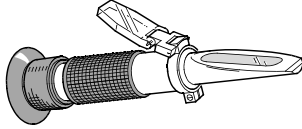
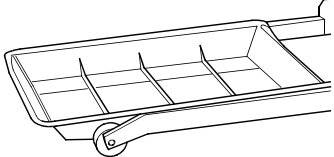
- ◆ Refractometer -T10007-
- ◆ Drip tray -V.A.G 1306- or drip tray -VAS 6208-
- ◆ Torque wrench (5...50 Nm) -V.A.G 1331-
- ◆ Spring-type clip pliers -VAS 5024-

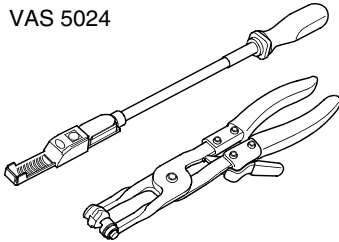
<p>T10007</p> 	<p>V.A.G 1306</p> 
<p>V.A.G 1331</p> 	<p>VAS 5024</p> 
	<p>W19-0019</p>

Removing ⇒ [page 162](#).

Installing ⇒ [page 163](#).

1.4.1 Removing

Note

Always renew gaskets, seals and O-rings.

- Drain coolant ⇒ [page 159](#).
- Remove poly V-belt ⇒ [page 76](#).
- Remove toothed belt ⇒ [page 117](#), Removing, installing and tensioning toothed belt.



- Remove securing bolts -1- for coolant pump -2- and carefully remove coolant pump.

1.4.2 Installing

Installation is carried out in the reverse order. When installing, note the following:

- Moisten new O-ring -3- with coolant.
- Insert coolant pump -2- in cylinder block and tighten securing bolts -1- to 15 Nm.

Note

The coolant pump plug faces downwards.

- Install and tension toothed belt ⇒ [page 117](#).
- Install poly V-belt ⇒ [page 76](#).
- Fill with coolant ⇒ [page 159](#).

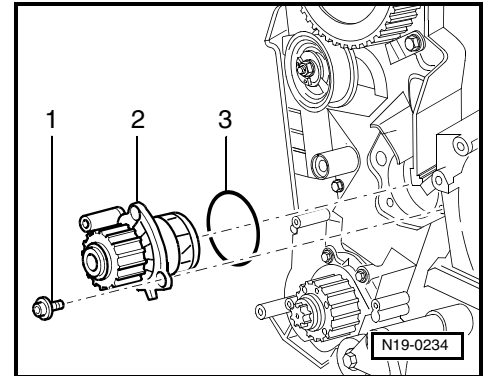
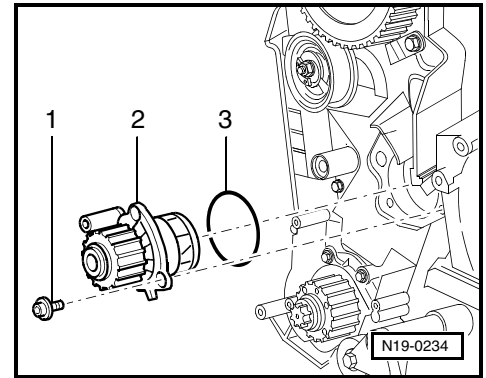





1.5 Removing and installing thermostat

Special tools and workshop equipment required

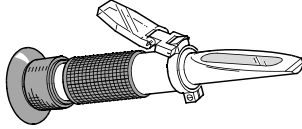
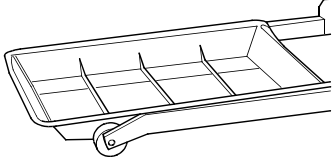
- ◆ Refractometer -T10007-
- ◆ Drip tray -V.A.G 1306- or drip tray -VAS 6208-
- ◆ Torque wrench (5...50 Nm) -V.A.G 1331-
- ◆ Spring-type clip pliers -VAS 5024-

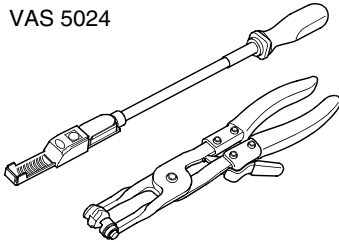
<p>T10007</p> 	<p>V.A.G 1306</p> 
<p>V.A.G 1331</p> 	<p>VAS 5024</p> 
	<p>W19-0019</p>

Removing ⇒ [page 164](#).

Installing ⇒ [page 165](#).

1.5.1 Removing



Note

Always renew gaskets, seals and O-rings.

- Drain coolant ⇒ [page 159](#).
- Remove throttle valve module -J338- ⇒ [page 209](#).
- Pull coolant hose off connection.



- Loosen securing bolts -4- of union -3- using T-bar and 10 mm socket -3185- and remove using Allen key, long reach -T10058- and remove union -3- together with thermostat -1-.
- Turn thermostat -1- 90° anticlockwise and remove from union -3-.

1.5.2 Installing

Installation is carried out in the reverse order. When installing, note the following:

- Moisten new O-ring -2- with coolant.
- Insert thermostat -1- into union -3- and turn 90° clockwise.

Note

The brace on the thermostat must be almost vertical.

- Fit connection -3- with thermostat -1- into cylinder block.
- Tighten securing bolts -4- using T-bar and 10 mm socket -3185-. Specified torque: 15 Nm
- Install throttle valve module -J338- ⇒ [page 209](#).
- Fill with coolant ⇒ [page 159](#).

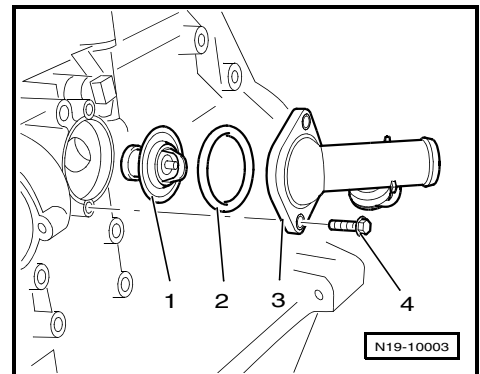
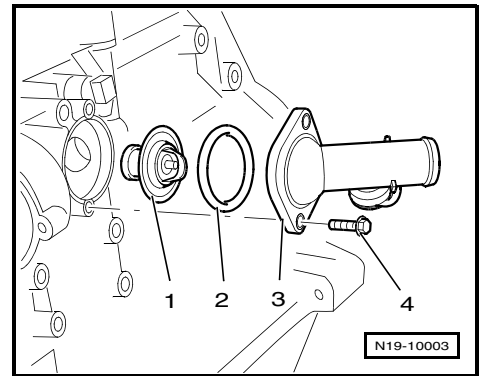





1.6 Removing and installing 4/2-way valve with thermostat

Special tools and workshop equipment required

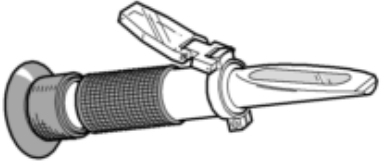
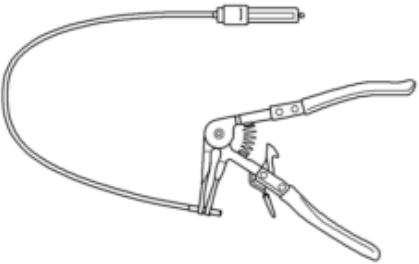
- ◆ Refractometer -T10007-
- ◆ Hose clip pliers -VAS 6340-
- ◆ Torque wrench (5...50 Nm) -V.A.G 1331-

<p>T10007</p> 	<p>VAS 6340</p> 
<p>V.A.G 1331</p> 	
	<p>W19-10020</p>

Removing



Note

The thermostat is located within the 4/2-way valve and cannot be replaced individually.

- Drain coolant ⇒ [page 159](#).
- Remove alternator ⇒ starter, current supply, CCS; Rep. Gr. 27; Removing and installing alternator.
- Remove throttle valve module -J338- ⇒ [page 209](#).
- Pull coolant hoses off unions -A, B and D-.



- Pull coolant pipe out of union -C-.
- Unscrew securing bolts -3- for 4/2-way valve -2-.
- Pull valve out of cylinder block and then to the left to subsequently separate connection -C- from coolant pipe.

Installing



Note

Renew gaskets and seals.

- First seat 2-way valve with connection -C- on coolant pipe then insert into cylinder block.
- Insert securing bolts -3- and tighten to 15 Nm.
- Connect coolant hoses as follows:
 - ◆ -A-: Bypass line to cylinder head
 - ◆ -B-: Expansion tank
 - ◆ -D-: Coolant return line
- Filling cooling system ⇒ [page 159](#).
- Install throttle valve module -J338- ⇒ [page 209](#).
- Install alternator ⇒ starter, current supply, CCS; Rep. Gr. 27; Removing and installing alternator.

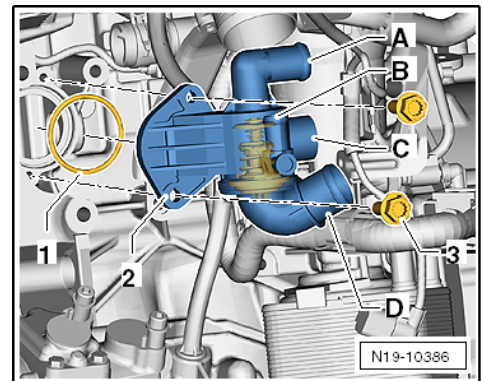
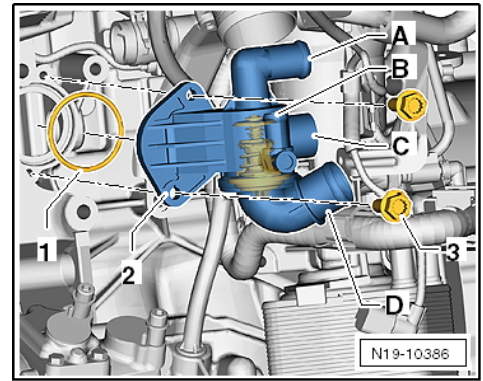



1.7 Checking cooling system for leaks

Special tools and workshop equipment required

- ◆ Cooling system tester -V.A.G 1274-
- ◆ Adapter for cooling system tester -V.A.G 1274/8-
- ◆ Adapter for cooling system tester -V.A.G 1274/9-

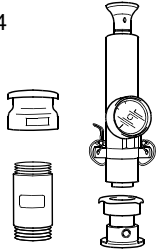
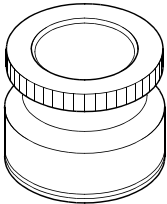
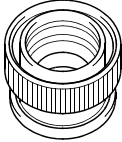
<p>V.A.G 1274</p> 	<p>V.A.G 1274/8</p> 
<p>V.A.G 1274/9</p> 	
	<p>G19-0002</p>

Test prerequisite

- Engine at operating temperature.

Test procedure

- Open cap on coolant expansion tank.



WARNING!

**Hot steam may escape when expansion tank is opened.
Place rag over cap and open with caution.**

- Attach cooling system tester -V.A.G 1274- with cooling system tester adapter -V.A.G 1274/8- to expansion tank.
- Use hand pump on tester to create a pressure of about 1.0 bar.

If pressure drops:



- Find leaks and rectify.
- Check coolant level, if necessary replenish coolant
⇒ page 159.

1.7.1 Checking pressure relief valve in filler cap

- Attach cooling system tester -V.A.G 1274- with cooling system tester adapter -V.A.G 1274/9- to cap.
- Operate hand pump.
- Use hand pump on cooling system tester to create a pressure of approx. 1.6 bar.

The pressure relief valve must not open.

If the pressure relief valve opens prematurely:

- Renew sealing cap.
- Increase pressure to above 1.6 bar.

The pressure relief valve must open.

If the pressure relief valve does not open:

- Renew sealing cap.

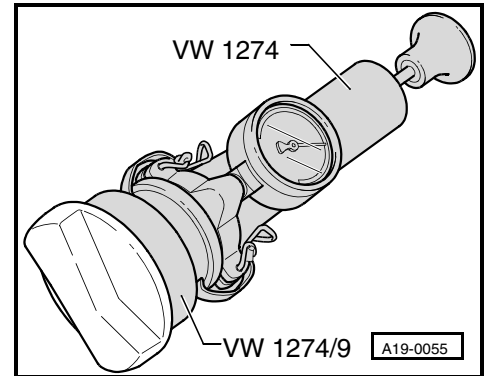



1.8 Checking oil cooler for leaks

Special tools and workshop equipment required

- ◆ Refractometer -T10007-
- ◆ Hose clamps, up to Ø 25 mm -3094-
- ◆ Cooling system tester -V.A.G 1274-
- ◆ Adapter for cooling system tester -V.A.G 1274/8-
- ◆ Spring-type clip pliers -VAS 5024 A-
- ◆ Drip tray -V.A.G 1306- or drip tray -VAS 6208-

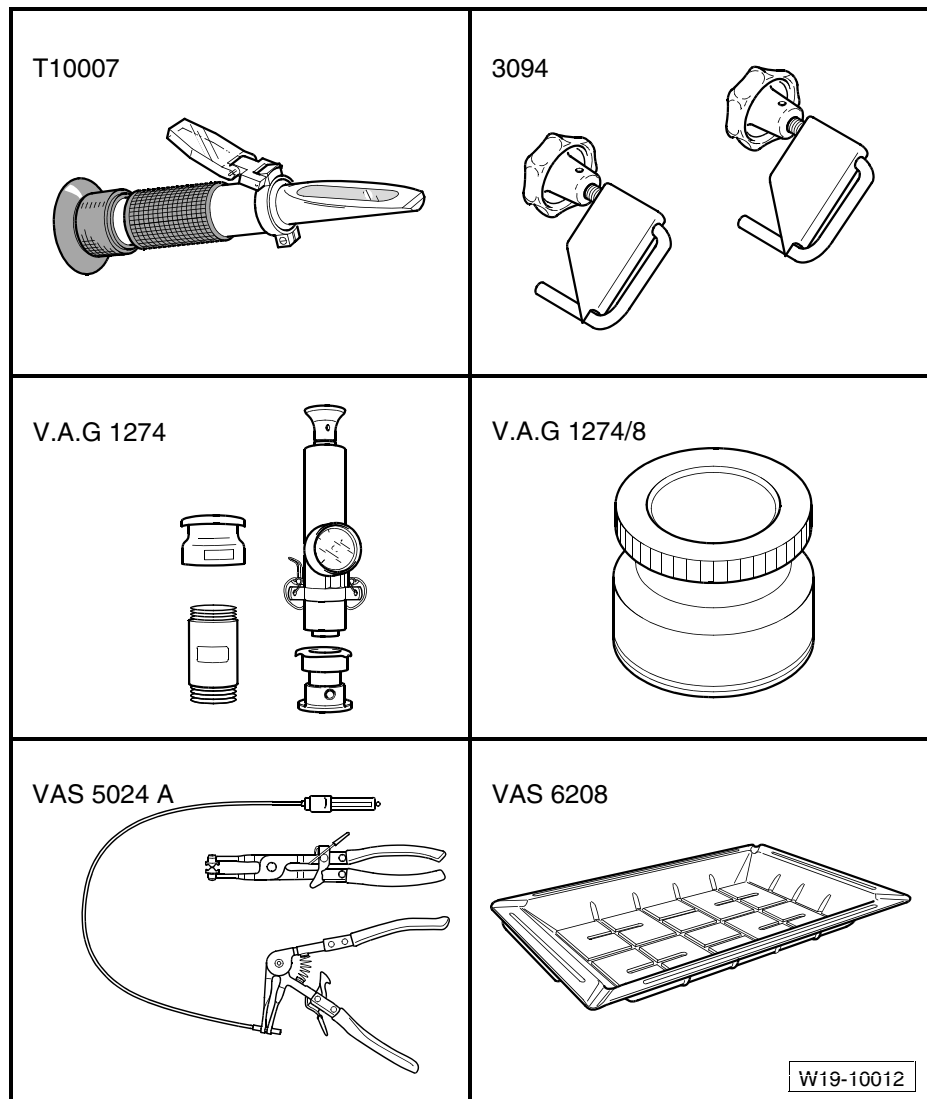

Not illustrated:

- ◆ Torque wrench (5...50 Nm) -V.A.G 1331-
- ◆ Expansion tank
-1K0 121 407 A bzw. 6Q0 121 407 A bzw. 1J0 121 407 B-
- ◆ Plug -191 211 343-
- ◆ Cap -1J0 121 324-
- ◆ Coolant hose -251 265 056-

Conditions

- Engine cold

Test procedure



- Clamp supply and return lines off oil cooler using hose clamps to Ø 25 mm -VAS 3094-.
- Loosen hose clamps -arrows- using spring type clip pliers -VAS 5024-.

i Note

Collect escaping coolant with drip tray -V.A.G 1306- or drip tray -VAS 6208-.

- Pull coolant hoses off oil cooler.
- Slide sealing cap -5- to rear connection of oil cooler -4-.
- Secure sealing plug -2- to breather connection of expansion tank -1-.
- Secure coolant hose -3- to oil cooler and expansion tank.
- Fill expansion tank up to max. marking.
- Attach cooling system tester -V.A.G 1274- with cooling system tester adapter -V.A.G 1274/8- to expansion tank.
- Use hand pump on tester to create a pressure of about 1.6 bar.
- Observe drop in pressure on gauge. A pressure drop within 10 minutes is not permitted.

If pressure drops:

- Renew oil cooler ⇒ [page 152](#), Assembly overview - oil filter bracket and oil cooler

Installation is carried out in the reverse order. When installing, note the following:

- Check coolant level, if necessary replenish coolant ⇒ [page 159](#).

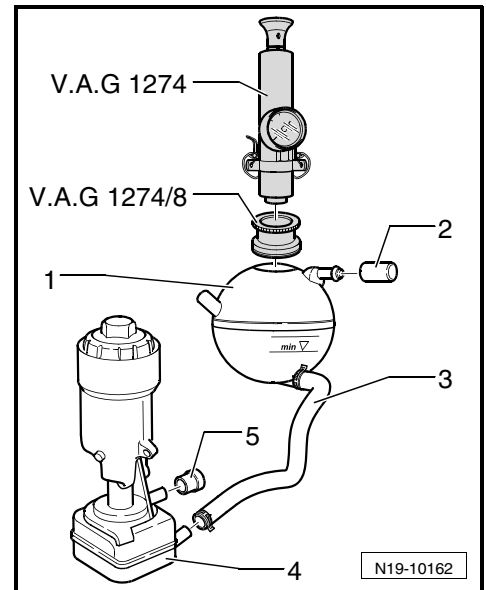
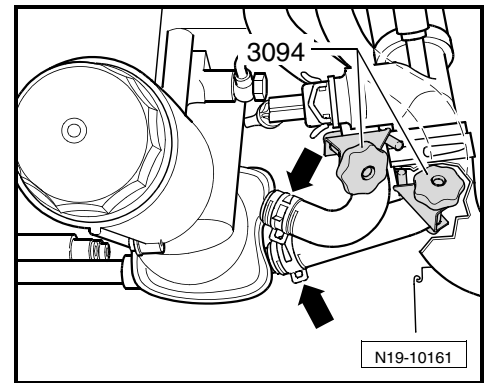



20 – Fuel supply system

1 Removing and installing parts of fuel supply system

Note

- ◆ *Hose connections are secured with either spring-type or clamp-type clips.*
- ◆ *Always renew clamp-type clips with spring-type clips.*
- ◆ *Fuel hoses on engine must be secured only with spring-type clips. The use of clamp or screw-type clips is not permissible.*
- ◆ *Spring-type clip pliers -VAS 5024- are recommended for installation of spring-type clips.*

Safety precautions when working on fuel supply system
⇒ [page 172](#).

Observe rules for cleanliness ⇒ [page 173](#).

Assembly overview - fuel filter ⇒ [page 173](#)

Removing and installing upper part of fuel filter ⇒ [page 175](#).

Removing and installing supplementary fuel pump -V393- (in-line electronic fuel pump) ⇒ [page 177](#).

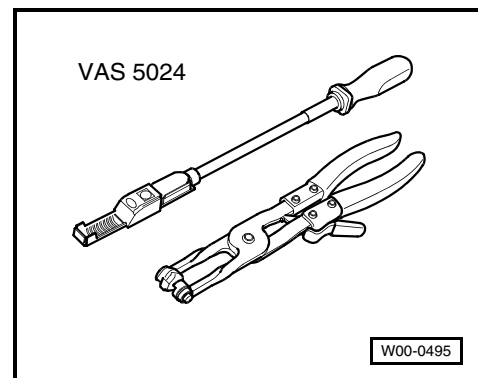

1.1 Safety precautions when working on fuel supply system

WARNING!

Due to the cramped conditions, note the following when carrying out repairs:

- ◆ *Route all the various lines (e.g. for fuel, hydraulics, activated charcoal filter system, coolant, refrigerant, brake fluid and vacuum) and electrical wiring in their original positions.*
- ◆ *Ensure that there is sufficient clearance to all moving or hot components.*
- ◆ *The fuel and the fuel lines in the fuel system can become very hot (danger of scalding)!*
- ◆ *The fuel system is also under pressure! Before opening the system, place cloths around the connections. Then carefully loosen connection to release the pressure!*
- ◆ *Wear eye and hand protection when performing any type of repair work on the fuel system!*

When working on a full or partly full fuel tank, note the following:

- ◆ Before beginning work, place an extraction hose close to installation opening in fuel tank to extract escaping fuel fumes and switch on exhaust extraction system. If no ex-



haust extraction system is available, a radial fan with a displacement greater than 15 m³/h can be used providing that motor is not in air flow.

- ◆ Prevent skin contact with fuel! Wear fuel-resistant gloves!

1.2 Rules for cleanliness

The following "rules" for cleanliness are to be carefully heeded when working on the fuel supply/injection system:

- ◆ Thoroughly clean all unions and adjacent areas before disconnecting.
- ◆ Place removed parts on a clean surface and cover. Use only lint-free cloths!
- ◆ Carefully cover opened components or seal if repairs cannot be carried out immediately.
- ◆ Only install clean components: Only unpack replacement parts immediately prior to installation. Do not use parts that have not been stored in their packing (e.g. in tool boxes etc.).
- ◆ Existing transport and protective packaging and sealing caps must only be removed immediately prior to installation.
- ◆ When system is open: Avoid working with compressed air if possible. Do not move vehicle unless absolutely necessary.
- ◆ Also ensure that no diesel fuel comes into contact with the coolant hoses. If necessary, the hoses must be cleaned immediately. Damaged hoses must be renewed.

1.3 Assembly overview - fuel filter

- Note safety precautions before beginning work
⇒ [page 172](#).
- Observe rules for cleanliness ⇒ [page 173](#).



- 1 - Fuel line
 - Check for secure seating
 - Connection overview ⇒ [page 174](#).
- 2 - 5 Nm
- 3 - Washer
- 4 - Fuel line
 - Check for secure seating
 - Connection overview ⇒ [page 174](#).
- 5 - Fuel line
 - Check for secure seating
 - Connection overview ⇒ [page 174](#).
- 6 - Fuel line
 - Check for secure seating
 - Connection overview ⇒ [page 174](#).
- 7 - Fuel filter upper part
 - Observe various types ⇒ [page 174](#)
 - Connection overview ⇒ [page 174](#).
 - Removing and installing ⇒ [page 175](#).
- 8 - Filter insert
 - Renewing ⇒ Maintenance; Booklet 26.1; Description of procedure; Fuel filter: renewing.
- 9 - Fuel filter lower part
- 10 - 10 Nm
- 11 - Seal
 - Renew ⇒ [page 175](#).

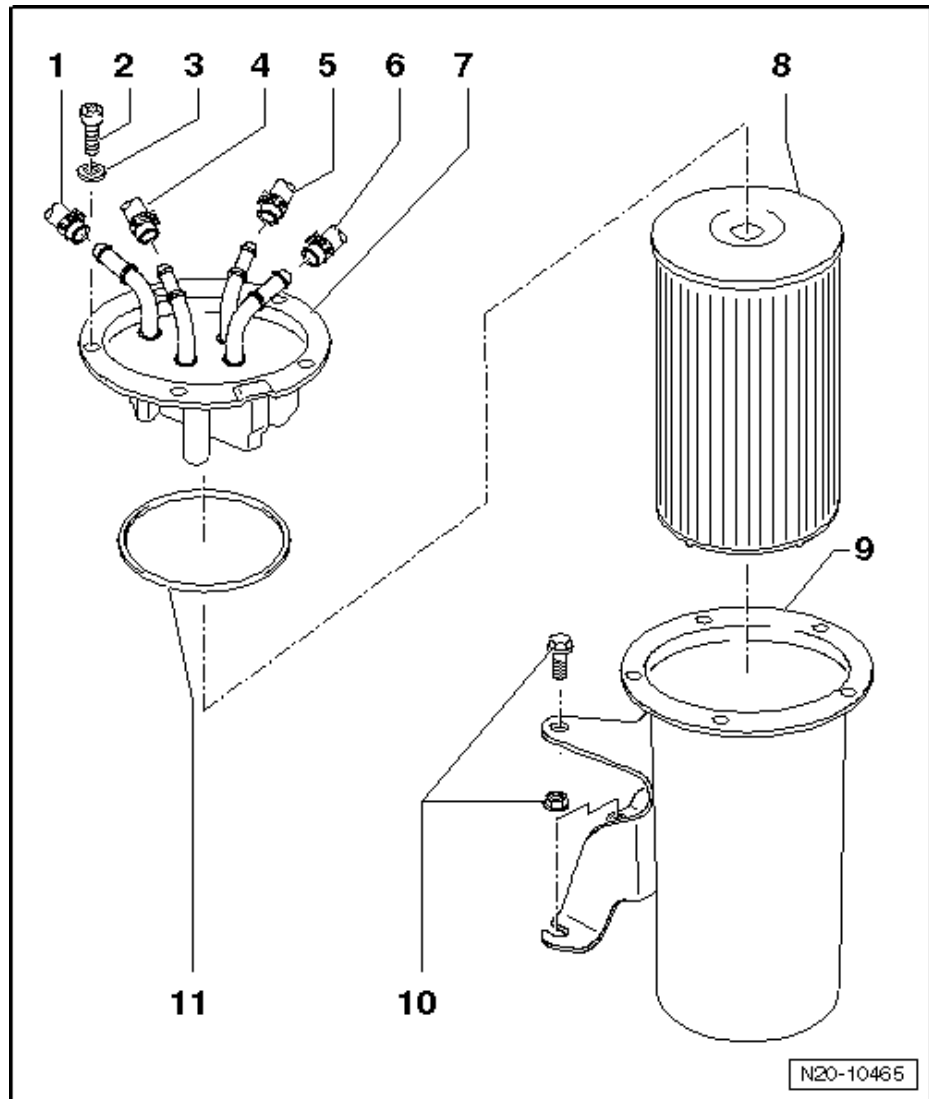

1.3.1 Fuel filter upper part

Type A ⇒ [Fig.](#)

Type B ⇒ [Fig. on page 175](#)



Fuel filter upper part, type A

- 1 - 8 Nm
- 2 - (Not necessarily installed) plug for water extraction (remove and extract about 100 cm³ liquid using hand-operated vacuum pump with accessories -V.A.G 1390- and water drainage container -V.A.G 1390/1-, renew seal).
- 3 - Fuel supply line from fuel tank, white or white marking. Check for secure seating.
- 4 - Fuel return line to fuel tank, blue or blue marking. Check for secure seating.
- 5 - Engine supply line, white or white marking. Check for secure seating.
- 6 - Engine return line, blue or blue marking. Check for secure seating.

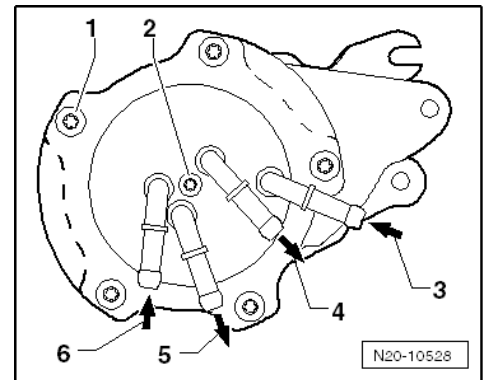

Fuel filter upper part, type B

- 1 - 5 Nm
- 2 - Fuel return line to fuel tank, blue or blue marking. Check for secure seating.
- 3 - Fuel supply line from fuel tank, white or white marking. Check for secure seating.
- 4 - Engine return line, blue or blue marking. Check for secure seating.
- 5 - Engine supply line, white or white marking. Check for secure seating.

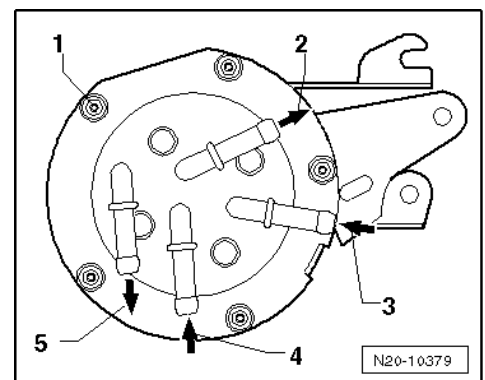

1.4 Removing and installing upper part of fuel filter

Special tools and workshop equipment required

- ◆ Diesel extractor -VAS 5226-

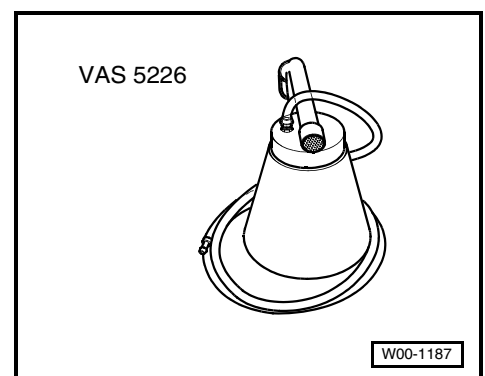

- ◆ Special wrench, long reach -VAS 6543-

Removing

⚠ Caution!

- ◆ **Do NOT pull fuel hoses off fuel filter cover and do NOT lever on connection. Prising/pulling can cause leaks and damage on the fuel filter upper part.**
- ◆ **Ensure that no diesel fuel contacts other components in the engine compartment. Clean immediately, if necessary.**

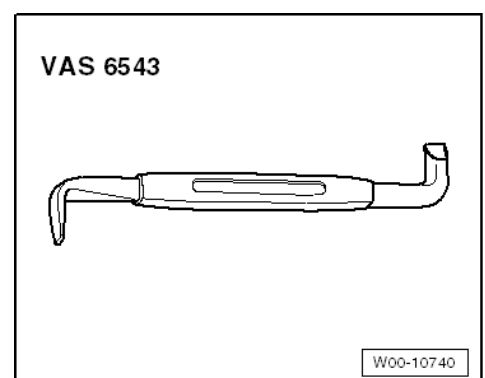



Procedure

- Remove all securing bolts ⇒ **item 2 on page 174** of fuel filter upper part and remove fuel filter upper part.

Note

If upper part of fuel filter is tight or seized, loosen upper part of fuel filter as follows:

Upper part of fuel filter can be raised using a special wrench, long reach -VAS 6543- in assembly groove -arrow A-.

- ◆ The size of the assembly groove can vary depending on version of upper part.
- Insert respective end of special wrench, long reach -VAS 6543- into assembly groove -arrow A- and turn special wrench, long reach -VAS 6543-.

This action raises the upper part of the fuel filter.

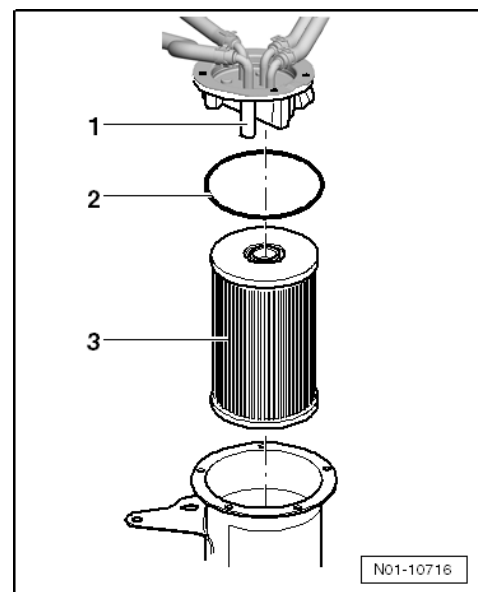
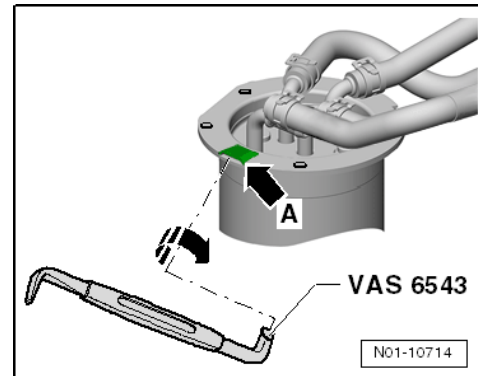
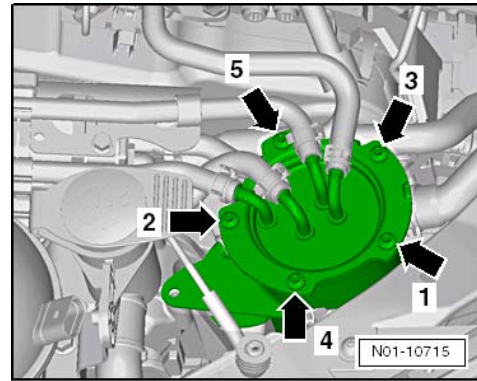



- Remove seal -2- from upper part of fuel filter -1- by prising seal out of respective groove -arrow-.

Installing

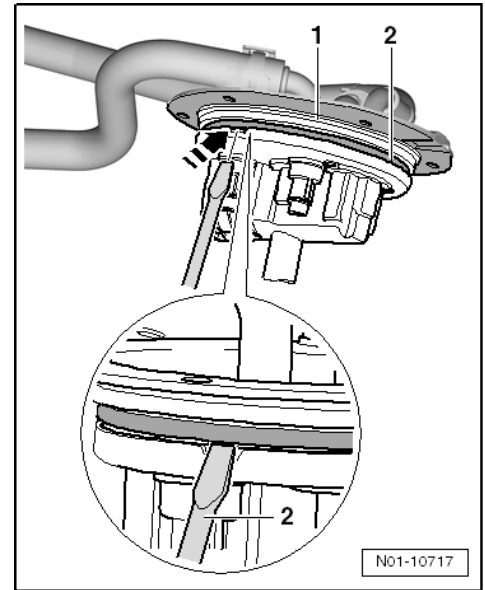

- Moisten new seal -1- lightly with diesel fuel and insert fuel filter upper part -arrows-.
- Fit fuel filter upper part with seal properly onto fuel filter lower part, press on firmly and evenly until the fuel filter upper part is seated correctly.

⚠ Caution!

Do NOT tighten bolts of upper part, before it is completely seated on the lower part.

- Screw all bolts into fuel filter lower part and tighten hand-tight.
- Then tighten bolts evenly, using diagonal sequence, to the specified torque ⇒ [item 2 on page 174](#).

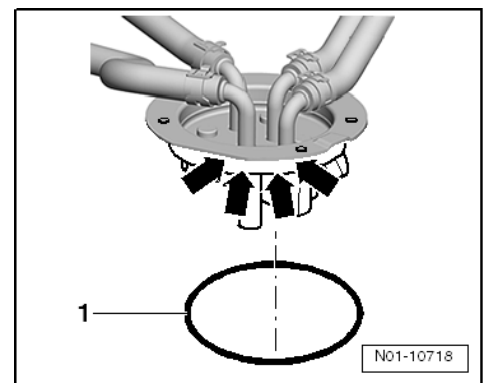

1.5 Removing and installing supplementary fuel pump -V393- (Inline EKP)

Special tools and workshop equipment required

- ◆ Hose clip pliers -VAS 6340-

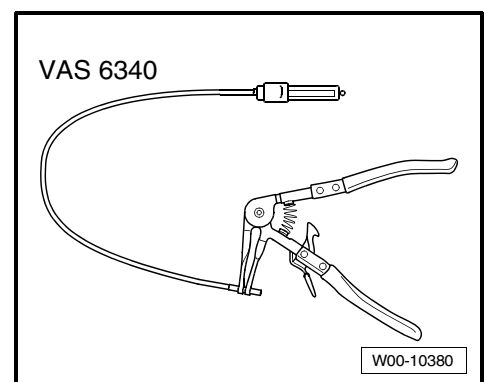



- ◆ Torque wrench -V.A.G 1331-

Removing

- Note safety precautions before beginning work
⇒ [page 172](#).
- Observe rules for cleanliness ⇒ [page 173](#).
- Free fuel hose ⇒ [item 6 on page 174](#), open clamp and pull fuel hose off fuel filter.
- Disconnect connector from fuel temperature sender -G81-
-arrow-, loosen clamp -1- and pull fuel supply line off high-
pressure pump.
- Unscrew securing bolts for supplementary fuel pump
-V393-.

Installing

Installation is carried out in the reverse sequence of removal.
In the process, note the following:

- ◆ Route fuel hoses without kinking.
- ◆ Ensure fuel hoses are tight.
- ◆ Do not interchange fuel supply and return lines (return line
is blue or with blue markings and supply line is white or
with white markings).
- ◆ Reclip fuel and coolant hoses into retainers.

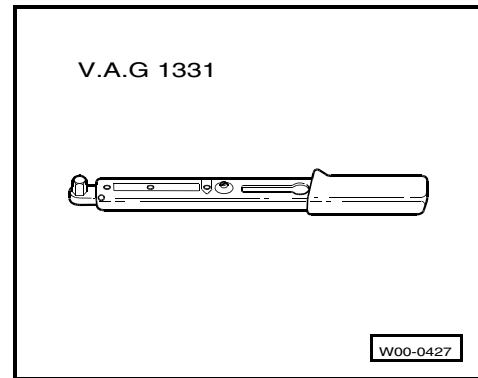

2 Checking components and functions

The component, functional tests and reference to current flow
diagrams ⇒ [page 305](#) are for standard components.

Refer to notes/instructions from respective clients of industri-
al engines for deviations with components and current flow
diagrams.

Checking supplementary fuel pump -V393- (inline electronic
fuel pump) ⇒ [page 179](#).

Checking accelerator position sender -G79- (when fitted)
⇒ [page 180](#).



2.1 Checking supplementary fuel pump -V393- (inline electronic fuel pump)

Special tools and workshop equipment required

- ◆ K-Jetronic pressure tester -V.A.G 1318-

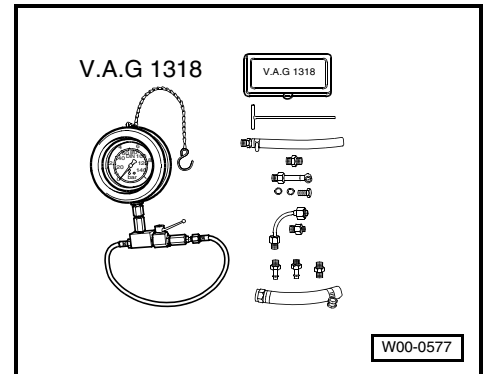

- ◆ Vehicle diagnosis, testing and information system -VAS 5051- with diagnosis cable -VAS 5051/6A-

Note

Other diagnosis testers can be used instead of the vehicle diagnosis, testing and information system.

Test prerequisites

- Battery voltage at least 11.5 V
- Fuel filter OK.
- Fuel tank: level min "reserve".
- Ignition switched off

Test procedure

- Note safety precautions before beginning work
⇒ [page 172](#).
- Observe rules for cleanliness ⇒ [page 173](#).

WARNING!

- ◆ **Wrap a clean cloth around the connection before opening the fuel system. Then release pressure by carefully pulling hose off connection.**

- Pull fuel supply line -arrow- off high-pressure pump.

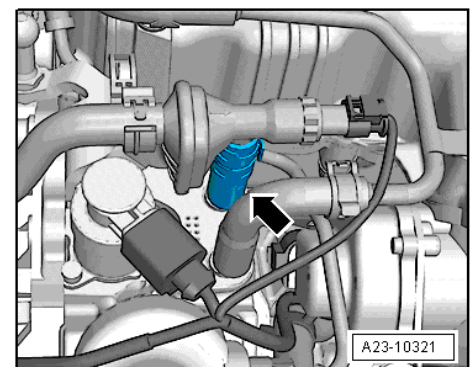
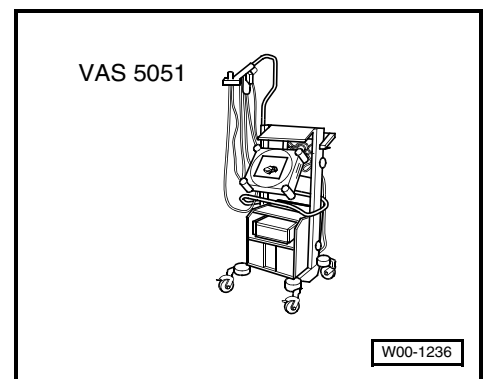



- Connect K-Jetronic pressure tester -V.A.G 1318- with suitable adapter -2- to fuel supply line -1-. Connect other adapter -3- from K-Jetronic pressure tester -V.A.G 1318- to open connection on high-pressure pump.

i Note

The K-Jetronic pressure tester -V.A.G 1318- must be inserted as an intermediate element into the fuel supply line.

- Switch on ignition.
- Carry out final control diagnosis and actuate fuel pump
⇒ page 47, Final control diagnosis.
- Run fuel pump until highest fuel pressure has built up.
- Specification: minimum 3.5 bar

If the specification is not attained:

- Check union between pressure gauge and fuel line for leaks.
- Test pressure gauge for leaks.
- Check fuel lines and their connections for leaks.

Check whether fuel filter is blocked.

If no fault is found:

Renew fuel pump.

i Note

Check fuel system for leaks.

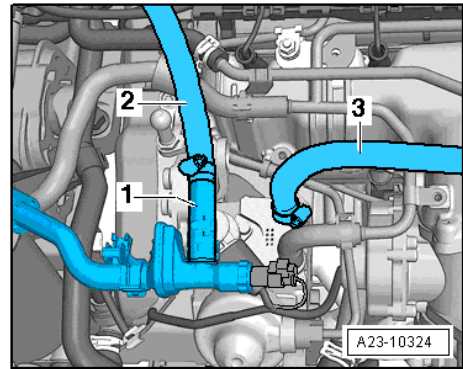

2.2 Checking accelerator position sender -G79- (when fitted)

Special tools and workshop equipment required

- ♦ Vehicle diagnosis, testing and information system -VAS 5051- with diagnosis cable -VAS 5051/6A-
- ♦ Hand multimeter -V.A.G 1526- or multimeter -V.A.G 1715-
- ♦ Adapter set -V.A.G 1594-
- ♦ Test box -V.A.G 1598/42- with adapter cable -V.A.G 1598/39-2-
- ♦ Current flow diagram

i Note

Other diagnosis testers can be used instead of the vehicle diagnosis, testing and information system.

Test prerequisites

- Fuses must be OK.
- The battery voltage must be at least 11.5 V.

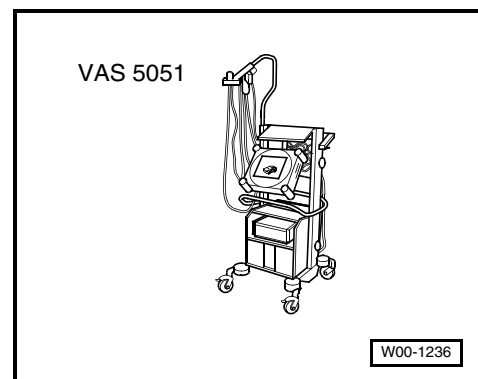



- All electrical consumers must be switched off.
- Earth connection OK.

Test procedure

Note

- ◆ *Due to the various installation applications, the following section can only show the basic notes concerning check of accelerator position sender.*
- ◆ *The accelerator position sender -G79- and the accelerator position sender 2 -G185- are installed together in a housing in the charge air pipe.*
- ◆ *Only gold-plated contacts may be used when repairing the accelerator position sender connector contacts.*
- Connect vehicle diagnosis, testing and information system -VAS 5051- and select diagnosis function “011-Read data block”. When doing this, the ignition must be switched on. (Connect vehicle diagnosis, testing and information system and select engine control unit ⇒ [page 3](#)).
- Select “Display group 2”.
- Check accelerator position display in display zone 2. The accelerator must not be depressed. Specification: 0.0 %.

Display group 2			
xxxx rpm	0.0 %	xxxx1x	xxx.x °C

Note

On the display of the vehicle diagnosis, testing and information system -VAS 5051- the display zones are displayed below one another and, next to one another on other diagnosis testers.

- In addition check the idling speed switch display in display zone 3. The 5th position from left must show 1. Display: xxxx1xxx
- Fully depress accelerator pedal slowly and observe display zones 2 and 3.

Display group 2			
xxxx rpm	100.0 %	xxxx0x	xxx.x °C

Display zone 2:

- The accelerator pedal position value must increase continuously. Specification at full throttle position: 100.0 %.

Display zone 3:

- The 5th position from the left must change to 0. Display: xxxx0xxx.
- Terminate diagnosis function.
- Switch off ignition.

If end specification is not reached:

- Renew accelerator position sender -G79-.
- Then read fault memory of engine control unit and clear fault memory if necessary ⇒ [page 7](#), Clearing fault memory.

Display does not change or is erratic:



- Switch off ignition.

Checking voltage supply

- Connect multimeter using auxiliary cables from -V.A.G 1594- to measure voltage at connector contacts 2 + 3.
- Switch on ignition. Specification: At least 4.8...5.2 V.
- Switch off ignition.
- Connect multimeter using auxiliary cables from -V.A.G 1594- to measure voltage at connector contacts 1 + 5.
- Switch on ignition. Specification: At least 4.8...5.2 V.
- Switch off ignition.
- Check accelerator position sender wiring as follows:
 - Connect test box -V.A.G 1598/42- to control unit wiring harness ⇒ [page 5](#) using adapter cable -V.A.G 1598/39-2-. The engine control unit is not connected by this action.
 - Pull 6-pin connector off accelerator position sender.
 - Check wiring between test box and connector for open circuit referring to current flow diagram.
 - ♦ Contact 1 + socket 13
 - ♦ Contact 2 + socket 15
 - ♦ Contact 3 + socket 74
 - ♦ Contact 4 + socket 53
 - ♦ Contact 5 + socket 8
 - ♦ Contact 6 + socket 54
 - Wire resistance: max. 2.0 Ω
- Also check wiring for short to one another, to battery earth/engine earth and to battery positive. Specification: ∞ Ω.

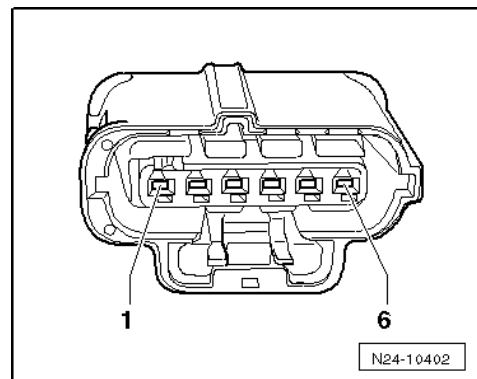
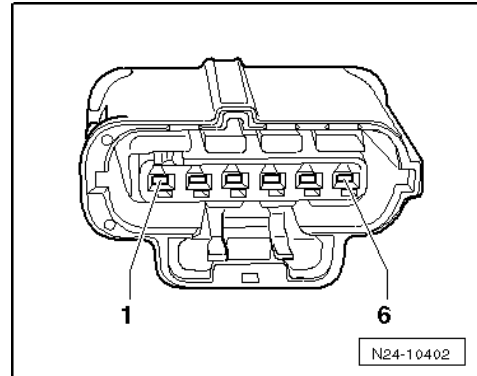

If no wiring fault is detected and voltage was present between contacts 2 + 3 and 1 + 5:

Renew accelerator position sender -G79-.

- Then read fault memory of engine control unit and clear fault memory if necessary ⇒ [page 7](#), Clearing fault memory.

If no wiring fault is detected and no voltage was present between contacts 2 + 3 and 1 + 5:

- Pull connectors off all components which are connected to this voltage supply line ⇒ [page 305](#), Current flow diagram.
- Check voltage supply and wiring for all these components.

If no wiring fault is detected and no voltage was present at these components:

- Renew engine control unit -J623- ⇒ [page 259](#).



21 – Turbocharging/supercharging

1 Charge air system with turbocharger

Observe safety precautions when working on charge air system with turbocharger ⇒ [page 183](#).

Observe rules for cleanliness ⇒ [page 183](#).

Assembly overview - turbocharger with attachments ⇒ [page 184](#).

Removing and installing turbocharger ⇒ [page 186](#).

Vacuum hose schematic diagram ⇒ [page 194](#).

1.1 Safety precautions when working on charge air system with turbocharger

WARNING!

Due to the cramped conditions, note the following when carrying out repairs:

- ◆ *Route all the various lines (e.g. for fuel, hydraulics, activated charcoal filter system, coolant, refrigerant, brake fluid and vacuum) and electrical wiring in their original positions.*
- ◆ *Ensure that there is sufficient clearance to all moving or hot components.*

Observe following if test and measuring instruments are required during a road test:

- ◆ Test and measuring instruments must be secured and operated by a second person.

1.2 Rules for cleanliness

When working on the turbocharger, pay careful attention to the following "rules" of cleanliness:

- ◆ Thoroughly clean all unions and adjacent areas before disconnecting.
- ◆ Place removed parts on a clean surface and cover. Use only lint-free cloths!
- ◆ Carefully cover opened components or seal if repairs cannot be carried out immediately.
- ◆ Only install clean components: Only unpack replacement parts immediately prior to installation. Do not use parts that have not been stored in their packing (e.g. in tool boxes etc.).
- ◆ Existing transport and protective packaging and sealing caps must only be removed immediately prior to installation.



- ◆ When performing repairs, clean connection and hose ends of oil.
- ◆ When system is open: Avoid working with compressed air if possible. Do not move vehicle unless absolutely necessary.

1.3 Assembly overview - turbocharger with attachments

Note

- ◆ All hose connections are secured.
 - ◆ Charge air system must be free of leaks.
 - ◆ When performing repairs, clean connection and hose ends of oil.
 - ◆ All hose connections of charge air system are secured by spring-type clips or by hose connections with connector couplings. Observe installation instructions ⇒ [page 188](#)
 - ◆ Spring-type clip pliers -VAS 5024- are recommended for installation of spring-type clips.
 - ◆ Renew self-locking nuts.
 - ◆ Before installing oil supply line, fill turbocharger at union with engine oil.
 - ◆ After installing turbocharger, allow engine to run at idling speed for about 1 minute to ensure that oil is supplied to turbocharger.
- Note safety precautions before beginning work ⇒ [page 183](#).
- Observe rules for cleanliness ⇒ [page 183](#).

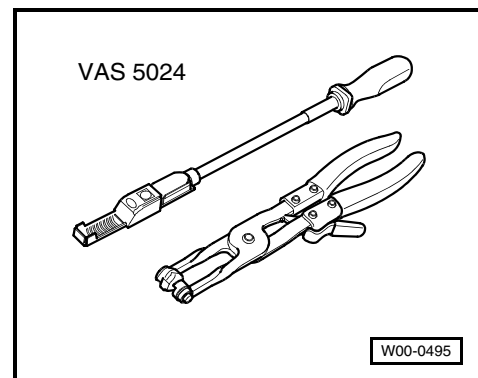



- 1 - 10 Nm**
- 2 - Oil supply line**
 - Before installing oil supply line, ensure that it is not blocked.
 - Before installing, fill turbocharger with engine oil through oil supply line connection.
- 3 - Turbocharger**
 - Can only be renewed together with exhaust manifold and vacuum unit.
 - Removing and installing ⇒ [page 186](#).
- 4 - Vacuum unit**
 - With position sender for charge pressure positioner -G581-
 - Checking position sender for charge pressure positioner -G581- ⇒ [page 202](#)
- 5 - Connector**
 - To position sender for charge pressure positioner -G581-
- 6 - Heat protection**
 - Renew if damaged.
- 7 - Gasket**
 - Renew.
- 8 - Connecting pipe**
 - To exhaust gas recirculation cooler.
- 9 - 20 Nm**
- 10 - Decoupling element**
 - Do not bend or stretch.
- 11 - Exhaust gas temperature sender 1 -G235-**
 - Exhaust gas temperature sender before turbocharger
 - 45 Nm
 - Lubricate thread of sender using high-temperature paste -G 052 112 A3-
 - Note installation position ⇒ [Fig. on page 186](#)
 - Checking ⇒ [page 204](#).
- 12 - 10 Nm**
- 13 - Bracket**
 - For oil supply line
- 14 - Heat shield**
- 15 - Support**
 - Between turbocharger and cylinder block

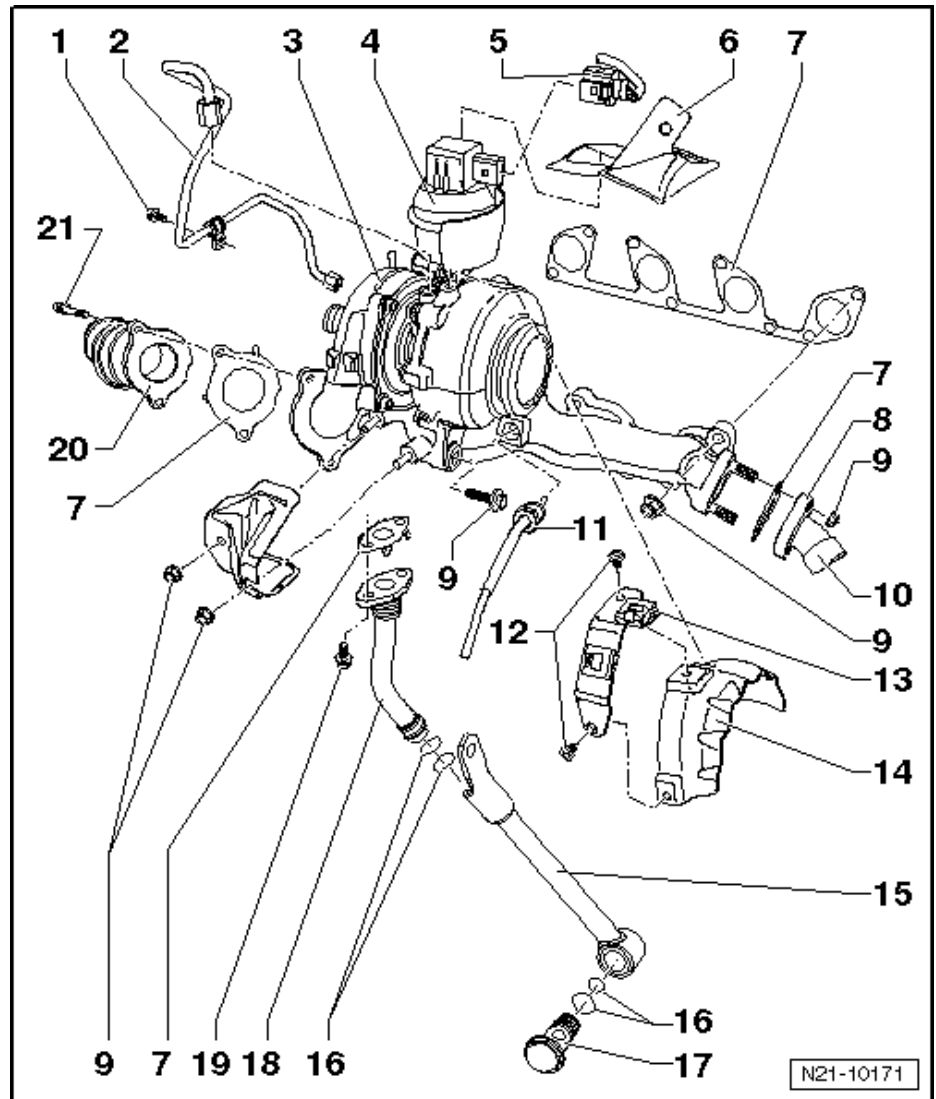



16- Seal

- Renew.

17- Banjo bolt, 60 Nm.

- Renew.

18- Oil return pipe

19- 15 Nm

20- Pulsation damper

21- 10 Nm

Installation position of exhaust gas temperature sender with angled cable guide



Note

When installing the exhaust gas temperature sender with angled cable guide, it is absolutely necessary to keep to dimension -a- of 3...5 mm when tightening the turbocharger support.

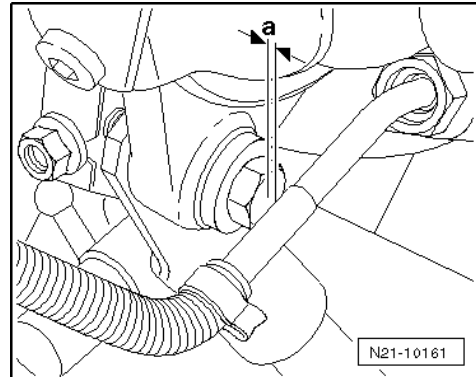

1.4 Removing and installing turbocharger

Special tools and workshop equipment required

- ◆ Torque wrench (5...50 Nm) -V.A.G 1331-



Caution!

When a mechanical fault is found on the turbocharger, e.g. a destroyed compressor impeller, it is not only sufficient to renew the turbocharger. To prevent this from causing further damage, perform the following repairs:

- ◆ Check air filter housing, air filter element and intake hoses for soiling.
- ◆ Check complete charged air routing and charge air cooler (when fitted) for foreign objects.

If foreign objects are found in the charge air system, the charged air routing must be cleaned and the charge air cooler must be renewed, if necessary.

Removing ⇒ page 186.

Installing ⇒ page 187.

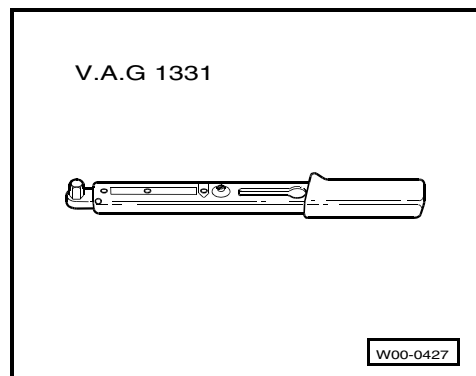

1.4.1 Removing

- Note safety precautions before beginning work
⇒ page 183.
- Observe rules for cleanliness ⇒ page 183.
- Pull connector off position sender for charge pressure positioner -G581- on turbocharger ⇒ item 5 on page 185.
- Pull vacuum hose off turbocharger.



- Disconnect electrical connector for exhaust gas temperature sender 1 -G235- (exhaust gas temperature sender before turbocharger) ⇒ **item 11 on page 185**.
- Unscrew oil supply pipe ⇒ **item 2 on page 185** at turbocharger.
- Unscrew securing bolt from charge air pipe, loosen clamp and pull connecting hose off turbocharger as far as it will go.
- Loosen clamp for turbocharger/particulate filter. Remove particulate filter ⇒ **page 266**.
- Remove connecting pipe to exhaust gas recirculation cooler.

! *Caution!*

The exhaust gas temperature sender 1 -G235- covers the upper threaded connection of the turbocharger support. The temperature sender must not become bent. It must therefore be removed.

- Remove exhaust gas temperature sender 1 -G235- (exhaust gas temperature sender before turbocharger).
- Remove banjo bolt ⇒ **item 17 on page 186** of turbocharger support.
- Unscrew upper bolt -arrow- from support on turbocharger.
- Turn lower part of support 90° and pull support downwards off upper part.
- Remove heat shield from exhaust manifold.
- Unscrew securing nuts for exhaust manifold.
- Remove turbocharger, if necessary, turn it so that intake side faces downwards and remove turbocharger downwards.

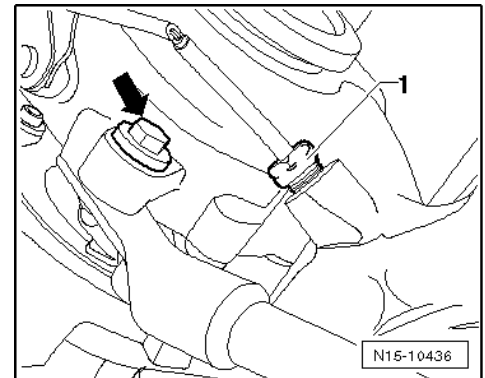

1.4.2 Installing

- Installation of turbocharger is basically the reverse of removal.

! *Caution!*

Before installing, check whether decoupling element of oil return line is bent and thus stretched. If this is the case, micro cracks can have formed and may cause leakage. If necessary, renew oil return line of turbocharger before installing.

- ◆ Fit turbocharger with pressure side facing upwards.
- ◆ Position connecting hose of charge air pipe before bolting on turbocharger.
- ◆ Note installation position of exhaust temperature sender 1 -G235- (exhaust gas temperature sender before turbocharger) ⇒ **Fig. on page 186**.



- ◆ Renew banjo bolt for turbocharger support and O-rings for oil return line.
- ◆ Do not overstretch decoupling element of oil return line when installing turbocharger support.

i Note

- ◆ *Before installing oil supply line, fill turbocharger at union with engine oil.*
- ◆ *After installing turbocharger, allow engine to run at idling speed for about 1 minute to ensure that oil is supplied to turbocharger.*

Specified torques ⇒ [page 184](#).

- Then read fault memory of engine control unit and clear fault memory if necessary ⇒ [page 7](#), Clearing fault memory.

2 Checking charge pressure system

i Note

- ◆ *All hose connections are secured.*
- ◆ *Charge air system must be free of leaks.*
- ◆ *When performing repairs, clean connection and hose ends of oil.*
- ◆ *All hose connections of charge air system are secured by spring-type clips or by hose connections with connector couplings. Observe installation instructions ⇒ [page 188](#)*
- ◆ *Spring-type clip pliers -VAS 5024- are recommended for installation of spring-type clips.*

Observe safety precautions when working on charge air system with turbocharger ⇒ [page 183](#).

Observe rules for cleanliness ⇒ [page 183](#).

Installing hose connections with connector couplings ⇒ [page 188](#)

Checking charge air system for leaks ⇒ [page 190](#).

Checking charge pressure control ⇒ [page 192](#).

Vacuum hose schematic diagram ⇒ [page 194](#).

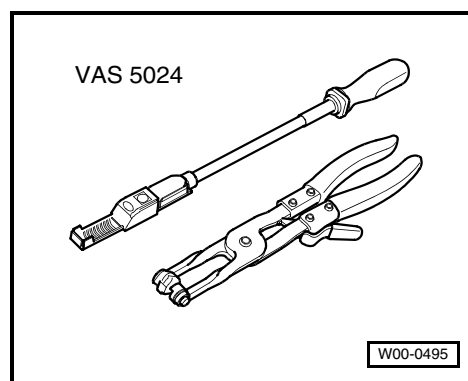

2.1 Installing hose connections with connector couplings

- Note safety precautions before beginning work ⇒ [page 183](#).
- Observe rules for cleanliness ⇒ [page 183](#).

Dismantling ⇒ [page 189](#)

Assembling ⇒ [page 189](#)

2.1.1 Dismantling

Version with locating lug

- Press connector coupling on connecting hose together -arrow 1-.

i Note

The connector coupling can only be released completely when the retaining clip -1- is pressed together.

- Bring retaining clip to release position -arrow 2-.
- Separate connector coupling without using tools.

Version with no locating lug

- Release push-on connector by pulling securing clip -1-. Pull hose/pipe-2- off without the use of tools.

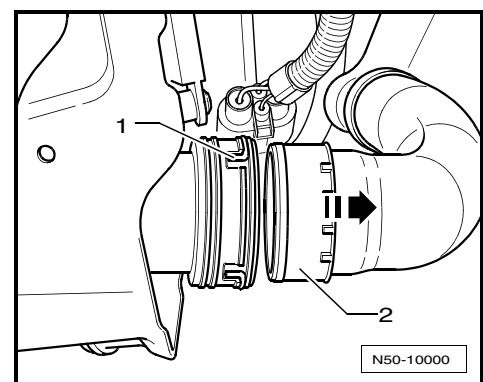
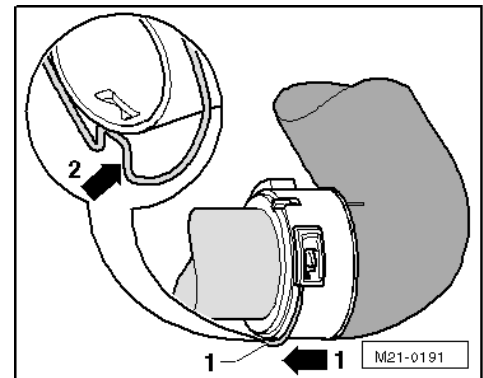

2.1.2 Mounting

Version with locating lug

! Caution!

The seal of the connector coupling can be damaged if the securing clip is in locking position when installing. Leaks could occur. Observe installation instructions.

- Clean sealing surfaces in connector coupling.
- If seal is renewed, place seal in groove of connecting hose. Ensure the seal is correctly seated in the groove.
- Lightly lubricate sealing surface and seal.
- Bring retaining clip -1- to release position.
- Push connecting hose into coupling to stop. When doing this, note locating lug -2-.
- Bring retaining clip to locking position -4-. The retaining clip locks into locking groove -3-.
- Then push against connecting hose again.
- Check if connector coupling seats correctly and is properly engaged by pulling on connecting hose.

Version with no locating lug

- If renewed, place seal in groove of charge air hose. Ensure the seal is correctly seated in the groove.
- Oil sealing surface and seal.
- Bring securing clip to release position -1-.
- Push charge air hose into coupling to stop.

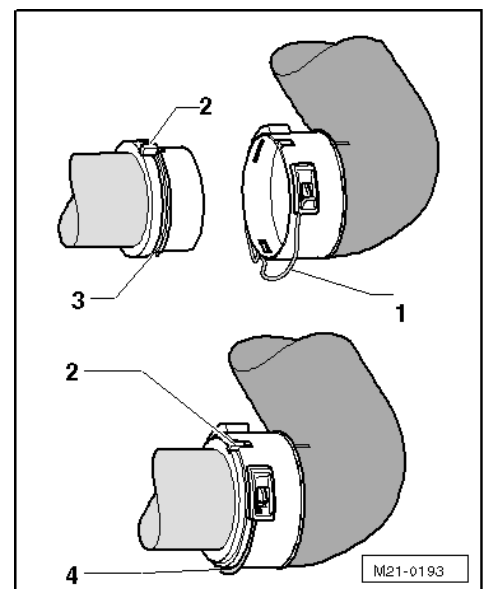



- Bring securing clip to locking position -2- and then push charge air hose again.
- Check if connector coupling seats correctly and is properly engaged by pulling hose.

2.1.3 Installing hose connections with spring-type clamps

Note

There is a danger of a "hose detaching" whilst driving after removing and reinstalling charge pressure lines with spring-type clamps. For this reason, spring-type clips are used which can be opened if a defect item requires the charge pressure line has to be disconnected. In cases of repair, destroy the spring-type clip using a suitable tool and replace it with a replacement part from ⇒ ETKA (electronic parts catalogue).

2.2 Checking charge air system for leaks

Special tools and workshop equipment required

- ◆ Charge air system tester -V.A.G 1687-
- ◆ Adapter -V.A.G 1687/10-

Test procedure

- Note safety precautions before beginning work ⇒ [page 183](#).
- Observe rules for cleanliness ⇒ [page 183](#).

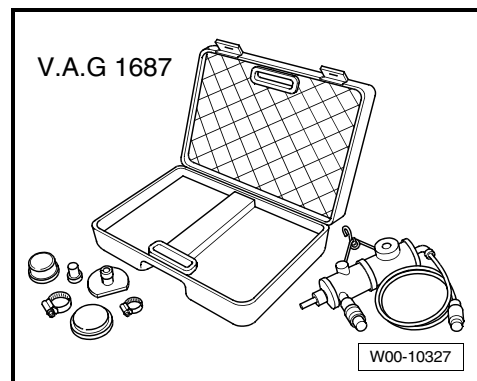
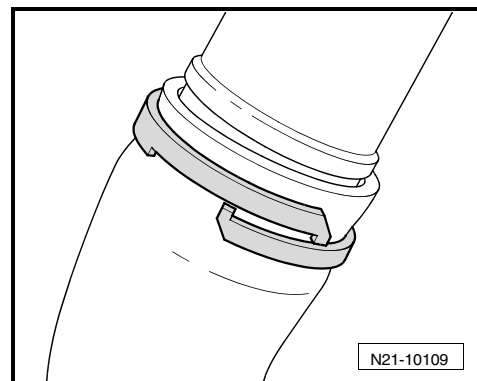
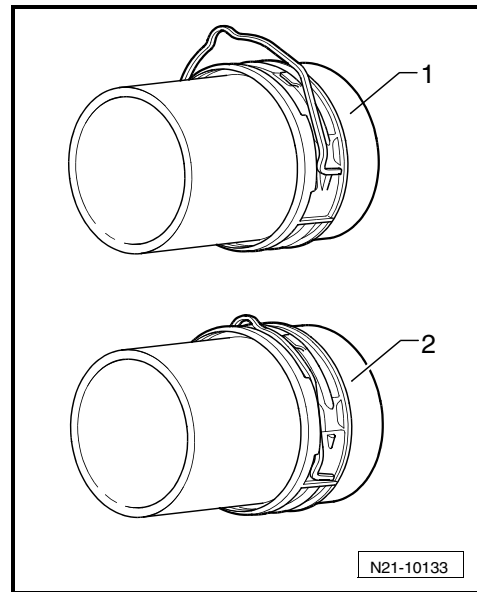

- Remove intake hose -1- from air filter.
- Connect adapter -1687/10- in intake hose -1- and secure with clip.

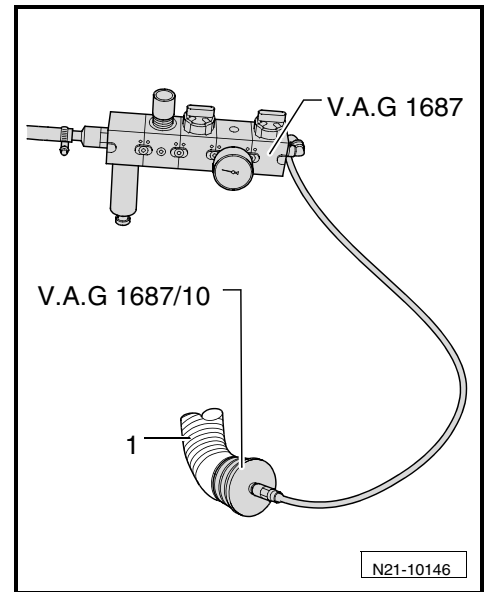

Prepare charge air system tester -V.A.G 1687- as follows:

- Unscrew pressure regulating valve -2- and close valves -3- and -4-.



Note

To turn the pressure regulating valve -2- the knob must be pulled upwards.

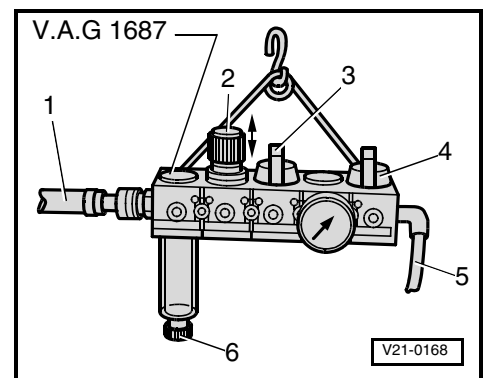

- Connect charge air system tester -V.A.G 1687- to adapter -1687/10- as shown.

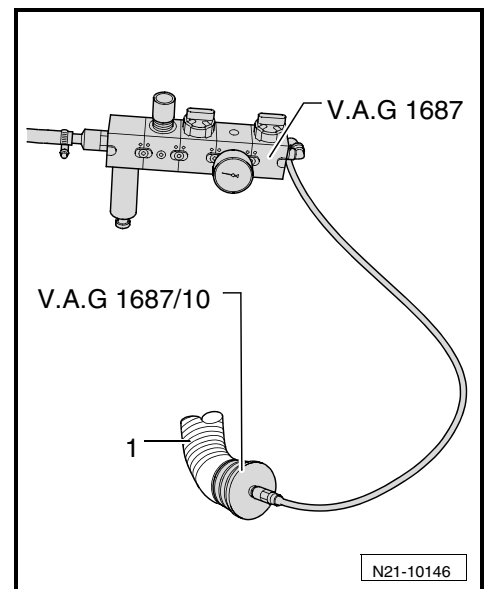



- Connect compressed air hose -1- (compressed air source) to charge air system tester -V.A.G 1687-.

i Note

If there is water in the sight glass, drain at water drain screw -6-.

- Open valve -3-.
- Adjust pressure to 0.5 bar with pressure regulating valve -2-.

! Caution!

The test pressure must not exceed 0.5 bar! If the pressure is too high this can cause damage to the engine.

- Open valve -4- and wait until the test circuit is filled. If necessary readjust pressure to 0.5 bar.
- Check the charge air system for leaks by hearing, touching, with commercially available leak detector spray or using ultrasonic tester -V.A.G 1842-.

i Note

- ♦ How to use the ultrasonic tester -V.A.G 1842-
⇒ operating instructions
- ♦ If leaks occur, when doing any repair work observe notes for charge air system ⇒ [page 188](#).
- ♦ Before removing the charge air system tester -V.A.G 1687- depressurise the test circuit by pulling coupling off adapter -1687/10-.

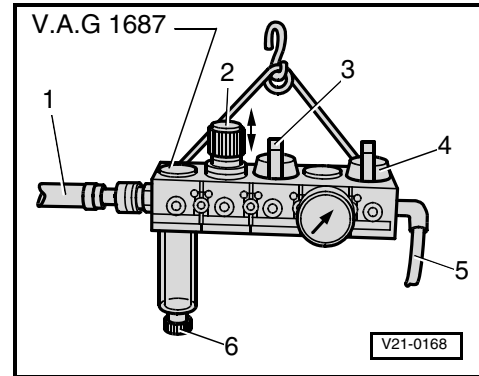

2.3 Checking charge pressure control

Special tools and workshop equipment required

- ♦ Vehicle diagnosis, testing and information system -VAS 5051- with diagnosis cable -VAS 5051/6A-

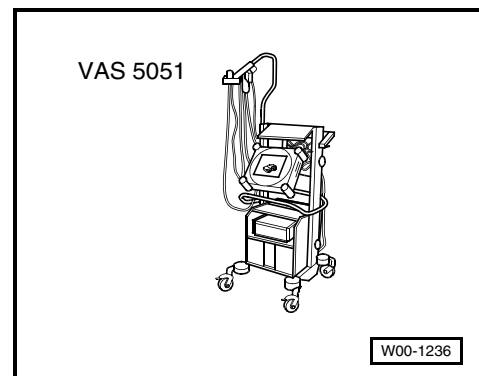



- ◆ Hand vacuum pump with accessories -V.A.G 1390-

i Note

Other diagnosis testers can be used instead of the vehicle diagnosis, testing and information system.

Test prerequisites

- Fuses must be OK.
- The battery voltage must be at least 11.5 V.
- All electrical consumers must be switched off.
- Earth connection OK.
- No leaks on intake and exhaust systems.
- No faults in engine, fuel injection system or compression pressures.
- No faults must be stored in fault memory ⇒ [page 7](#), Reading fault memory.
- Coolant temperature must be at least 80 °C, ⇒ display group 1, display zone 4.

Test procedure

- Carry out final control diagnosis and activate charge pressure regulation solenoid valve -N75- ⇒ [page 47](#), Final control diagnosis.

The displays in display zones 2, 3 and 4 must fluctuate within following control range:

Display zone 2: off:

- Specification in display zone 3: 900...1150 mbar
- Specification in display zone 4: 90...5 %

Display zone 2: on:

- Specification in display zone 3: 100 mbar greater than for display off
- Specification in display zone 4: at least 95 %

i Note

- ◆ *The activation of the valve can be checked by touch.*
- ◆ *During the activation, the turbocharger charge pressure control actuator rods must move back and forth.*
- Check that charge pressure control solenoid valve -N75- clicks.
- During final control diagnosis, observe turbocharger linkage.
- Proceed with final control diagnosis until completed.
- Terminate diagnosis function.
- Switch off ignition.

If linkage does not move but solenoid valve operates:

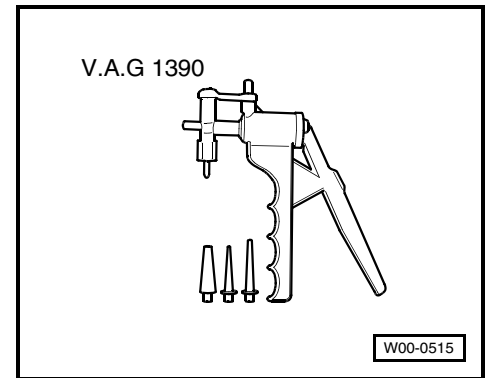



- Pull vacuum hose off charge air control vacuum unit.
- Connect hand vacuum pump -V.A.G 1390- to charge pressure control vacuum unit and check linkage for ease of movement.

If linkage does not move freely:

- Turbocharger defective. Renew turbocharger ⇒ [page 186](#), Removing and installing turbocharger.

If linkage does not move because solenoid valve is not working:

- Check charge pressure control solenoid valve -N75- ⇒ [page 197](#).

If specification in display zone 4: Always 0 %:

- Check vacuum hoses for leaks. Vacuum hose schematic diagram ⇒ [page 194](#).
- Check position sender for charge pressure positioner -G581- ⇒ [page 202](#).

If the difference of the charge air pressure in display zone 3 between "OFF" and "ON" is not at least 100 mbar:

- Check charge air pressure sender -G31- ⇒ [page 199](#).
- Check charge air pressure ducting for leaks ⇒ [page 190](#).

If the charge air pressure sender -G31- and the ducting is OK.:

- Turbocharger defective. Renew turbocharger ⇒ [page 186](#), Removing and installing turbocharger.

2.4 Schematic diagram of vacuum hoses

Testing vacuum system ⇒ [page 195](#).



Caution!

Do not kink, twist or crush the vacuum lines when routing. This may cause breakdowns.



- 1 - Vacuum unit
 - On turbocharger.
 - With position sender for charge pressure positioner -G581-
- 2 - Charge pressure control solenoid valve -N75-
- 3 - From brake servo
- 4 - To vacuum pump
- 5 - Connection piece
 - On exhauster pump
- 6 - Non-return valve
 - Note installation position.
- 7 - Air filter
- 8 - Intake silencer
- 9 - Cylinder head cover
- 10 - Junction

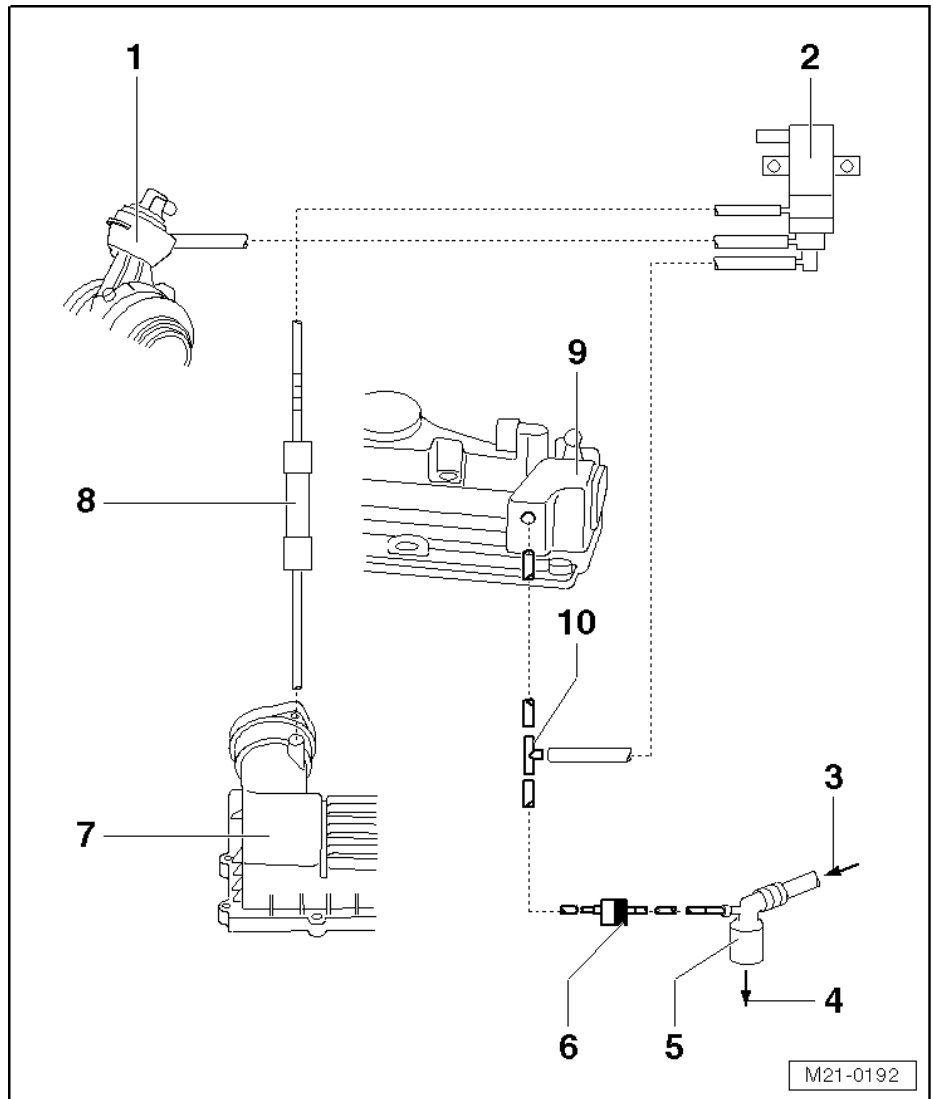

2.5 Testing vacuum system

Checking supply line and non-return valve ⇒ [page 196](#).

Checking control line to turbocharger ⇒ [page 196](#).

Special tools and workshop equipment required

- ◆ Hand vacuum pump -VAS 6213-

! Caution!

- ◆ *Do not kink, twist or crush the vacuum lines when routing. This may cause breakdowns.*
- ◆ *Observe safety precautions when working on charge air system and turbocharger ⇒ [page 183](#).*
- ◆ *Observe rules for cleanliness ⇒ [page 183](#).*

Follow these instructions before starting work and while working on system.

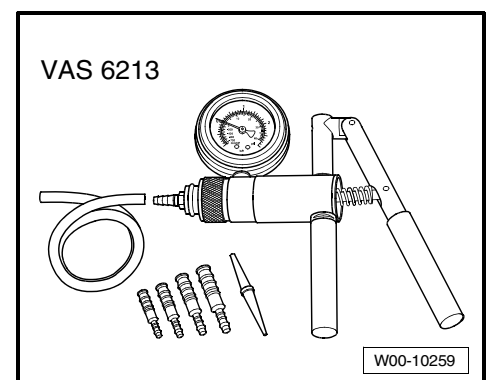



2.5.1 Checking supply line and non-return valve

Pull vacuum hose off lower union of charge pressure control solenoid valve -N75- -arrow in II-.

- Seal open end of hose with a suitable sealing plug.



Note

Do not use screws or threaded bolts.

- Pull vacuum hose -arrow- off connection piece of vacuum pump.
- Connect hand vacuum pump -VAS 6213- to disconnected hose and generate a vacuum of 0.6 bar.
- Observe gauge of hand vacuum pump -VAS 6213- for approx. 30 seconds.

- Vacuum must not drop.

If vacuum drops:

- Locate damage or leak in hose and replace corresponding length of hose.

If pressure does not drop:

- First pull hose off hand-operated vacuum pump -VAS 6213-.
- Remove sealing plugs from hose ends.
- If the non-return valve ⇒ [item 6 on page 195](#) functions properly, a clear hiss is audible when vacuum in vacuum reservoir is released.

If no hiss is audible:

- Renew non-return valve ⇒ [item 6 on page 195](#).

If a hiss is audible:

- Reconnect all disconnected vacuum hoses.
- Check control line to turbocharger ⇒ [page 196](#).

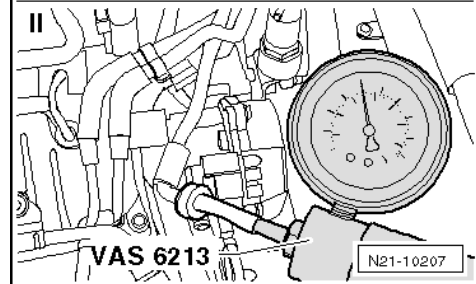
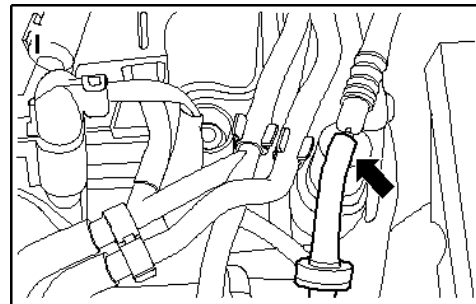
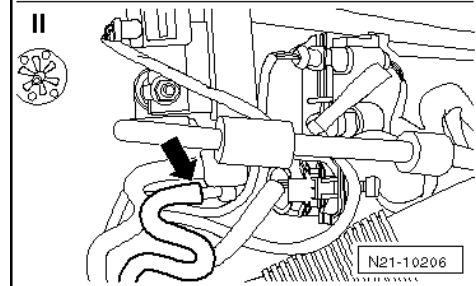
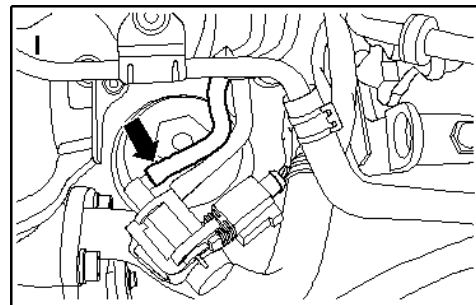

2.5.2 Checking control line to turbocharger

- Pull vacuum hose off middle connector from charge pressure control solenoid valve -N75- ⇒ [item 2 on page 195](#) and off turbocharger vacuum unit ⇒ [item 1 on page 195](#).



- Seal one opening of hose with a suitable sealing plug.

i **Note**

Do not use screws or threaded bolts.

- Connect hand vacuum pump -VAS 6213- to other end of hose and generate a vacuum of 0.6 bar.
- Observe gauge of hand vacuum pump -VAS 6213- for approx. 30 seconds.
- Vacuum must not drop.

If vacuum drops:

- Renew vacuum hose.
- Reconnect all disconnected vacuum hoses.

If pressure does not drop:

- Reconnect all disconnected vacuum hoses.

3 Checking components and functions

The component, functional tests and reference to current flow diagrams ⇒ [page 305](#) are for standard components.

Refer to notes/instructions from respective clients of industrial engines for deviations with components and current flow diagrams.

Check charge pressure control solenoid valve -N75- ⇒ [page 197](#).

Check charge air pressure sender -G31- ⇒ [page 199](#).

Check position sender for charge pressure positioner -G581- ⇒ [page 202](#)

Check exhaust gas temperature sender 1 -G235- (exhaust gas temperature sender before turbocharger) ⇒ [page 204](#).

3.1 Check charge pressure control solenoid valve -N75-

Special tools and workshop equipment required

- ◆ Vehicle diagnosis, testing and information system -VAS 5051- with diagnosis cable -VAS 5051/6A-
- ◆ Hand multimeter -V.A.G 1526- or multimeter -V.A.G 1715-
- ◆ Adapter set -V.A.G 1594-
- ◆ Test box -V.A.G 1598/42- with adapter cable -V.A.G 1598/39-1-
- ◆ Current flow diagram

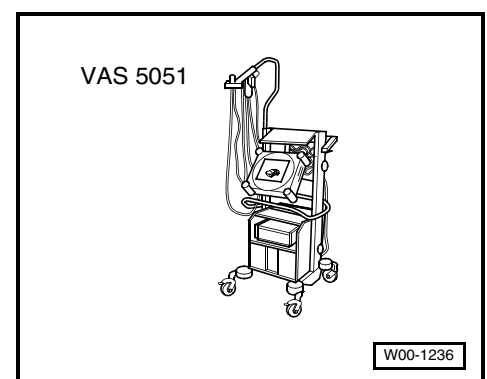



i Note

Other diagnosis testers can be used instead of the vehicle diagnosis, testing and information system.

Test prerequisites

- Fuses must be OK.
- The battery voltage must be at least 11.5 V.
- All electrical consumers must be switched off.
- Earth connection OK.
- Coolant temperature must be at least 80 °C, ⇒ display group 1, display zone 4.

Test procedure

- Carry out final control diagnosis and activate charge pressure regulation solenoid valve -N75- ⇒ [page 47](#), Final control diagnosis.

The display in display zone 2 must fluctuate between “OFF” and “ON”.

i Note

- ♦ *The activation of the valve can be checked by touch.*
- ♦ *During the activation, the turbocharger charge pressure control actuator rods must move back and forth.*
- Proceed with final control diagnosis until completed.
- Terminate diagnosis function.
- Switch off ignition.

If the valve is not activated:

- Pull 2-pin connector off charge pressure control solenoid valve -N75- ⇒ [item 2 on page 195](#).

Checking resistance

- Connect multimeter to measure resistance at contacts of valve using auxiliary cables from -V.A.G 1594-. Specification: 14.0...20.0 Ω.

i Note

At room temperature the resistance is in the lower tolerance range, and at operating temperature in the upper tolerance range.

If the specification is not attained:

- Renew charge pressure regulation solenoid valve -N75-.
- Then read fault memory of engine control unit and clear fault memory if necessary ⇒ [page 7](#), Clearing fault memory.

If specification is attained:

Checking voltage supply

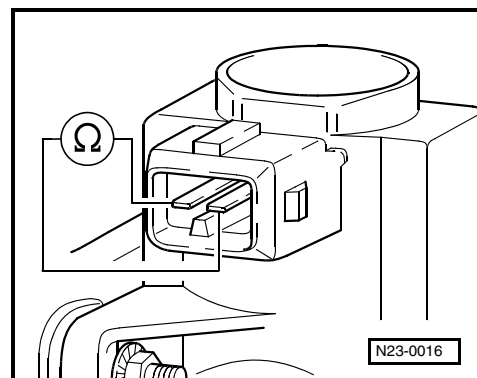



- Connect multimeter to measure voltage at connector contact 1 and engine earth using auxiliary cables from -V.A.G 1594-.
- Switch on ignition. Specification: At least 11.5 V.
- Switch off ignition.

If the specification is not attained:

- Check terminal 30 voltage supply relay -J317-
⇒ [page 305](#), Current flow diagram.
- Check cable connections for open circuit, short circuit and transfer resistance at contacts according to current flow diagram.

If specification is attained:

- Check charge pressure control solenoid valve wiring as follows:
- Connect test box -V.A.G 1598/42- to control unit wiring harness ⇒ [page 5](#) using adapter cable -V.A.G 1598/39-1-. The engine control unit is not connected by this action.
- Check wiring between test box and connector for open circuit referring to current flow diagram.
- ◆ Contact 2 + socket 20
- Wire resistance: max. 2.0 Ω
- Additionally check wires for short to one another. Specification: ∞ Ω.

If no wiring fault is detected and voltage supply is OK:

- Renew engine control unit -J623- ⇒ [page 259](#).

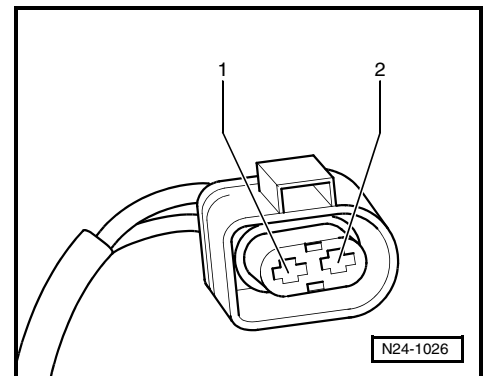
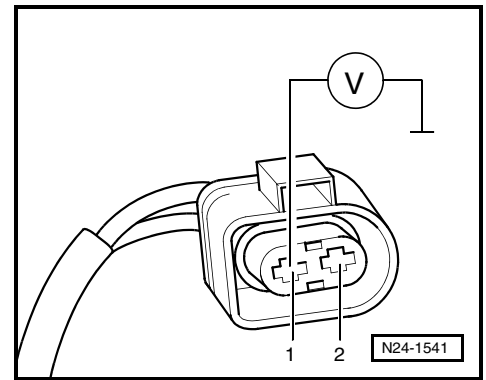

3.2 Checking charge air pressure sender -G31-

Special tools and workshop equipment required

- ◆ Vehicle diagnosis, testing and information system -VAS 5051- with diagnosis cable -VAS 5051/6A-

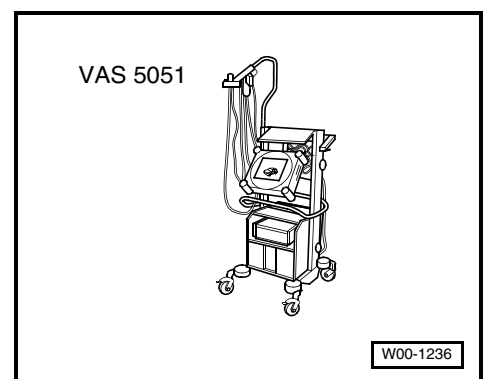



- ◆ Turbocharger tester -V.A.G 1397 A-
- ◆ Hand multimeter -V.A.G 1526- or multimeter -V.A.G 1715-
- ◆ Adapter set -V.A.G 1594-
- ◆ Test box -V.A.G 1598/42- with adapter cable -V.A.G 1598/39-2-
- ◆ Current flow diagram

i Note

Other diagnosis testers can be used instead of the vehicle diagnosis, testing and information system.

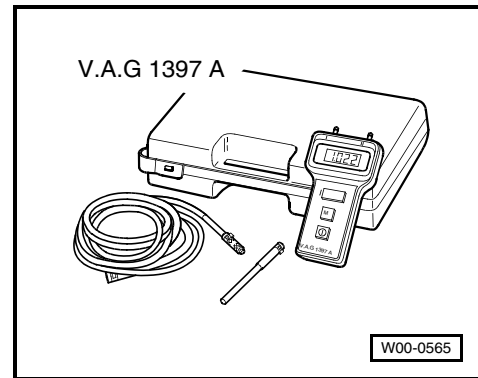

Test prerequisites

- Fuses must be OK.
- The battery voltage must be at least 11.5 V.
- All electrical consumers must be switched off.
- Earth connection OK.

Test procedure

i Note

- ◆ *The charge air pressure sender -G31- and the intake air temperature sender -G42- are installed together in a housing in the charge air pipe.*
- ◆ *Only gold-plated contacts may be used when repairing the connector contacts.*
- Connect vehicle diagnosis, testing and information system -VAS 5051- and select diagnosis function "011-Read data block". The ignition must be switched on for this purpose. (Connect fault reader and select engine control unit -J623- ⇒ [page 3](#)).
- Select "Display group 11".

Indicated on display:

i Note

On the display of the vehicle diagnosis, testing and information system -VAS 5051- the display zones are displayed below one another and, next to one another on other diagnosis testers.

- Check charge air pressure (actual) specification in display zone 3.
- Compare actual charge air pressure displayed with display on turbocharger tester -V.A.G 1397 A-. Specification: Pressures must correspond (tolerance ± 50 mbar).

i Note

The turbocharger tester -V.A.G 1397 A- is required to provide an independent figure for comparison. The turbocharger tester must be set to measuring range I (absolute pressure). A barometer can be used instead.

Display group 11
xxxx rpm xxxx mbar 978 mbar xxx %



- Terminate diagnosis function.
- Switch off ignition.

If the specification is not attained:

Checking voltage supply

- Pull 4-pin connector -5- off charge air pressure sender -G31-.

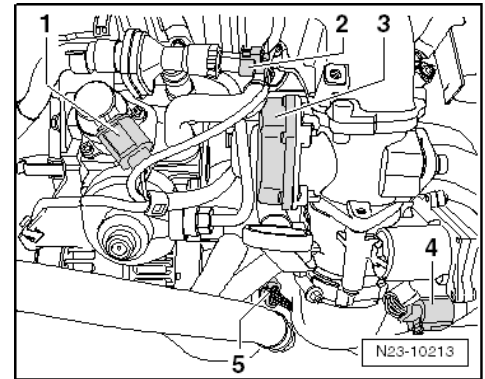

- Connect multimeter using auxiliary cables from -V.A.G 1594- to measure voltage at connector contacts 1 + 3.
- Switch on ignition. Specification: At least 4.8...5.2 V.
- Switch off ignition.
- Check charge air pressure sender wiring as follows:
- Connect test box -V.A.G 1598/42- to control unit wiring harness ⇒ [page 5](#) using adapter cable -V.A.G 1598/39-2-. The engine control unit is not connected by this action.

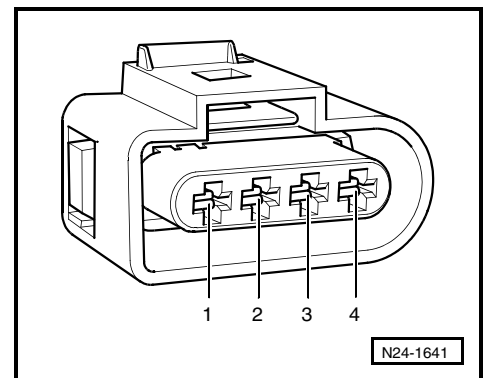

Note

The charge air pressure sender -G31- and the intake air temperature sender -G42- are installed together in a housing in the charge air pipe.

- Check wiring between test box and connector for open circuit referring to current flow diagram.
- ◆ Contact 3 + socket 17
- ◆ Contact 4 + socket 83
- Wire resistance: max. 2.0 Ω
- Also check wiring for short to one another, to battery earth/engine earth and to battery positive. Specification: ∞ Ω.

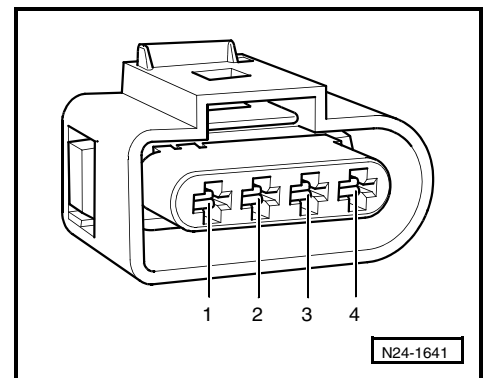

If no wiring fault is detected and voltage was present between contacts 1 + 3:

- Renew charge air pressure sender -G31- with intake air temperature sender -G42-.
- Then read fault memory of engine control unit and clear fault memory if necessary ⇒ [page 7](#), Clearing fault memory.

If no wiring fault is detected and no voltage was present between contacts 1 + 3:



- Pull connectors off all components which are connected to this voltage supply line ⇒ [page 305](#), Current flow diagram.
- Check voltage supply and wiring for all these components.

If no wiring fault is detected and no voltage was present at these components:

- Renew engine control unit -J623- ⇒ [page 259](#).

3.3 Checking position sender for charge pressure positioner -G581-

Special tools and workshop equipment required

- ◆ Vehicle diagnosis, testing and information system -VAS 5051- with diagnosis cable -VAS 5051/6A-
- ◆ Hand multimeter -V.A.G 1526- or multimeter -V.A.G 1715-
- ◆ Adapter set -V.A.G 1594-
- ◆ Test box -V.A.G 1598/42- with adapter cable -V.A.G 1598/39-1-
- ◆ Current flow diagram



Note

Other diagnosis testers can be used instead of the vehicle diagnosis, testing and information system.

Test prerequisites

- Fuses must be OK.
- The battery voltage must be at least 11.5 V.
- All electrical consumers must be switched off.
- Earth connection OK.
- Vacuum hoses OK.
- Coolant temperature must be at least 80 °C, ⇒ display group 1, display zone 4.

Test procedure

- Carry out final control diagnosis and activate charge pressure regulation solenoid valve -N75- ⇒ [page 47](#), Final control diagnosis.

The displays in display zones 2, 3 and 4 must fluctuate within following control range:



Note

On the display of the vehicle diagnosis, testing and information system -VAS 5051- the display zones are displayed below one another and, next to one another on other diagnosis testers.

Display zone 2: off:

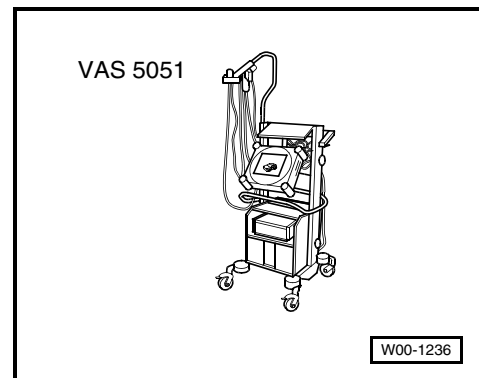



- Specification in display zone 3: 900...1150 mbar
- Specification in display zone 4: 90...5 %

Display zone 2: on:

- Specification in display zone 3: 100 mbar greater than for display off
- Specification in display zone 4: at least 95 %



Note

Specification in display zone 3: If the difference of the charge air pressure between "off" and "on" must be at least 100 mbar.

- Terminate diagnosis function.
- Switch off ignition.

If the specifications are not achieved or display zone 4 always displays 0:

Checking voltage supply

- Pull 3-pin connector off position sender for charge pressure positioner -G581- ⇒ [item 4 on page 185](#).
- Connect multimeter using auxiliary cables from -V.A.G 1594- to measure voltage at connector contacts 1 + 3.
- Switch on ignition. Specification: At least 4.8...5.2 V.
- Switch off ignition.
- Check position sender for charge pressure positioner -G581- wiring as follows:
- Connect test box -V.A.G 1598/42- to control unit wiring harness ⇒ [page 5](#) using adapter cable -V.A.G 1598/39-1-. The engine control unit is not connected by this action.
- Check wiring between test box and connector for open circuit referring to current flow diagram.
- ◆ Contact 1 + socket 53
- ◆ Contact 2 + socket 58
- ◆ Contact 3 + socket 25
- Wire resistance: max. 2.0 Ω
- Also check wiring for short to one another, to battery earth/engine earth and to battery positive. Specification: ∞ Ω.

If no wiring fault is detected and voltage was present between contacts 1 + 3:

- Renew position sender for charge pressure positioner -G581-.
- Perform adaption of position sender for charge pressure positioner -G581- ⇒ [page 262](#).

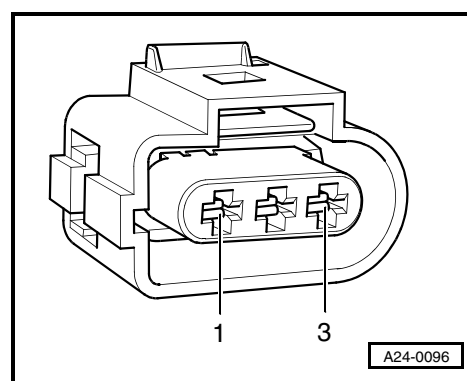
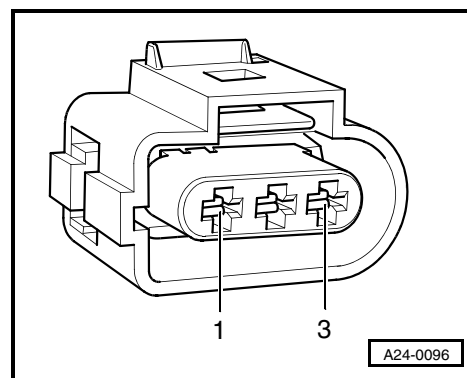



- Then read fault memory of engine control unit and clear fault memory if necessary ⇒ [page 7](#), Clearing fault memory.

If no wiring fault is detected and no voltage was present between contacts 1 + 3:

- Pull connectors off all components which are connected to this voltage supply line ⇒ [page 305](#), Current flow diagram.
- Check voltage supply and wiring for all these components.

If no wiring fault is detected and no voltage was present at these components:

- Renew engine control unit -J623- ⇒ [page 259](#).

3.4 Checking exhaust gas temperature sender 1 -G235- (exhaust gas temperature sender before turbocharger)

Special tools and workshop equipment required

- ♦ Vehicle diagnosis, testing and information system -VAS 5051- with diagnosis cable -VAS 5051/6A-
- ♦ Hand multimeter -V.A.G 1526- or multimeter -V.A.G 1715-
- ♦ Adapter set -V.A.G 1594-
- ♦ Test box -V.A.G 1598/42- with adapter cable -V.A.G 1598/39-2-
- ♦ Current flow diagram



Note

Other diagnosis testers can be used instead of the vehicle diagnosis, testing and information system.

Test prerequisites

- Fuses must be OK.
- The battery voltage must be at least 11.5 V.
- All electrical consumers must be switched off.
- Earth connection OK.
- Engine must be cold

Test procedure



Note

Only gold-plated contacts may be used when repairing the exhaust gas temperature sender 3 connector contacts.

- Connect vehicle diagnosis, testing and information system -VAS 5051- and select diagnosis function "011-Read data block". the engine must be idling when doing so. (Connect vehicle diagnosis, testing and information system and select engine control unit ⇒ [page 3](#)).
- Select "Display group 99".

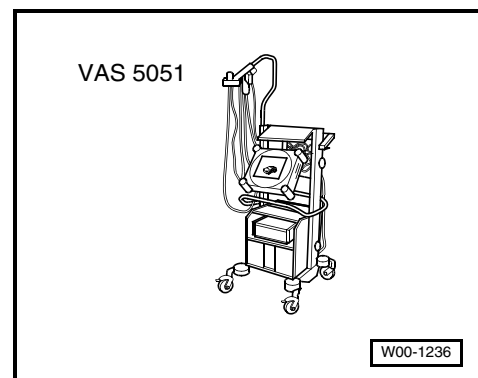



Indicated on display:

Display group 99			
880 rpm	114.0 °C	xxx.x °C	xxx.x °C

i Note

On the display of the vehicle diagnosis, testing and information system -VAS 5051- the display zones are displayed below one another and, next to one another on other diagnosis testers.

- Increase engine speed to 2400...2800 rpm.
- Check exhaust gas temperature value for exhaust gas temperature sender 1 -G235- (exhaust gas temperature sender before turbocharger) in display zone 2. The temperature value must increase uniformly and without interruption.
- Hold engine speed at 2400...2800 rpm for approx. 3 minutes.

i Note

Note temperature value in display zone 2.

- Press key.
- Select, at an increased engine speed, "Display group 100".

Indicated on display:

Display group 100			
xxx °C	xxx °C	xxx mbar	xxx mbar

- Check exhaust gas temperature value of exhaust gas temperature sender 3 -G495- (exhaust gas temperature sender before particulate filter) in display zone 1 and of exhaust gas temperature sender 4 -G648- (exhaust gas temperature sender after particulate filter) in display zone 2.

i Note

- ◆ *The exhaust gas temperature in display zone 2 of display group 99 must be higher than exhaust gas temperature values in display zones 1 and 2 of display group 100.*
- ◆ *The exhaust gas temperature in display zone 1 of display group 100 must also be higher than exhaust gas temperature value in display zone 2 of display group 100.*

- If, in display group 100, the value of display zone 2 is higher than value in display zone 1, both senders are interchanged.
- If in display zone 2 in display group 99 no realistic display is shown, check exhaust gas temperature sender 1 -G235- (exhaust gas temperature sender before turbocharger) and wiring to sender as follows:
 - Terminate diagnosis function.
 - Switch off ignition.

Checking resistance

- Disconnect 2-pin connector for exhaust gas temperature sender 1 -G235- ⇒ **item 11 on page 185.**



- Connect multimeter to measure resistance at contacts to sender using auxiliary cables from -V.A.G 1594-. Specification: 170.0...850.0 Ω .

If the specification is not attained:

- Renew exhaust gas temperature sender 1 -G235-
⇒ [page 184](#), Assembly overview - turbocharger with attachments.
- Then read fault memory of engine control unit and clear fault memory if necessary ⇒ [page 7](#), Clearing fault memory.

If specification is attained:

- Check exhaust gas temperature sender 1 -G235- wiring as follows:
- Connect test box -V.A.G 1598/42- to control unit wiring harness ⇒ [page 5](#) using adapter cable -V.A.G 1598/39-2-. The engine control unit is not connected by this action.
- Check wiring between test box and connector for open circuit referring to current flow diagram.
- ◆ Contact 1 + socket 89
- ◆ Contact 2 + socket 9
- Wire resistance: max. 2.0 Ω
- Also check wiring for short to one another, to battery earth/engine earth and to battery positive. Specification: ∞ Ω .

If no fault in lines is detected:

- Renew engine control unit -J623- ⇒ [page 259](#).

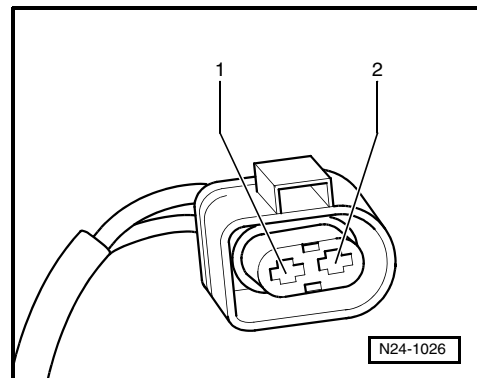
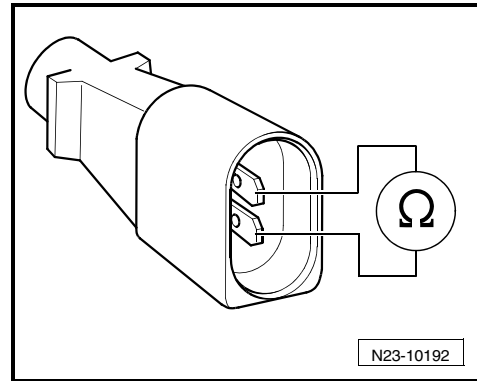



23 – Mixture preparation - injection

1 Repairing diesel direct injection system

The engine control unit -J623- is equipped with a fault memory. Before and after repairs, adjustments and fault finding, the fault memory must be read ⇒ [page 7](#) and final control diagnosis carried out.

 **Note**

- ◆ *During some checks, it is possible that the engine control unit will detect and store a fault. Therefore, after completing all checks and repairs, read the fault memory and erase if necessary ⇒ [page 7](#), Reading fault memory.*
- ◆ *For trouble-free operation of electrical components, a voltage of at least 11.5 V is necessary.*
- ◆ *Renew self-locking nuts.*

Observe safety precautions when working on diesel direct injection fuel system ⇒ [page 208](#).

Observe rules for cleanliness ⇒ [page 208](#).

Assembly overview - intake manifold with attachments ⇒ [page 209](#).

Removing and installing intake manifold ⇒ [page 210](#).

System layout ⇒ [page 211](#).

Assembly overview - fuel system ⇒ [page 213](#).

Removing and installing injector (piezo injector) ⇒ [page 216](#).

Installing high-pressure pipes ⇒ [page 219](#).

Checking return flow rate from fuel pressure regulating valve -N276- ⇒ [page 220](#).

Removing and installing fuel pressure regulating valve -N276- ⇒ [page 221](#).

Removing and installing fuel pressure sender -G247- ⇒ [page 222](#).

Removing and installing high-pressure pump ⇒ [page 224](#).

Filling/bleeding fuel system ⇒ [page 226](#).

Checking fuel system for leaks ⇒ [page 227](#).

Checking pressure retention valve in fuel return line ⇒ [page 228](#).



1.1 Safety precautions when working on diesel direct injection fuel system



WARNING!

Due to the cramped conditions, note the following when carrying out repairs:

- ◆ *Route all the various lines (e.g. for fuel, hydraulics, activated charcoal filter system, coolant, refrigerant, brake fluid and vacuum) and electrical wiring in their original positions.*
- ◆ *Ensure that there is sufficient clearance to all moving or hot components.*

To prevent injuries to persons and/or damage to the injection and glow plug system, the following must be noted:

- ◆ Always switch off the ignition before connecting or disconnecting injection and glow plug system wiring or tester cables.
- ◆ If the engine is to be turned at starter speed without starting, e.g. to check compressions, pull off connector -A- from injectors.
- ◆ Disconnecting and connecting the battery must only be done with the ignition switched off, otherwise the engine control unit could be damaged.

Observe following if test and measuring instruments are required during a road test:

- ◆ Test and measuring instruments must be secured and operated by a second person.

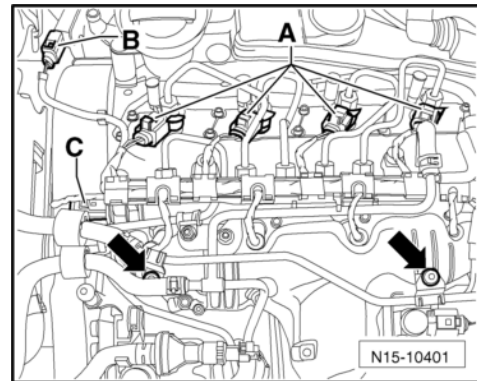

1.2 Rules for cleanliness

The following "rules" for cleanliness are to be carefully heeded when working on the fuel supply/injection system:

- ◆ Thoroughly clean all unions and adjacent areas before disconnecting.
- ◆ Place removed parts on a clean surface and cover. Use only lint-free cloths!
- ◆ Carefully cover opened components or seal if repairs cannot be carried out immediately.
- ◆ Only install clean components: Only unpack replacement parts immediately prior to installation. Do not use parts that have not been stored in their packing (e.g. in tool boxes etc.).
- ◆ Existing transport and protective packaging and sealing caps must only be removed immediately prior to installation.
- ◆ When system is open: Avoid working with compressed air if possible. Do not move vehicle unless absolutely necessary.
- ◆ Also ensure that no diesel fuel comes into contact with the coolant hoses. If necessary, the hoses must be cleaned immediately. Damaged hoses must be renewed.

1.3 Assembly overview - intake manifold with attachments

- Note safety precautions before beginning work
⇒ page 208.
- Observe rules for cleanliness ⇒ page 208.

Removing and installing intake manifold ⇒ page 210.

1 - Intake manifold

- Must not be taken apart
- Removing and installing
⇒ page 210.

2 - 8 Nm

3 - Gasket

- Renew.

4 - Seal

- Renew.

5 - Connecting pipe

- To exhaust gas recirculation cooler.

6 - 20 Nm

7 - Gasket

- Renew.

8 - 8 Nm

9 - Throttle valve module -J338-

- Checking
⇒ page 47, final control diagnosis

10 - 8 Nm

11 - Connection

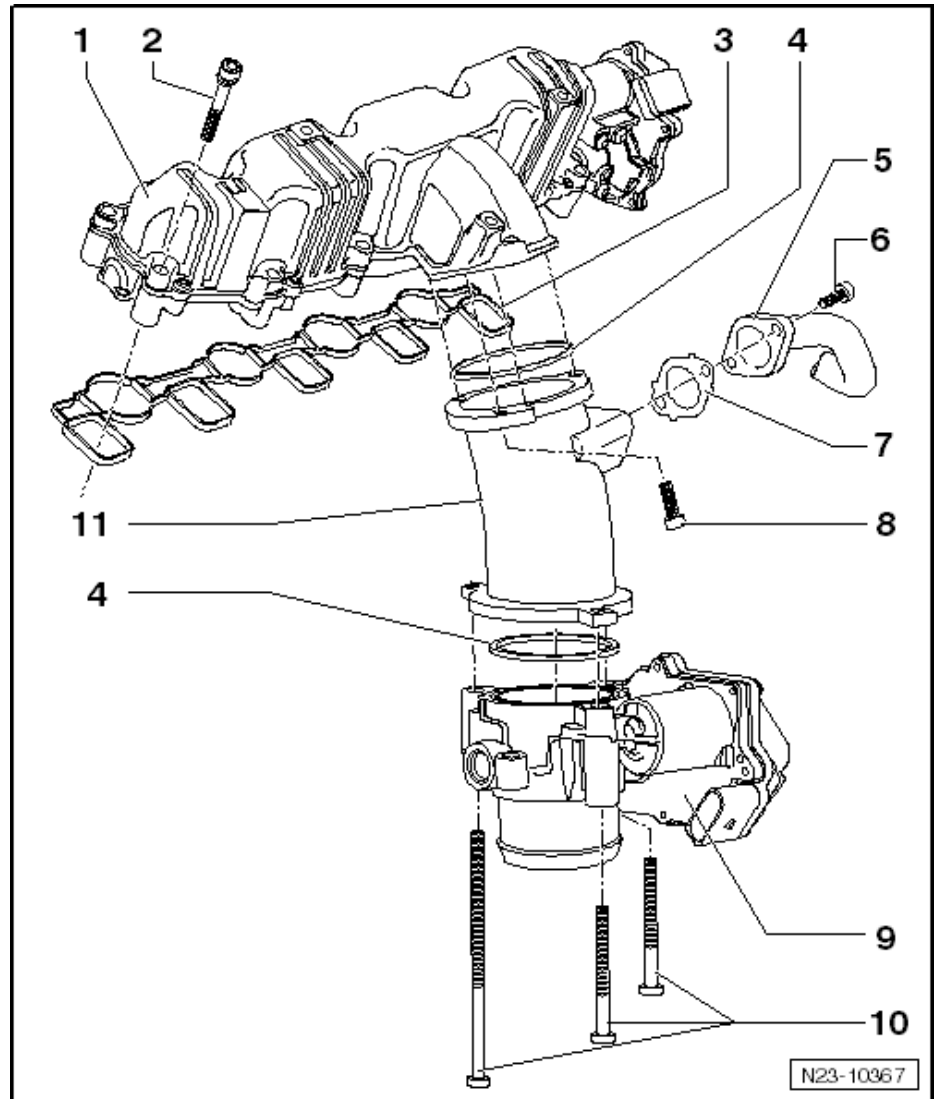



1.3.1 Removing and installing intake manifold

Special tools and workshop equipment required

- ◆ Torque wrench -V.A.G 1331-

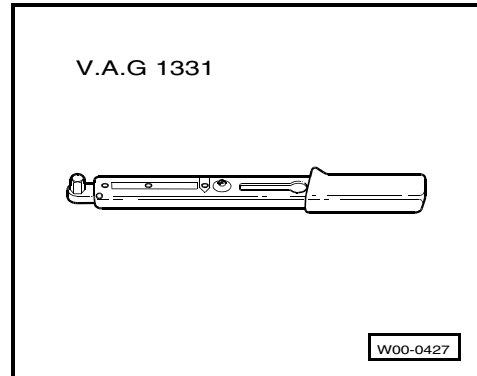

- ◆ Allen key, long reach -T40159-

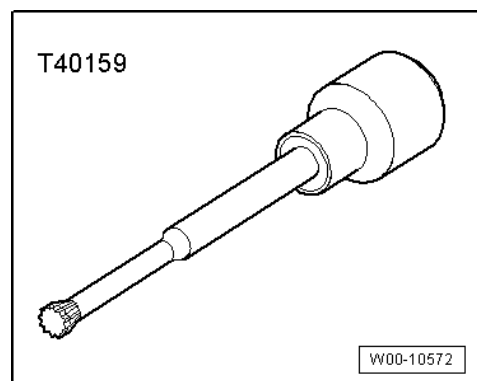

- ◆ Pliers -3314-

Removing

⚠ Caution!

Ensure that no cable connections are damaged when pulling off connectors. Otherwise the complete wiring harness must be renewed. Do not compress the pliers -3314- to firmly to separate the connectors, otherwise the support sleeve may be damaged.

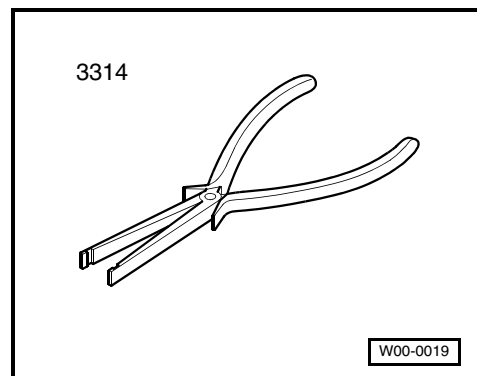

- Position pliers -3314- with groove -arrow A- on support sleeve shoulder -arrow B-.

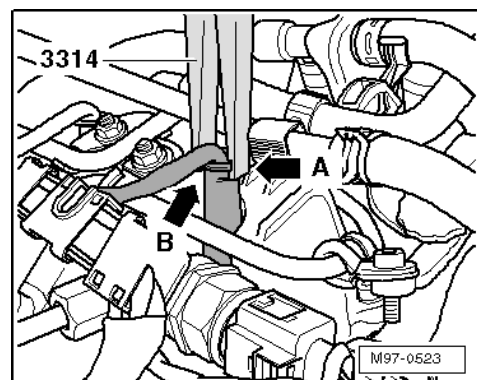



- Carefully pull connector off glow plug in direction of -arrow-.
- Pull fuel return lines off fuel rail, injectors and high-pressure pump.

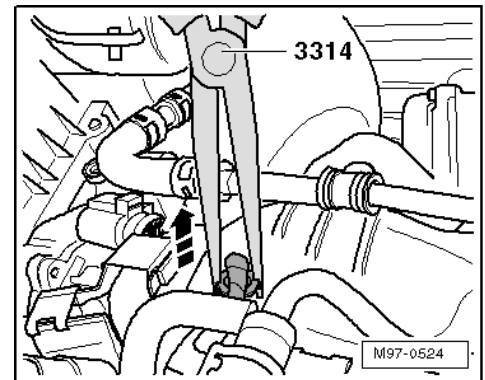

- Unscrew securing bolt -arrow- and remove fuel return line.
- Remove high-pressure line between high-pressure pump and common rail.

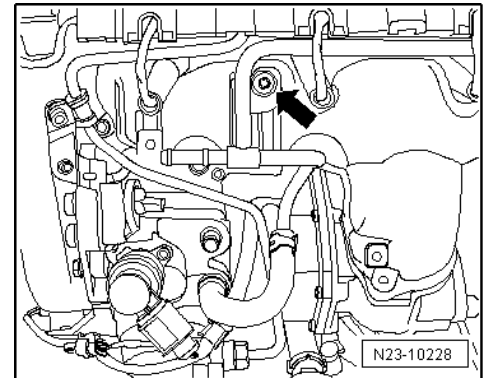

- Pull connector -2- off throttle valve module -J338-.
- Unfasten clamp -4- and pull off charge air hose.
- Remove bolts securing intake manifold in diagonal sequence starting from outside and working inwards using socket set -T40159-.
- Remove intake manifold from engine.

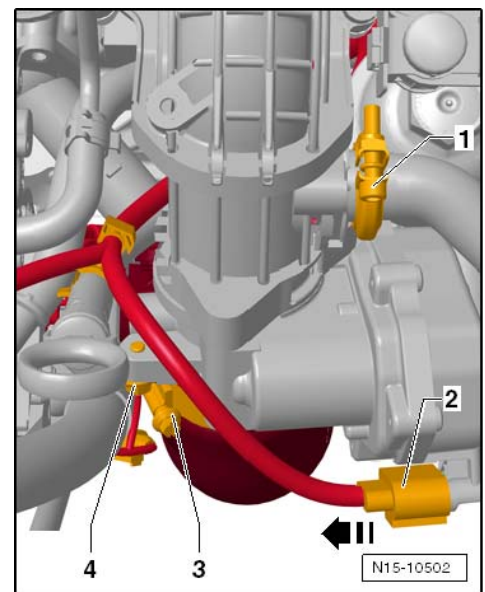

Installing

Installation is carried out in the reverse order. When installing, note the following:

- Renew seals and/or gaskets.
- Tighten bolts securing intake manifold in diagonal sequence starting from inside and working outwards. Specified torque ⇒ [item 2 on page 209](#).

1.4 System layout

WARNING!

- ♦ **Always read rules for cleanliness and instructions when working on fuel system ⇒ [page 208](#).**
- ♦ **Always follow these rules for cleanliness and instructions before starting work and while working on the fuel system.**
- ♦ **If components of the fuel system between the tank and the high-pressure fuel pump are removed or renewed, the fuel system must be filled to be bled ⇒ [page 226](#). (It is important not to allow the high-pressure pump to run while still empty.)**

1 - Fuel tank

- With fuel system pressurisation pump -G6- (when fitted).

2 - Fuel filter

- With pre-heating valve.
- Fuel filter - exploded view ⇒ [page 173](#)

3 - Supplementary fuel pump -V393-

- Removing and installing ⇒ [page 177](#).
- Checking ⇒ [page 179](#).

4 - Filter sieve

5 - Fuel temperature sender -G81-

- Checking ⇒ [page 251](#).

6 - High-pressure pump

- After renewing, first fuel filling MUST be performed (it is important not to allow pump to run while it is still empty) ⇒ [page 226](#)
- Removing and installing ⇒ [page 224](#).

7 - Fuel metering valve -N290-

- Must not be removed.
- Checking ⇒ [page 229](#).

8 - Fuel pressure regulating valve -N276-

- Checking fuel pressure regulating valve ⇒ [page 232](#)
- Checking return flow rate ⇒ [page 220](#).
- Removing and installing ⇒ [page 221](#).

9 - High-pressure accumulator (rail)

10 - Fuel pressure sender -G247-

- Removing and installing ⇒ [page 222](#).
- Checking ⇒ [page 235](#).

11 - Pressure retention valve

- The pressure retention valve maintains a residual pressure of approx. 10 bar in the return lines.
- This residual pressure is required for the control function of the piezo injectors.
- The pressure retention valve may only be renewed together with the fuel return lines.
- After replacement, engine must be run at idling speed for approx. 2 minutes to bleed fuel system.
- Check pressure retention valve ⇒ [page 228](#).

12 - Injectors (piezo injectors)

- Injector, cylinder 1 -N30-
- Injector, cylinder 2 -N31-
- Injector, cylinder 3 -N32-

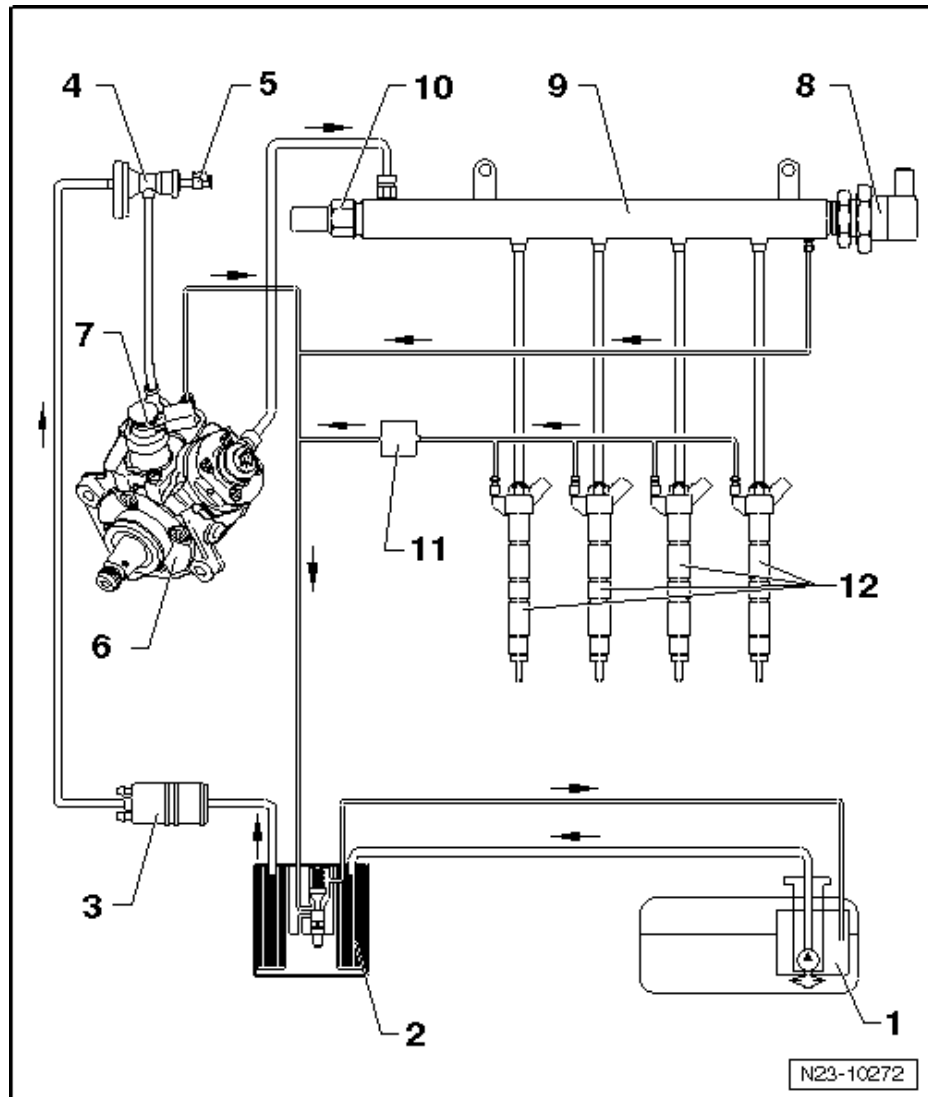



- Injector, cylinder 4 -N33-
- Removing and installing ⇒ [page 216](#).
- Checking ⇒ [page 241](#).

1.5 Assembly overview - fuel system

WARNING!

- ◆ *Always read rules for cleanliness and instructions when working on fuel system ⇒ [page 208](#).*
- ◆ *Always follow these rules for cleanliness and instructions before starting work and while working on the fuel system.*

To prevent the high-pressure fuel pump from running while it is empty and to ensure that the engine starts quickly after parts have been renewed, it is important to observe the following:

- ◆ If components of the fuel system between the fuel tank and the high-pressure fuel pump are removed or renewed, the fuel pump must be actuated by the final control diagnosis to bleed the fuel system.
- ◆ If a fuel pump, fuel line or fuel filter are removed or renewed, the fuel pump must be actuated by the final control diagnosis for at least 60 seconds before the engine is started for the first time.
- ◆ If the fuel pump is removed or renewed, the fuel pump must be actuated by the final control diagnosis for at least 180 seconds before the engine is started for the first time.

Caution!

Adhere strictly to rules of cleanliness. No dirt must be allowed to get into the disconnected fuel return lines or the open connections on the injectors.

Protect open fuel connections from dirt entrainment using suitable methods under all circumstances.



- 1 - 8 Nm
- 2 - High-pressure line, 28 Nm

- Between high-pressure pump and high-pressure accumulator (common rail)

- 3 - Fuel return lines

- With pressure retention valve
- Check pressure retention valve ⇒ page 228.
- Note various versions ⇒ Fig. on page 216.

- 4 - 8 Nm

- 5 - High-pressure lines, 28 Nm

- Between high-pressure accumulator (common rail) and injectors

! Caution!

The high-pressure lines may be re-used after the following checks:

- ◆ Check taper seat of respective high-pressure line for deformation and cracks.
- ◆ The bore of the pipe must not be distorted, restricted or otherwise damaged.
- ◆ Corroded lines should no longer be used.

- Do not interchange.

- Installing free of stress ⇒ page 219

- 6 - Fuel pressure regulating valve -N276-, 80 Nm.

- Checking return flow rate ⇒ page 220.

- Checking fuel pressure regulating valve ⇒ page 232.

- Removing and installing ⇒ page 221.

- 7 - High-pressure accumulator (rail)

- 8 - Fuel supply line

- 9 - High-pressure pump

- Removing and installing ⇒ page 224.

- 10 - 20 Nm

- 11 - Fuel pressure sender -G247-, 100 Nm

- Removing and installing ⇒ page 222.

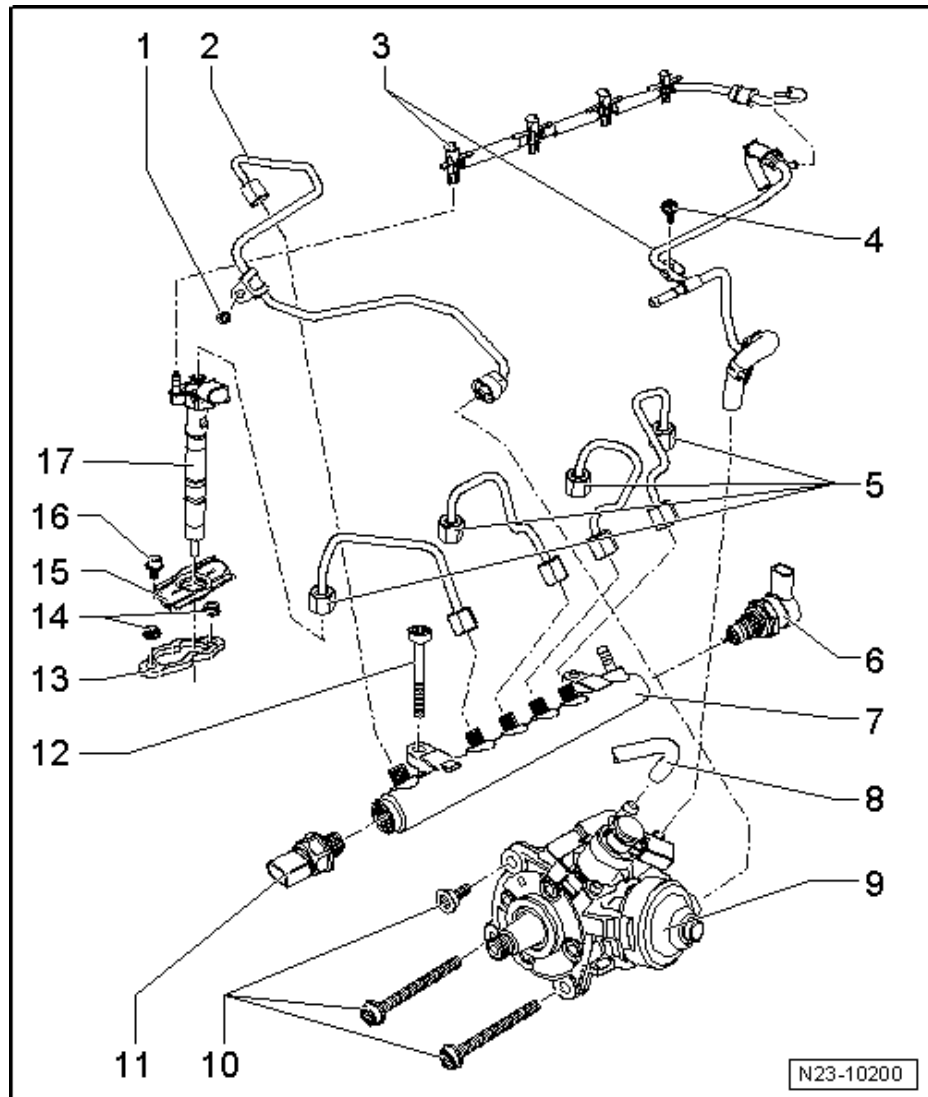



- Checking ⇒ [page 235](#).

12- 22 Nm

13- Clamping piece

- Renew.
- Note installation position ⇒ [Fig.](#)

14- 10 Nm

15- Injector cover

16- 5 Nm

17- Injector (piezo injectors)

- When removing and installing or replacing an injector, always renew the following components and seals/O-rings: "copper seal", "O-ring for injector bore" and "O-ring for injector return connection".
- If they are to be re-installed, the injectors must always be re-fitted in their original positions (i.e. on the same cylinder).
- Before re-using "high-pressure injector pipe", perform visual check of taper seats for damage such as transverse scores or corrosion; always renew if damaged.
- Removing and installing ⇒ [page 216](#).
- Checking ⇒ [page 241](#).

Installation position of clamping piece

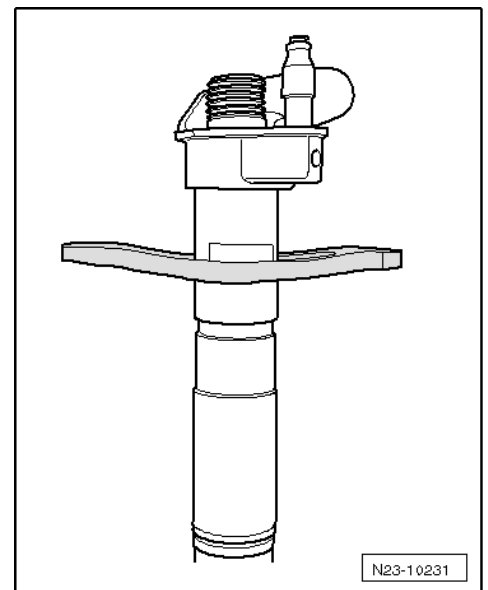



Differences on fuel return line

-A-, no rifled section: use clamp according to ⇒ ETKA (Electronic parts catalogue) to connect overflow oil line.

-B-, with rifled section: DO NOT use a clamp to connect overflow oil line.

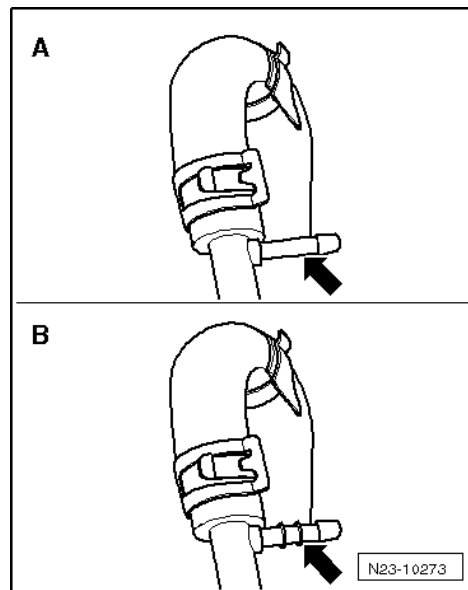

1.6 Removing and installing injector (piezo injector)

Special tools and workshop equipment required

- ◆ Puller -T10055-
- ◆ Assembly sleeve -T10377-
- ◆ Socket -T40055-
- ◆ Torque wrench -V.A.G 1331-
- ◆ Ratchet -V.A.G 1331/1-

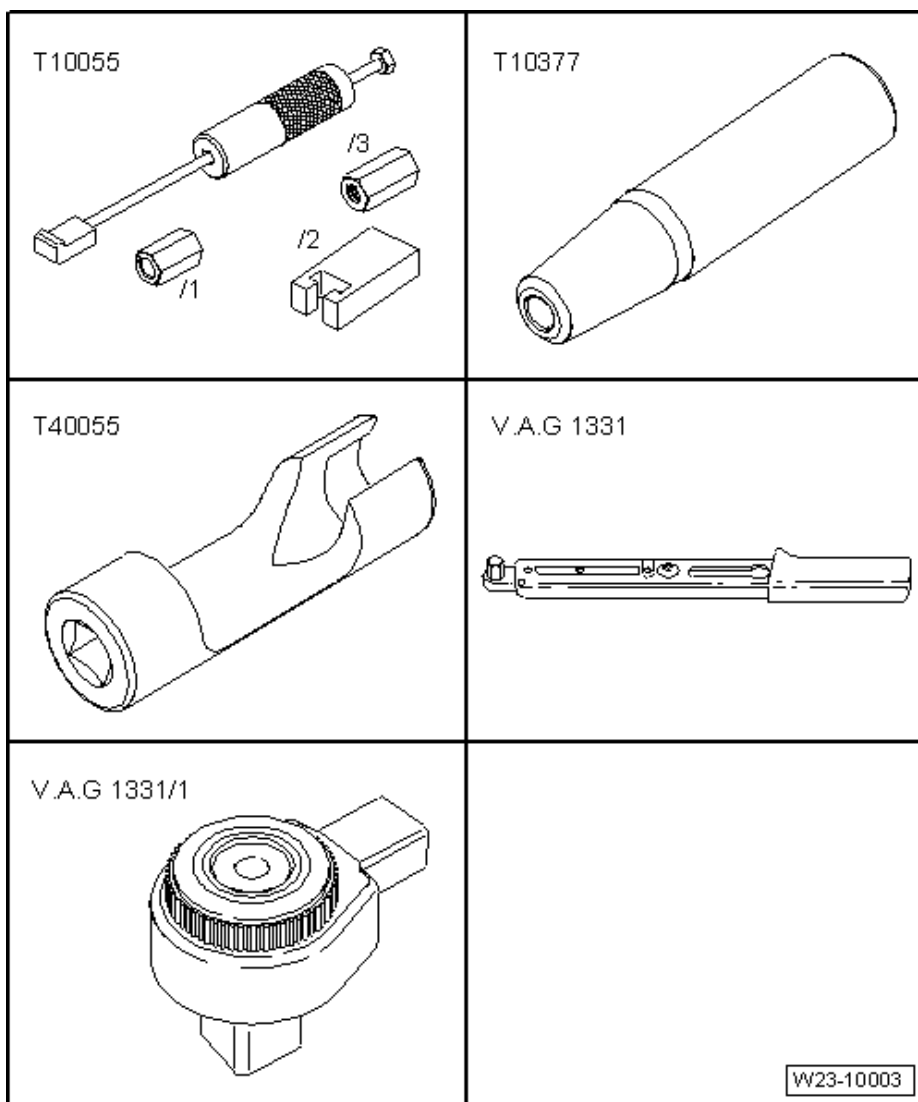



1.6.1 Removing

- Take noise insulation off cylinder head cover.
- Disconnect connector -1- from injectors to be removed.

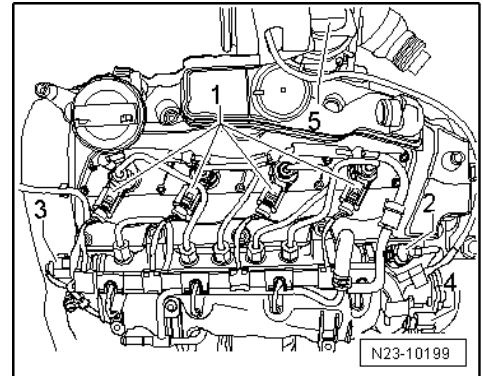

- Pull fuel return line connections off injectors to be removed. To do this, push down connection at tabs and pull up centre piece to release.

⚠ **Caution!**

Adhere strictly to rules of cleanliness. No dirt must be allowed to get into the disconnected fuel return lines or the open connections on the injectors.

Protect open fuel connections from dirt entrainment using suitable methods under all circumstances.

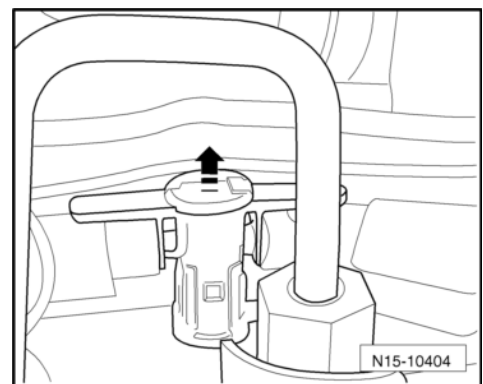

i **Note**

- Unscrew high-pressure line ⇒ **item 5 on page 214** between common rail and injectors to be removed.
- Unscrew securing bolts for cover ⇒ **item 15 on page 215** of injectors to be removed.
- Slightly lift cover and turn it 90° to have access to injector securing nuts.

⚠ **Caution!**

When removing securing nuts from injector there is a risk that the relevant nut will fall into the cylinder head. Proceed very carefully to prevent unnecessary dismantling or further damage.

- Unscrew securing nuts from respective injector.



- Apply puller -T10055- with adapter -T10055/1- as shown in illustration and pull injector out upwards by tapping gently.

1.6.2 Installing

Important instructions for installing injectors

- When removing and installing or replacing an injector, always renew the following components and seals/O-rings: "clamping piece", "copper seal", "O-ring for injector bore" and "O-ring for injector return connection".
- Used injectors may only be re-installed on the same cylinder.
- Make sure that the injectors and the installation area are clean before installing.
- The injectors must be completely undamaged.
- Lubricate all O-rings with engine oil or assembly oil before installing.

If a used injector is being re-installed:

- Spray tip of injector nozzle with rust-releasing spray. Wait approx. 5 minutes and wipe off soot particles and oil with a cloth.
- To remove the old copper seal from the injector, clamp the seal carefully in a vice so that it is just held between the jaws without turning. Then carefully pull and twist the injector out of the copper seal by hand.
- Use a plastic bush to fit the new copper seal.
- To prevent damage to the new O-ring -2- for the fuel return line connection, push it over assembly tool -1-.
- To remove carbon deposits from the injector sealing surface, clean the injector seat in the cylinder head with a cloth soaked in engine oil or rust solvent. Take care not to damage the sealing surface when doing this.

- Renew O-ring for injector bore using assembly sleeve -T10377-.
- Fit injector cover.
- Slide clamping piece onto injector and note its installation position ⇒ [Fig. on page 215](#).
- Insert injector into injector bore.

⚠ Caution!

When removing securing nuts from injector there is a risk that the relevant nut will fall into the cylinder head. Proceed very carefully to prevent unnecessary dismantling or further damage.

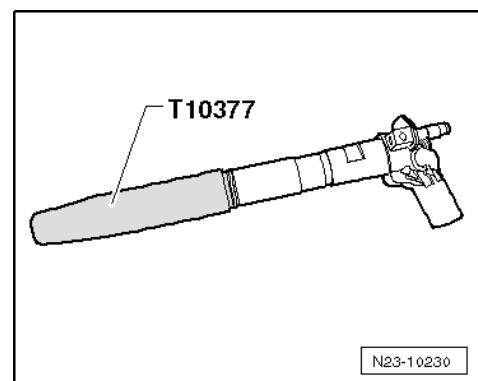
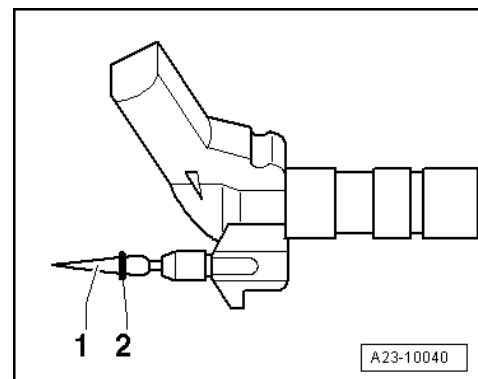
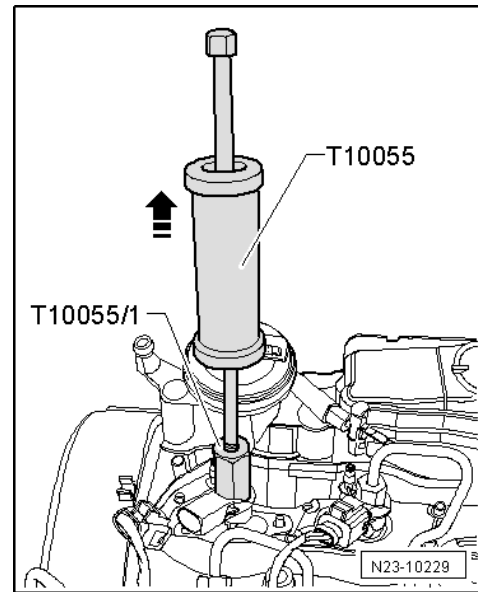



- Carefully position securing nuts of clamping piece by hand and tighten. Specified torque ⇒ [item 14 on page 215](#).
- Turn injector cover onto installation position and bolt. Specified torque ⇒ [item 16 on page 215](#).
- Install high-pressure lines ⇒ [page 219](#).

i Note

After replacement of one or more injectors, the “injector delivery calibration values (IDC)” and “injector voltage calibration values (IVC)” for the new injectors must be written into the engine control unit ⇒ [page 261](#).

1.6.3 Installing high-pressure pipes

Special tools and workshop equipment required

- ◆ Torque wrench -V.A.G 1331-

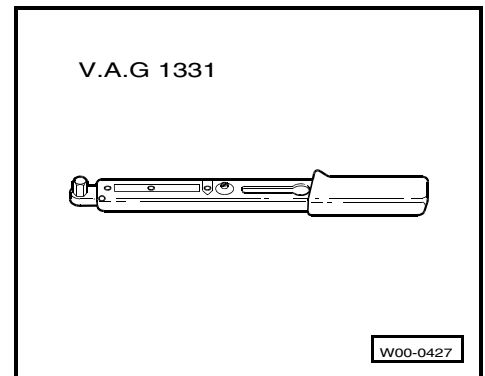

- ◆ Socket -T40055-

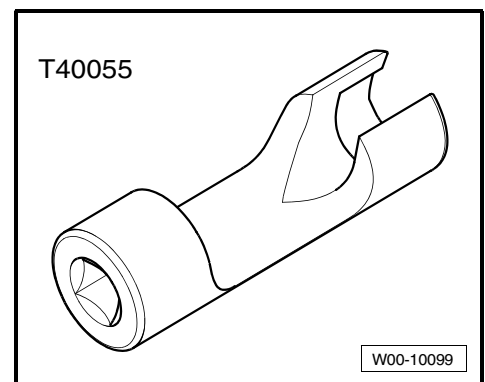

! Caution!

To ensure the injector lines are fitted free of stress, loosen rail and, if necessary, move rail slightly. The lines must never be bent or tensioned. Stress may cause the respective line to break in the long-term.

i Note

This section describes how to install new injection lines. If you wish to re-use existing injection lines, you must check the points listed under ⇒ [item 5 on page 214](#). Apart from that the procedure is identical.

Installing individual injection lines (cylinder 1 to 4, between fuel rail and injector)

- Unpack new injection line. Remove sealing plugs and place line directly in position between fuel rail and injector.
- Tighten union nuts on injection line hand-tight without any tool to start with. Ensure that line correctly gets into its seat.
- If necessary, proceed in the same way with other injection lines.



- Retighten fuel rail if necessary. Specified torque ⇒ **item 12 on page 215**.
- Tighten union nuts of all new injection lines using torque wrench -V.A.G 1331- and socket bit -T40055-. Specified torque ⇒ **item 5 on page 214**.

Installing fuel line (between high-pressure pump and fuel rail) or a complete set of lines

- If it has not been done yet, loosen securing bolts of fuel rail and ensure that fuel rail can be moved.
- Unpack fuel line between high-pressure pump and rail. Remove sealing plugs and place line directly in position.
- Tighten union nuts on injection line hand-tight without any tool to start with. Ensure that line correctly gets into its seat.
- If complete set of lines must be installed, proceed in the same way with the 4 injection lines.
- Slide all 3 securing clamps over fuel line and observe alignment.
- Screw in clamp securing bolts about 3 turns.
- Retighten fuel rail. Specified torque ⇒ **item 12 on page 215**.
- Tighten securing clamp at top of intake manifold to 8 Nm.

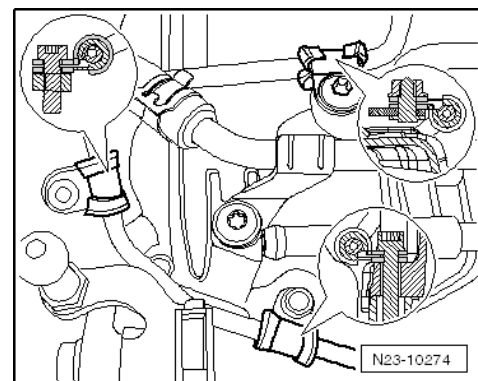
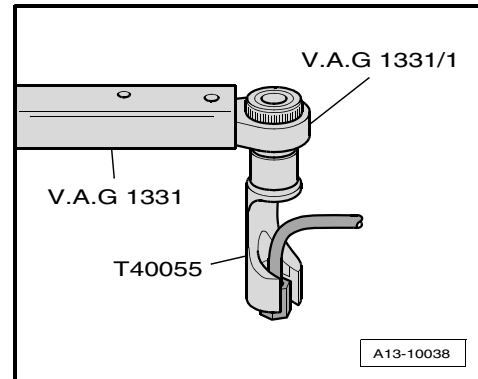

- Tighten union nuts of all new injection lines using torque wrench -V.A.G 1331- and socket bit -T40055-. Specified torque ⇒ **item 5 on page 214**.
- Now tighten remaining 2 securing clamps to 8 Nm.
- Press return line connections carefully over seals and onto injectors (check seal for damage). The fastener must engage audibly. Then carefully press down the release pin.
- Filling fuel system ⇒ **page 226**.

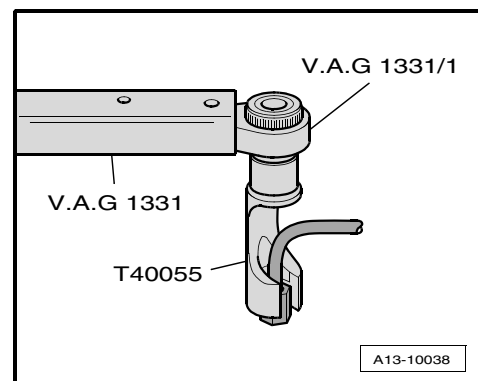

1.7 Checking return flow rate from fuel pressure regulating valve -N276-



WARNING!

- ♦ **Always read rules for cleanliness and instructions when working on fuel system ⇒ **page 208**.**
- ♦ **Always follow these rules for cleanliness and instructions before starting work and while working on the fuel system.**

- Take noise insulation out of injectors.



- Pull off fuel return line -1-.

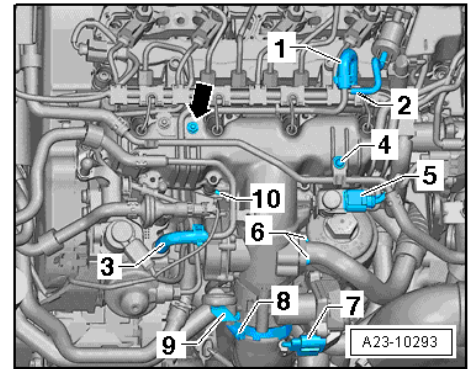

- Seal open fuel return line connection with a blanking plug -1-.
- Connect fuel return line -2- to suitable hose -3-.
- Hold end of this hose in a suitable container to measure the return flow rate.
- Start engine and run at idling speed.
- Specification after 5 to 10 seconds: return flow rate = 0 ml

If the specification is not attained, the fuel pressure regulating valve -N276- is defective.

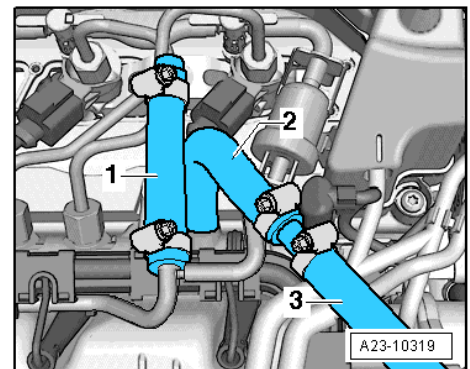

1.8 Removing and installing fuel pressure regulating valve -N276-

Fuel pressure regulating valve is located in high-pressure accumulator. The valve maintains a constant pressure in high-pressure accumulator and injector lines (high-pressure fuel circuit).

Regulating valve opens when fuel pressure in high-pressure circuit is too high. Some of the fuel from the high-pressure accumulator is then returned to the fuel tank via the return line.

The regulating valve closes when fuel pressure in high-pressure circuit is too low. The valve seals the high-pressure side from the low-pressure side.

⚠ **Caution!**

Always read rules for cleanliness and instructions when working on fuel system ⇒ page 208.

Follow these instructions before starting work and while working on the fuel system.

- Clean threaded area around regulating valve (e.g. with standard cleaning solution) before removing. Dirt/contamination must never enter hole in high-pressure accumulator (rail element).



 **Note**

- ◆ *Clean carefully; cleaning solvent must not enter the electrical connector.*
- ◆ *The fuel pressure regulating valve -N276- cannot be re-used.*
- Dry off fuel pressure regulating valve -N276-.
- Detach electrical connector at fuel pressure regulating valve -N276-.
- Counterhold at housing hexagon and loosen union nut. Then unscrew and remove by hand.
- Extract dirt from high-pressure accumulator bore (threads and sealing surface). Do not use metal tools, etc.

 **Note**

Seal off high-pressure accumulator hole immediately with a suitable plug to prevent dirt from entering.

Installing

 **Note**

- ◆ *Check that sealing surfaces (deformable sealing lip) and threads on fuel pressure regulating valve -N276- are undamaged.*
- ◆ *Also check sealing surface at high-pressure accumulator bore.*
- ◆ *Thread on fuel pressure regulating valve -N276- must be free of oil and grease.*
- Screw on union nut by hand.
- Align fuel pressure regulating valve -N276- so that connecting wire is free of mechanical tension after electrical connector is attached.
- Counterhold at housing hexagon and tighten union nut. Specified torque ⇒ [item 6 on page 214](#)
- After installation, run engine at moderate speed for several minutes and then switch off.
- Check fuel system for leaks ⇒ [page 227](#).
- Then read fault memory of engine control unit and clear fault memory if necessary ⇒ [page 7](#), Clearing fault memory.
- Then carry out a road test/trial run with at least one full-power acceleration. Then check high-pressure part of fuel system again for leakage.
- Finally, read fault memory of engine control unit again ⇒ [page 7](#), Reading fault memory.

1.9 Removing and installing fuel pressure sender -G247-

The fuel pressure sender -G247- (rail pressure sensor) is located in the high-pressure accumulator and continuously meas-



ures the current fuel pressure in the high-pressure system. It transmits a corresponding voltage signal to the diesel direct injection system control unit -J248-.

Should the sender fail, the engine control unit will control the pressure via a mapped open-loop backup function.

Removing

Caution!

Always read rules for cleanliness and instructions when working on fuel system ⇒ page 208.

Follow these instructions before starting work and while working on the fuel system.

- Clean threaded area around sender (e.g. with standard cleaning solution) before removing. Dirt/contamination must never enter hole in high-pressure accumulator.

Note

Clean carefully; cleaning solvent must not enter the electrical connector.

- Dry off fuel pressure sender -G247-.
- Disconnect electrical connector at fuel pressure sender -G247-.
- Unscrew and remove fuel pressure sender -G247-.
- Extract dirt from high-pressure accumulator bore (threads and sealing surface). Do not use metal tools, etc.

Note

Seal off high-pressure accumulator bore immediately with a suitable plug to prevent dirt from entering.

Installing

Note

- ◆ *Check that sealing surfaces (deformable sealing lip) and threads on fuel pressure sender -G247- are undamaged.*
- ◆ *Also check sealing surface at high-pressure accumulator bore.*
- ◆ *Thread of fuel pressure sender -G247- is coated in a low-friction paint. Therefore thread must be free of oil and grease.*
- Screw in fuel pressure sender -G247- by hand.
- Tighten sender. Specified torque ⇒ **item 11 on page 214**
- After installation, run engine at moderate speed for several minutes and then switch off.
- Check fuel system for leaks.
- Then read fault memory of engine control unit and clear fault memory if necessary ⇒ **page 7**, Clearing fault memory.



- Then carry out a road test/trial run with at least one full-power acceleration. Then check high-pressure part of fuel system again for leakage.
- Finally, read fault memory of engine control unit again
⇒ page 7, Reading fault memory.



1.10 Removing and installing high-pressure pump

⚠ Caution!

- ♦ *Running when dry may destroy high-pressure pump.*
- ♦ *The high-pressure pump must first be filled with fuel before the engine is started ⇒ page 226. (It is important not to allow the high-pressure pump to run while still empty.)*
- ♦ *Protect open fuel connections from dirt entrainment using suitable methods under all circumstances.*

Special tools and workshop equipment required

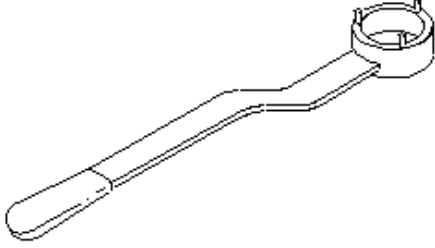
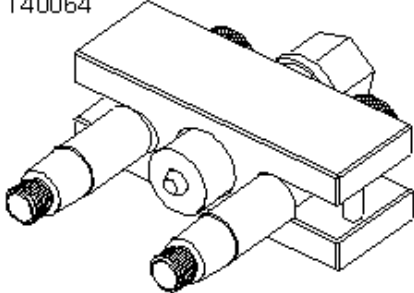
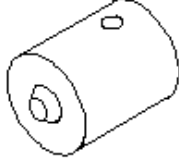
- ♦ Counterhold -T10051-
- ♦ Puller -T40064-
- ♦ Thrust piece -T40064/1-
- ♦ Torque wrench -V.A.G 1331-

<p>T10051</p> 	<p>T40064</p> 
<p>T40064/1</p> 	<p>V.A.G 1331</p> 
	<p>VW23-10004</p>



- ◆ Pliers -3314-

Removing

- Remove toothed belt from camshaft and high-pressure pump ⇒ [page 117](#).

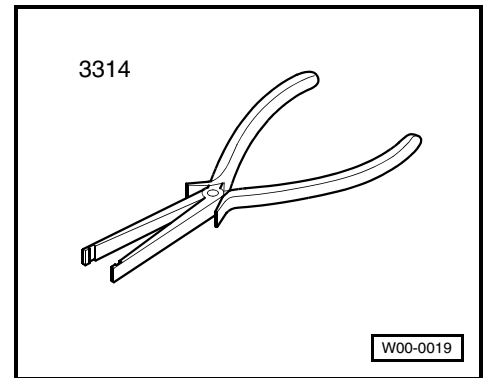

- Disconnect connector -1- and remove bolts -arrows-.

⚠ Caution!

Ensure that no cable connections are damaged when pulling off connectors. Otherwise the complete wiring harness must be renewed. Do not compress the pliers -3314- too firmly to separate the connectors, otherwise the support sleeve may be damaged.

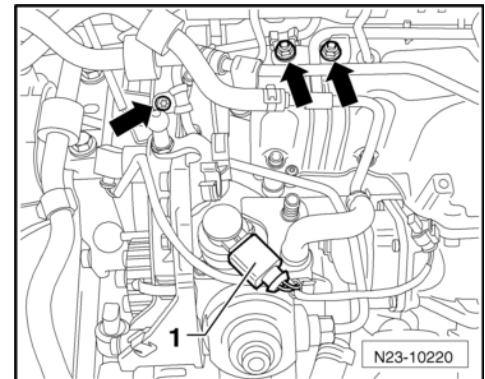

- Position pliers -3314- with groove -arrow A- on support sleeve shoulder -arrow B- and pull plugs off glow pin plugs.

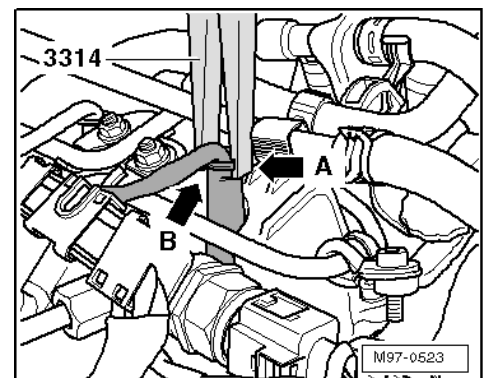

- Carefully pull connector off glow plug in direction of -arrow-.
- Unscrew securing bolts of coolant line from intake manifold and lay coolant line to the side.
- Pull fuel return line off high-pressure pump.
- Pull fuel return line off high-pressure accumulator (fuel rail) and lay it to side.
- Remove fuel supply line between high-pressure pump and high-pressure accumulator (fuel rail).
- Remove toothed belt pulley from high-pressure pump.

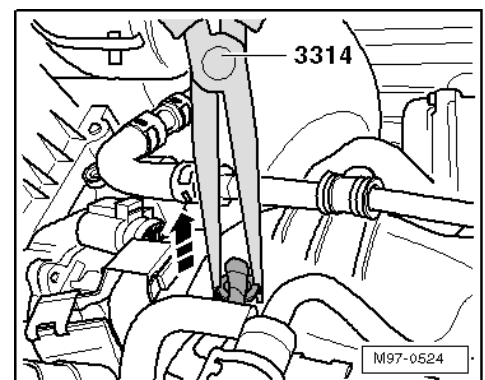



- Counterhold hub of high-pressure pump using counterhold tool -T10051- and unscrew securing nut -1-.

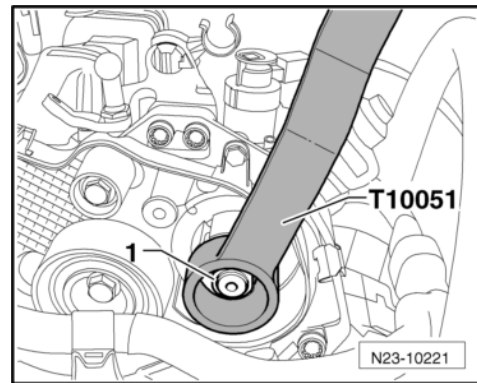

- Apply puller -T40064- with thrust piece -T40064/1- as shown in illustration and pull hub off high-pressure pump. If necessary, counterhold with a 24 mm open-end spanner.

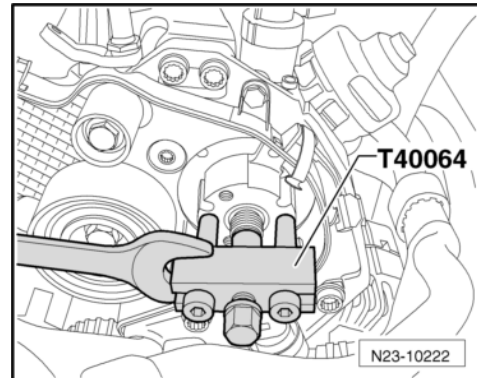

- Unscrew securing bolts -arrows- for high-pressure pump.
- Detach high-pressure pump.

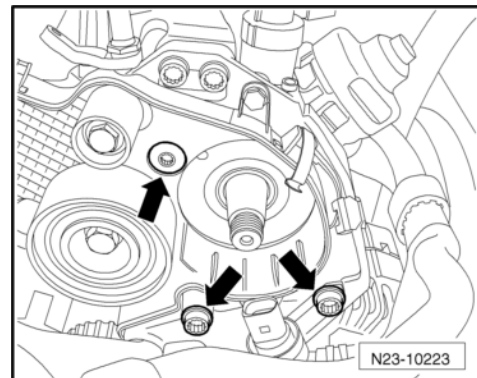

Installing

Installation is carried out in the reverse sequence of removal.

Specified torques for fuel system ⇒ [page 213](#).

Specified torques for toothed belt drive ⇒ [page 80](#).

1.11 Filling/bleeding fuel system

Special tools and workshop equipment required

- ◆ Vehicle diagnosis, testing and information system -VAS 5051- with diagnosis cable -VAS 5051/6A-



Note

Other diagnosis testers can be used instead of the vehicle diagnosis, testing and information system.

Test prerequisites

- Fuses must be OK.
- The battery voltage must be at least 11.5 V.
- All electrical consumers must be switched off.
- Fuel tank: level min "reserve".

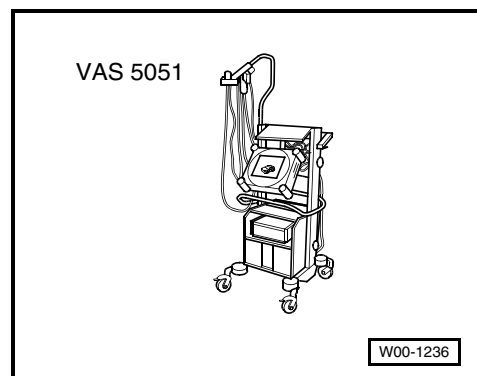



 **Caution!**

After installation, the high-pressure pump must first be filled with fuel before the engine is started (the pump must NOT be allowed to run while still empty).

 **Note**

- ◆ *When installing the high-pressure pump, it is essential to ensure that no dirt enters the fuel system.*
- ◆ *Only remove sealing plugs immediately prior to installation of fuel lines.*
- ◆ *Fuel tank must be filled.*

Proceed as follows to fill high-pressure pump with fuel:

- Switch on ignition.
- Carry out final control diagnosis and actuate fuel pump for 120 seconds ⇒ [page 47](#), Final control diagnosis.

 **Note**

- ◆ *The fuel pump must be actuated for at least 180 seconds. As the actuation of the fuel pump is limited to 120 seconds, run final control diagnosis a second time.*
- ◆ *To run final control diagnosis a second time, switch ignition on and off again.*
- Carry out final control diagnosis again and actuate fuel pump for 120 seconds.
- Then start engine.
- After filling fuel system, leave engine running at moderate speed for a few minutes and then switch off again.
- Check fuel system for leaks.
- Then read fault memory of engine control unit and clear fault memory if necessary ⇒ [page 7](#), Clearing fault memory.
- Then carry out a road test/trial run with at least one full-power acceleration. Then check high-pressure part of fuel system again for leakage.

 **Note**

If there is any air left in the fuel system, the engine may switch to the backup mode during the road test/trial run. Switch off the engine and clear the fault memory. Then continue road test/trial run.

- Finally, read fault memory of engine control unit again ⇒ [page 7](#), Reading fault memory.

1.12 Checking fuel system for leaks

- Clean all re-installed fuel connections with brake cleaner and then dry them.



- Run engine at idling speed for several minutes (do not press accelerator) and then switch off. Fuel system will bleed itself automatically.
- Check the entire fuel system for leaks.

Renew the affected component if leakage still occurs after tightening to the correct torque.

- Then carry out a road test/trial run with at least one full-power acceleration. Then check high-pressure part of fuel system again for leakage.

 **Note**

If there is any air left in the fuel system, the engine may switch to the backup mode during the road test/trial run. Switch off engine and erase fault memory ⇒ [page 7](#), Reading fault memory. Then continue road test/trial run.

1.13 Checking pressure retention valve in fuel return line

The pressure retention valve maintains a residual pressure of approx. 10 bar in the return lines (control function).

This residual pressure is required for the control function of the piezo injectors.

Special tools and workshop equipment required

- ♦ VAS Pressure gauge -6330-

 **WARNING!**

- ♦ **Always read rules for cleanliness and instructions when working on fuel system ⇒ [page 208](#).**
- ♦ **Always follow these rules for cleanliness and instructions before starting work and while working on the fuel system.**

- Clean return line connection of cylinder no. 1 (e.g. with commercial cleaning solution) before removing.
- Dry return line connection on cylinder 1.
- Cover return line connection on cylinder 1 with a cloth.
- Pull of return line connection at no. 1 cylinder. To do this, push down connection at tabs and pull up centre piece to release.

 **Note**

Adhere strictly to rules of cleanliness. No dirt must be allowed to get into the disconnected fuel return lines or the open connections on the injectors.



- Connect tester for fuel return system -VAS 6330- between return line connection on injector and return line.
- Start engine.
- Check pressure indicated on pressure gauge.
- ◆ Specification: 8...14 bar

If the value does not match the specification, fit a new pressure retention valve.

2 Checking components and functions

The component, functional tests and reference to current flow diagrams ⇒ [page 305](#) are for standard components.

Refer to notes/instructions from respective clients of industrial engines for deviations with components and current flow diagrams.

Checking fuel metering valve -N290- ⇒ [page 229](#).

Checking fuel pressure regulating valve -N276- ⇒ [page 232](#).

Checking fuel pressure sender -G247- ⇒ [page 235](#),

Checking Injectors (cylinders 1...4) -N30...N33- ⇒ [page 241](#).

Checking engine speed sender -G28- ⇒ [page 242](#).

Checking Hall sender -G40- ⇒ [page 245](#).

Checking intake air temperature sender -G42- ⇒ [page 246](#).

Checking coolant temperature sender -G62- ⇒ [page 249](#).

Checking fuel temperature sender -G81- ⇒ [page 251](#).

Checking air mass meter -G70- ⇒ [page 253](#).

Checking throttle valve module -J338- ⇒ [page 255](#).

2.1 Checking fuel metering valve -N290-

Special tools and workshop equipment required

- ◆ Vehicle diagnosis, testing and information system -VAS 5051- with diagnosis cable -VAS 5051/6A-

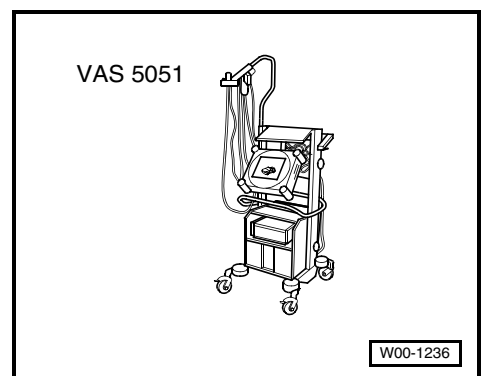
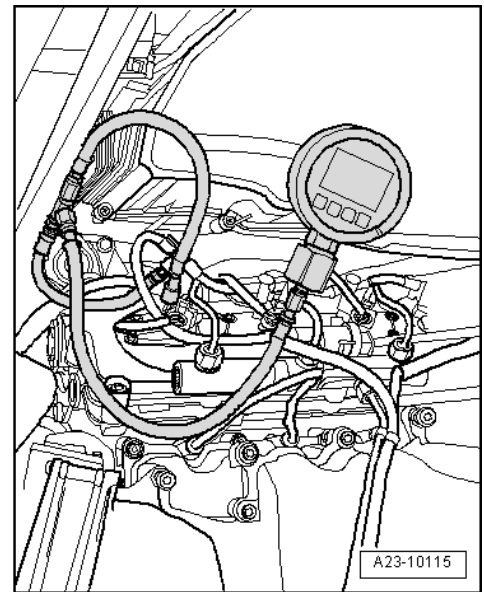



- ◆ K-Jetronic pressure tester -V.A.G 1318-
- ◆ Hand multimeter -V.A.G 1526- or multimeter -V.A.G 1715-
- ◆ Adapter set -V.A.G 1594-
- ◆ Test box -V.A.G 1598/42- with adapter cable -V.A.G 1598/39-1-
- ◆ Current flow diagram

i Note

Other diagnosis testers can be used instead of the vehicle diagnosis, testing and information system.

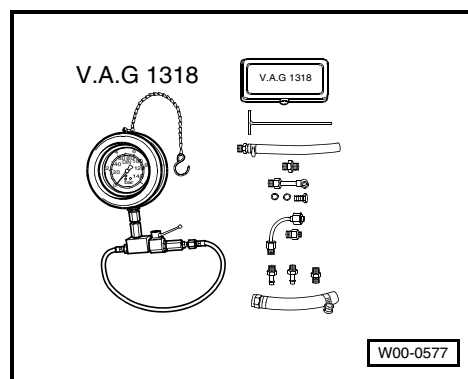

Test prerequisites

- Fuses must be OK.
- Coolant temperature at least 80 °C
- The battery voltage must be at least 11.5 V.
- All electrical consumers must be switched off.
- Earth connection OK.

Test procedure

- Connect vehicle diagnosis, testing and information system -VAS 5051- and select diagnosis function "011-Read data block". the engine must be idling when doing so. (Connect vehicle diagnosis, testing and information system and select engine control unit ⇒ [page 3](#)).

i Note

If the engine does not start, proceed with resistance measurement tests ⇒ [page 231](#).

- Select "Display group 7".

Indicated on display:

Display group 7			
xxx.x °C	xxx.x °C	xxx.x °C	87.3 °C

i Note

On the display of the vehicle diagnosis, testing and information system -VAS 5051- the display zones are displayed below one another and, next to one another on other diagnosis testers.

- Note display zone 4. The coolant temperature must be at least 80 °C for the subsequent test.
- Then check rail pressure as follows:
- Select "Display group 20".

Indicated on display:

Display group 20			
880 rpm	xxxx bar	xxxx bar	xxx.x %

i Note

On the display of the vehicle diagnosis, testing and information system -VAS 5051- the display zones are displayed below one another and, next to one another on other diagnosis testers.



- Check display zones 2 and 3 for rail pressure. In addition, observe duty cycle in display zone 4.

The rail pressure in display zone 2 should be approximately the same as rail pressure in display zone 3, but, not always the same. The pressure difference in display zones 2 and 3 must never be more than 40 bar.

- Display zone 2: Specified high-pressure (fuel): 170...350 bar.
- Display zone 3: Actual high-pressure (fuel): 170...350 bar.
- Display zone 4: Duty cycle (specified): 15...30 %

If the figures in display zones 2 and 3 are OK, and the pressure differential is not greater than 40 bar:

No fault is evident.

- Then read fault memory of engine control unit and clear fault memory if necessary ⇒ [page 7](#), Clearing fault memory.

If a substitute value of 360 bar is displayed in display zones 2 + 3:

- Check fuel pressure sender -G247- ⇒ [page 235](#).

If the specification in display zone 3 is not attained or exceeded:

- First check fuel pressure sender -G247- ⇒ [page 235](#) and fuel pressure regulating valve -N276- ⇒ [page 232](#).

If the pressure differential in display zones 2 + 3 is greater than 40 bar or specified duty cycle in display zone 4 is not attained:

- Switch off ignition.

Checking resistance

Pull connector -1- off fuel metering valve -N290-.

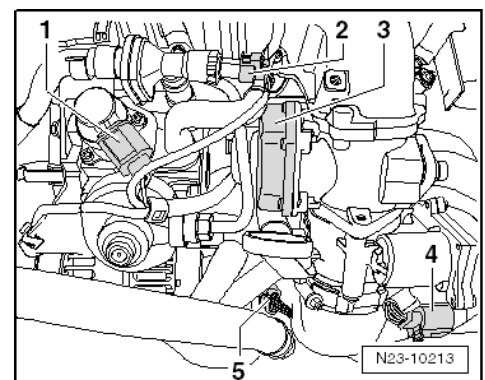



- Connect multimeter to measure resistance at connector contacts 1 + 2 of sender using auxiliary cables from -V.A.G 1594-. Specification: 2.0...5.0 Ω .

If the specification is not attained:

- Renew fuel metering valve -N290-.
- Then read fault memory of engine control unit and clear fault memory if necessary ⇒ [page 7](#), Clearing fault memory.

If specification is attained:

Checking voltage supply

- Check voltage supply of fuel metering valve -N290- as follows:
- Connect multimeter to measure voltage at connector contact 2 and engine earth using auxiliary cables from -V.A.G 1594-.
- Switch on ignition. Specification: At least 11.5 V.
- Switch off ignition.

If the specification is not attained:

- Check cable connections for open circuit, short circuit and transfer resistance at contacts according to current flow diagram.

If specification is attained:

Checking wiring

- Check fuel metering valve -N290- wiring as follows:
- Connect test box -V.A.G 1598/42- to control unit wiring harness ⇒ [page 5](#) using adapter cable -V.A.G 1598/39-1-. The engine control unit is not connected by this action.
- Check wiring between test box and connector for open circuit referring to current flow diagram.
- ◆ Contact 1 + socket 60
- Wire resistance: max. 2.0 Ω
- Additionally check wires for short to one another. Specification: $\infty \Omega$.

If no wiring fault is detected and voltage supply is OK:

- Renew fuel metering valve -N290-.
- Then read fault memory of engine control unit and clear fault memory if necessary ⇒ [page 7](#), Clearing fault memory.

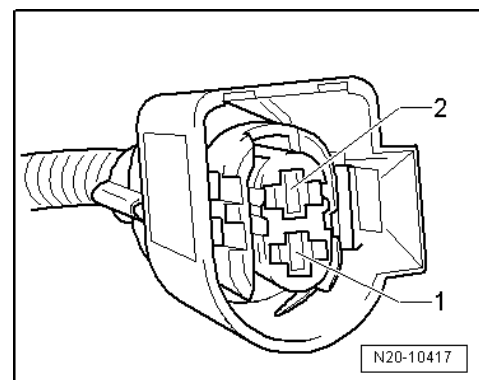
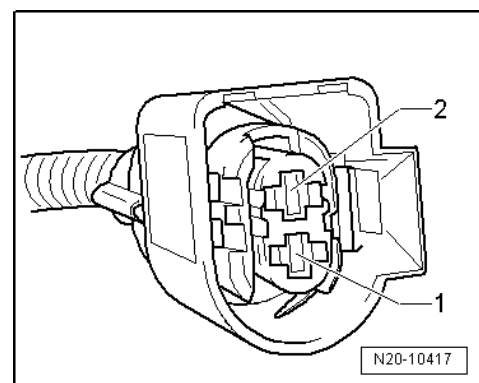
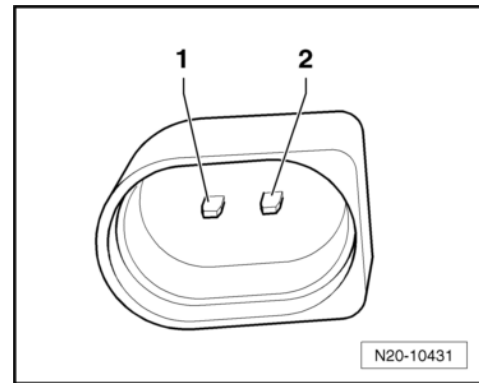

2.2 Checking fuel pressure regulating valve -N276-

Special tools and workshop equipment required



- ◆ Vehicle diagnosis, testing and information system
-VAS 5051- with diagnosis cable -VAS 5051/6A-

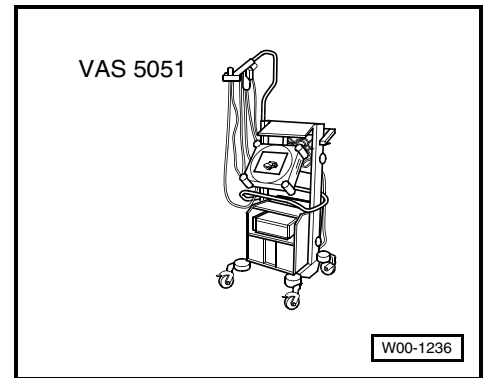

- ◆ K-Jetronic pressure tester -V.A.G 1318-
- ◆ Hand multimeter -V.A.G 1526- or multimeter
-V.A.G 1715-
- ◆ Adapter set -V.A.G 1594-
- ◆ Test box -V.A.G 1598/42- with adapter cable
-V.A.G 1598/39-1-
- ◆ Current flow diagram

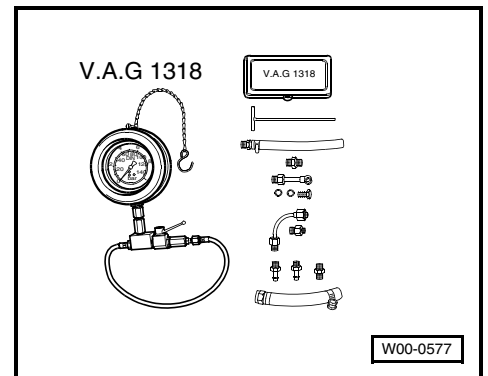

i Note

Other diagnosis testers can be used instead of the vehicle diagnosis, testing and information system.

Test prerequisites

- Fuses must be OK.
- Coolant temperature at least 80 °C
- The battery voltage must be at least 11.5 V.
- All electrical consumers must be switched off.
- Earth connection OK.

Test procedure

- Connect vehicle diagnosis, testing and information system -VAS 5051- and select diagnosis function "011-Read data block". the engine must be idling when doing so. (Connect vehicle diagnosis, testing and information system and select engine control unit ⇒ [page 3](#)).
- Select "Display group 7".

Indicated on display:

i Note

On the display of the vehicle diagnosis, testing and information system -VAS 5051- the display zones are displayed below one another and, next to one another on other diagnosis testers.

- Note display zone 4. The coolant temperature must be at least 80 °C for the subsequent test.
- Then check rail pressure as follows:
- Select "Display group 20".

Display group 7			
xxx.x °C	xxx.x °C	xxx.x °C	87.3 °C



Indicated on display:

Display group 20
880 rpm xxxx bar xxxx bar xxx.x %

i Note

On the display of the vehicle diagnosis, testing and information system -VAS 5051- the display zones are displayed below one another and, next to one another on other diagnosis testers.

- Check display zones 2 and 3 for rail pressure. In addition, observe duty cycle in display zone 4.

The rail pressure in display zone 2 should be approximately the same as rail pressure in display zone 3, but, not always the same. The pressure difference in display zones 2 and 3 must never be more than 40 bar.

- Display zone 2: Specified high-pressure (fuel): 170... 350 bar.
- Display zone 3: Actual high-pressure (fuel): 170... 350 bar.
- Display zone 4: Duty cycle (specified): 15...30 %

If the figures in display zones 2 and 3 are OK. and the pressure differential is not greater than 40 bar:

No fault is evident.

- Check return flow rate from fuel pressure regulating valve -N276- ⇒ [page 220](#).
- Then read fault memory of engine control unit and clear fault memory if necessary ⇒ [page 7](#), Clearing fault memory.

If a substitute value of 360 bar is displayed in display zones 2 + 3:

- Check fuel pressure sender -G247- ⇒ [page 235](#).

If the specification in display zone 3 is not attained or exceeded:

- Renew fuel pressure regulating valve -N276-.

If the pressure differential in display zones 2 + 3 is greater than 40 bar or specified duty cycle in display zone 4 is not attained:

- Switch off ignition.

Checking resistance

Pull connector -5- off fuel pressure regulating valve -N276-.

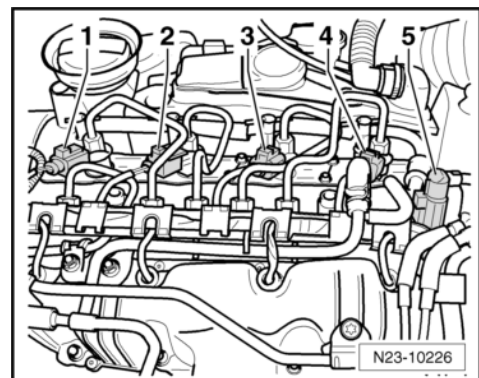



- Connect multimeter to measure resistance at connector contacts 1 + 2 of sender using auxiliary cables from -V.A.G 1594-. Specification: 3,0...6,0 Ω.

If the specification is not attained:

- Renew fuel pressure regulating valve -N276-.
- Then read fault memory of engine control unit and clear fault memory if necessary ⇒ [page 7](#), Clearing fault memory.

If specification is attained:

Checking voltage supply

- Check voltage supply of fuel pressure regulating valve -N276- as follows:
- Connect multimeter to measure voltage at connector contact 2 and engine earth using auxiliary cables from -V.A.G 1594-.
- Switch on ignition. Specification: At least 11.5 V.
- Switch off ignition.

If the specification is not attained:

- Check cable connections for open circuit, short circuit and transfer resistance at contacts according to current flow diagram.

If specification is attained:

Checking wiring

- Check fuel pressure regulating valve -N276- wiring as follows:
- Connect test box -V.A.G 1598/42- to control unit wiring harness ⇒ [page 5](#) using adapter cable -V.A.G 1598/39-1-. The engine control unit is not connected by this action.
- Check wiring between test box and connector for open circuit referring to current flow diagram.
- ◆ Contact 1 + socket 45
- Wire resistance: max. 2.0 Ω
- Also check wiring for short to one another, to battery earth/engine earth and to battery positive. Specification: ∞ Ω.

If no wiring fault is detected and voltage supply is OK:

- Renew fuel pressure regulating valve -N276-.
- Then read fault memory of engine control unit and clear fault memory if necessary ⇒ [page 7](#), Clearing fault memory.

2.3 Checking fuel pressure sender -G247-

Special tools and workshop equipment required

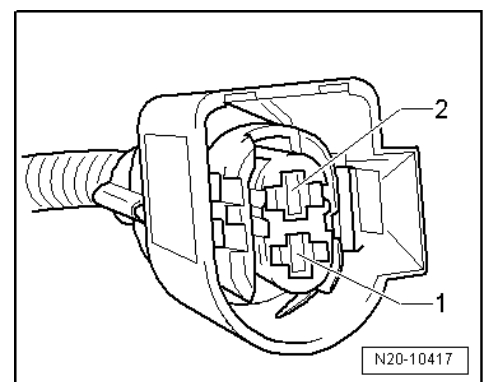
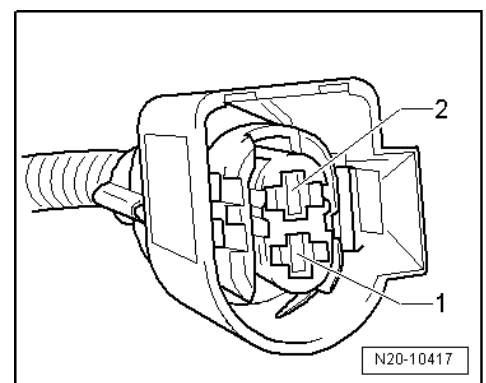
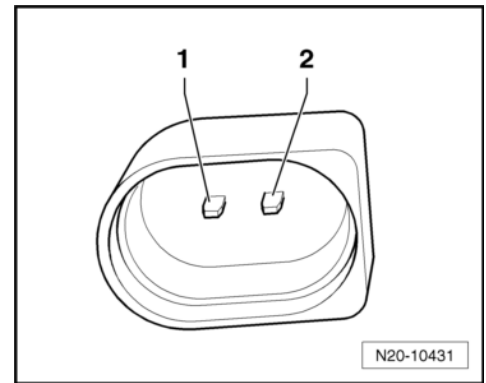



- ◆ Vehicle diagnosis, testing and information system
-VAS 5051- with diagnosis cable -VAS 5051/6A-

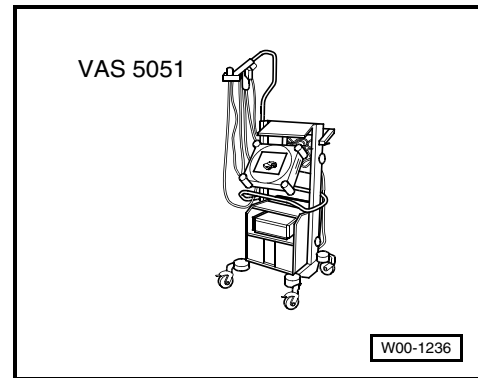

- ◆ K-Jetronic pressure tester -V.A.G 1318-
- ◆ Hand multimeter -V.A.G 1526- or multimeter
-V.A.G 1715-
- ◆ Adapter set -V.A.G 1594-
- ◆ Test box -V.A.G 1598/42- with adapter cable
-V.A.G 1598/39-1-
- ◆ Current flow diagram

i Note

Other diagnosis testers can be used instead of the vehicle diagnosis, testing and information system.

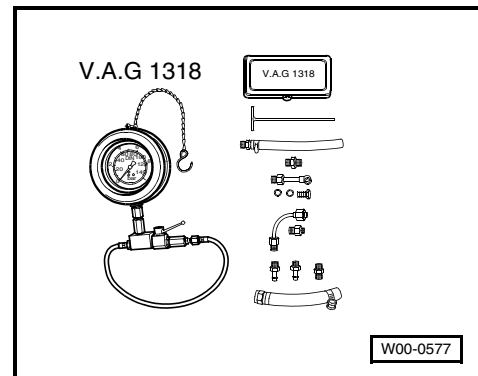

Test prerequisites

- Fuses must be OK.
- Coolant temperature at least 80 °C
- The battery voltage must be at least 11.5 V.
- All electrical consumers must be switched off.
- Earth connection OK.

Test procedure

- Note safety precautions before beginning work
⇒ [page 172](#).
- Observe rules for cleanliness ⇒ [page 173](#).
- Start engine.

If engine does start:

- Check fuel pressure while turning engine over
⇒ [page 237](#).

Engine starts:

- Connect vehicle diagnosis, testing and information system -VAS 5051- and select diagnosis function "011-Read data block". the engine must be idling when doing so. (Connect vehicle diagnosis, testing and information system and select engine control unit ⇒ [page 3](#)).
- Select "Display group 7".

Indicated on display:

Display group 7			
xxx.x °C	xxx.x °C	xxx.x °C	87.3 °C



 **Note**

On the display of the vehicle diagnosis, testing and information system -VAS 5051- the display zones are displayed below one another and, next to one another on other diagnosis testers.

- Note display zone 4. The coolant temperature must be at least 80 °C for the subsequent test.
- Then check rail pressure as follows:
- Select “Display group 20”.

Indicated on display:

Display group 20
880 rpm xxxx bar xxxx bar xxx.x %

 **Note**

On the display of the vehicle diagnosis, testing and information system -VAS 5051- the display zones are displayed below one another and, next to one another on other diagnosis testers.

- Carry out several bursts of the throttle and note display zones 2 and 3 for rail pressure at idling speed. In addition, observe duty cycle in display zone 4.

The rail pressure in display zone 2 should be approximately the same as rail pressure in display zone 3, but, not always the same. The pressure difference in display zones 2 and 3 must never be more than 40 bar.

Display zone 2: Specified high-pressure (fuel): 170... 350 bar.

Display zone 3: Actual high-pressure (fuel): 170... 350 bar.

Display zone 4: Duty cycle (specified): 15...30 %

If the figures in display zones 2 and 3 are OK. and the pressure differential is not greater than 40 bar:

No fault is evident.

- Then read fault memory of engine control unit and clear fault memory if necessary ⇒ [page 7](#), Clearing fault memory.

If the figures in display zones 2 and 3 are always identical or the pressure differential was greater than 40 bar:

- Check line connections ⇒ [page 240](#).

Checking fuel pressure while engine is turned over by starter

 **WARNING!**

- ♦ **Wrap a clean cloth around the connection before opening the fuel system. Then release pressure by carefully pulling hose off connection.**



- Pull fuel supply line -arrow- off high-pressure pump.

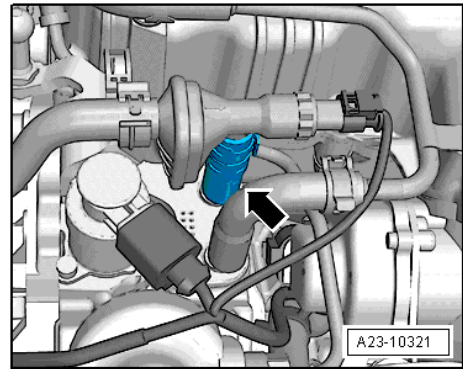

- Connect K-Jetronic pressure tester -V.A.G 1318- with suitable adapter -2- to fuel supply line -1-. Connect other adapter -3- from K-Jetronic pressure tester -V.A.G 1318- to open connection on high-pressure pump.

i Note

- ♦ The K-Jetronic pressure tester -V.A.G 1318- must be inserted as an intermediate element into the fuel supply line.
- ♦ The shut-off tap is located in direction of flow after the pressure gauge.

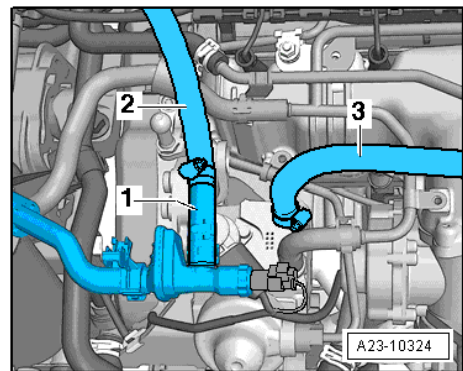

! WARNING!

- ♦ The shut-off tap of the pressure gauge must be open.
- ♦ Check that the line connections are seated correctly and securely as high pressures may occur.

- Start engine and observe pressure gauge during start procedure.

A pressure of approx. 3.5 bar must build up.

If specification is not attained:

- Check fuel pressure while starting engine ⇒ [page 239](#).

If specification is attained:

The fuel supply to the high-pressure fuel pump is OK.

- Check rail pressure union while starting engine.
- Connect vehicle diagnosis, testing and information system -VAS 5051- and select diagnosis function "011-Read data block". The ignition must be switched on. (Connect vehicle diagnosis, testing and information system and select engine control unit ⇒ [page 3](#)).
- Select "Display group 20".

Indicated on display:

i Note

On the display of the vehicle diagnosis, testing and information system -VAS 5051- the display zones are displayed below one another and, next to one another on other diagnosis testers.

Display group 20
880 rpm xxxx bar xxxx bar xxx.x %



- Have a second person start the engine, note values in display zones 2 and 3 while engine is turned over.

The rail pressure in display zone 2 should be approximately the same as rail pressure in display zone 3, but, not always the same. The pressure difference in display zones 2 and 3 must never be more than 40 bar.

If the figures in display zones 2 and 3 are OK. and the pressure differential is not greater than 40 bar:

No fault is evident.

- Check fuel system for leaks ⇒ [page 227](#).

If no fault is evident:

- Renew fuel pressure sender -G247-.
- Then read fault memory of engine control unit and clear fault memory if necessary ⇒ [page 7](#), Clearing fault memory.

If the figures in display zones 2 and 3 are always identical or the pressure differential was greater than 40 bar:

- Check line connections ⇒ [page 240](#).

Checking fuel pressure while starting engine

- Have a second person start the engine, observe pressure gauge while engine is turned over.
- Then slowly and carefully close shut-off tap until pressure tester indicates a pressure of max. 8 bar.
- Switch off ignition.

If specification is attained:

The fuel supply to the high-pressure fuel pump is OK.

- Renew fuel pressure sender -G247-.
- Then read fault memory of engine control unit and clear fault memory if necessary ⇒ [page 7](#), Clearing fault memory.

If the fault occurs again:

- Renew fuel pressure regulating valve -N276-.
- Then read fault memory of engine control unit and clear fault memory if necessary ⇒ [page 7](#), Clearing fault memory.

If the fault occurs again:

- Renew fuel metering valve -N290-.
- Then read fault memory of engine control unit and clear fault memory if necessary ⇒ [page 7](#), Clearing fault memory.

If the fault occurs again:

- Renew high-pressure pump.



If specification is not attained:

- Check fuel lines e.g for kinked lines and blocked fuel filter.
- Check fuel pump ⇒ [page 179](#).

If no fault is evident:

- Test fuel pump relay -J49- ⇒ [page 305](#).

Checking voltage supply

- Connect multimeter using auxiliary cables from -V.A.G 1594- to measure voltage at connector contacts 1 + 3.
- Switch on ignition. Specification: At least 4.8 V...5.2 V.
- Switch off ignition.

Checking wiring

- Connect test box -V.A.G 1598/42- to control unit wiring harness ⇒ [page 5](#) using adapter cable -V.A.G 1598/39-1-. The engine control unit is not connected by this action.
- Check wiring between test box and connector for open circuit referring to current flow diagram.
 - ◆ Contact 1 + socket 53
 - ◆ Contact 1 + socket 40
 - ◆ Contact 3 + socket 25
- Wire resistance: max. 2.0 Ω
- Also check wiring for short to one another, to battery earth/engine earth and to battery positive. Specification: ∞ Ω.

If no wiring fault is detected and voltage was present between contacts 1 + 3:

- Renew fuel pressure sender -G247-.
- Then read fault memory of engine control unit and clear fault memory if necessary ⇒ [page 7](#), Clearing fault memory.

If no wiring fault is detected and no voltage was present between contacts 1 + 3:

- Pull connectors off all components which are connected to this voltage supply line ⇒ [page 305](#), Current flow diagram.
- Check voltage supply and wiring for all these components.

If no wiring fault is detected and no voltage was present at these components:

- Renew engine control unit -J623- ⇒ [page 259](#).
- Then read fault memory of engine control unit and clear fault memory if necessary ⇒ [page 7](#), Clearing fault memory.

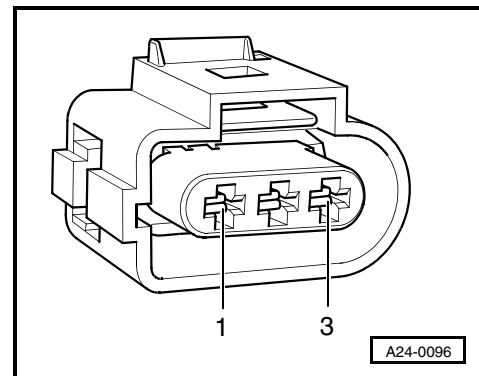
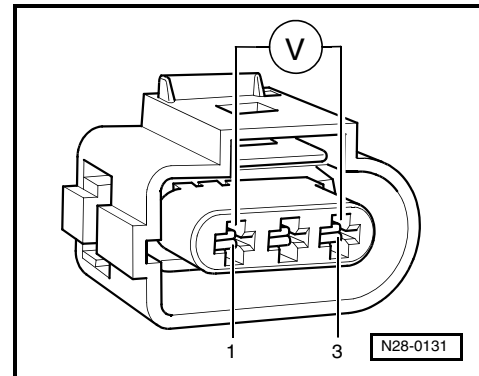



2.4 Checking Injectors (cylinders 1...4) -N30...N33-

Special tools and workshop equipment required

- ◆ Hand multimeter -V.A.G 1526- or multimeter -V.A.G 1715-
- ◆ Adapter set -V.A.G 1594-
- ◆ Test box -V.A.G 1598/42- with adapter cable -V.A.G 1598/39-1-
- ◆ Current flow diagram

Test prerequisites

- Fuses must be OK.
- The battery voltage must be at least 11.5 V.
- All electrical consumers must be switched off.
- Earth connection OK.

Test procedure

- Switch off ignition.

Checking resistance

Pull connector -1...4- off injector to be tested.

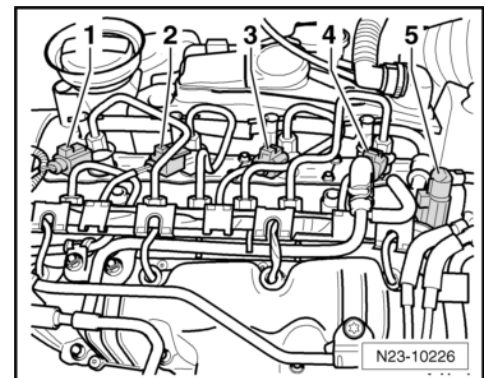

- Connect multimeter to measure resistance at connector contacts 1 + 2 of valve using auxiliary cables from -V.A.G 1594-. Specification: 50.0...700.0 k Ω

If the specification is not attained:

- Renew respective injector.
- Then read fault memory of engine control unit and clear fault memory if necessary ⇒ [page 7](#), Clearing fault memory.

If specification is attained:

Checking for short to earth

- Connect multimeter to respective injector using auxiliary cables from -V.A.G 1594-, as follows:
 - ◆ Injector contact 1 + engine earth
 - ◆ Injector contact 2 + engine earth

Specification: > 9 M Ω

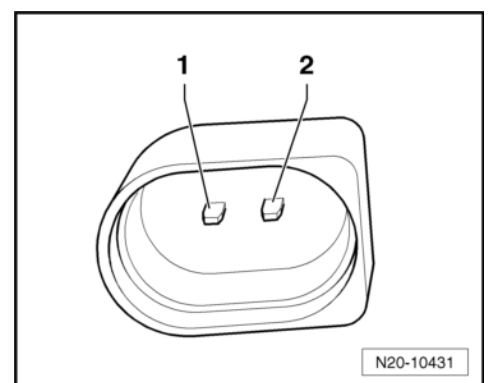



If the specification is not attained:

- Renew respective injector.
- Then read fault memory of engine control unit and clear fault memory if necessary ⇒ [page 7](#), Clearing fault memory.

If specification is attained:

Checking wiring

- Check injector wiring as follows:
- Connect test box -V.A.G 1598/42- to control unit wiring harness ⇒ [page 5](#) using adapter cable -V.A.G 1598/39-1-. The engine control unit is not connected by this action.
- Check wiring between test box and connector for open circuit referring to current flow diagram.
- ◆ Injector 1 N30: Contact 1 + socket 2
- ◆ Injector 1 N30: Contact 2 + socket 17
- ◆ Injector 2 N31: Contact 1 + socket 47
- ◆ Injector 2 N31: Contact 2 + socket 32
- ◆ Injector 3 N32: Contact 1 + socket 46
- ◆ Injector 3 N32: Contact 2 + socket 31
- ◆ Injector 4 N33: Contact 1 + socket 1
- ◆ Injector 4 N33: Contact 2 + socket 16
- Wire resistance: max. 2.0 Ω
- Additionally check the wiring for:
 - ◆ Short to positive Specification: -0.5...0.5
 - ◆ Short to earth Specification: > 9 MΩ
 - ◆ Short circuit to one another. Specification: ∞ Ω.

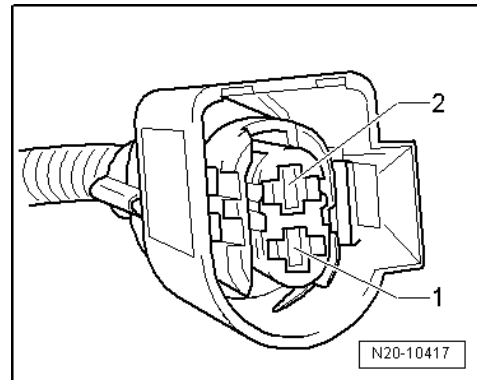

If no fault in lines is detected:

- Renew respective injector ⇒ [page 259](#).
- Write “injector delivery calibration values” and values for new injector to engine control unit ⇒ [page 261](#).
- Then read fault memory of engine control unit and clear fault memory if necessary ⇒ [page 7](#), Clearing fault memory.

2.5 Checking engine speed sender -G28-

Operation

Engine speed sender -G28- is speed and reference mark sender. The engine will not start if there is no speed signal. If the speed signal fails when the engine is running, it will cause the engine to stall immediately.

Special tools and workshop equipment required



- ◆ Hand multimeter -V.A.G 1526- or multimeter -V.A.G 1715-
- ◆ Adapter set -V.A.G 1594-
- ◆ Test box -V.A.G 1598/42- with adapter cable -V.A.G 1598/39-1-
- ◆ Current flow diagram

Test prerequisites

- Fuses must be OK.
- The battery voltage must be at least 11.5 V.
- All electrical consumers must be switched off.
- Earth connection OK.

Test procedure



Note

Only gold-plated contacts may be used when repairing the engine speed sender connector contacts.

- Clamp off coolant hoses at oil cooler using hose clamp and pull off hoses.
- Remove oil filter bracket ⇒ [page 152](#), Assembly overview - oil filter bracket and oil cooler
- Pull 3-pin connector off engine speed sender -G28-.

Checking resistance

- Connect multimeter to measure resistance at connector contacts 1 + 2 of sender using auxiliary cables from -V.A.G 1594-. Specification: 450.0...650.0 Ω .
- Additionally check wires for short to screening.
- ◆ Contact 1 + 3
- ◆ Contact 2 + 3
- Specification: $\infty \Omega$

If the specifications are not attained

- Renew engine speed sender -G28- ⇒ [page 97](#).
- Then read fault memory of engine control unit and clear fault memory if necessary ⇒ [page 7](#), Clearing fault memory.

If the specifications are attained:

Checking voltage supply

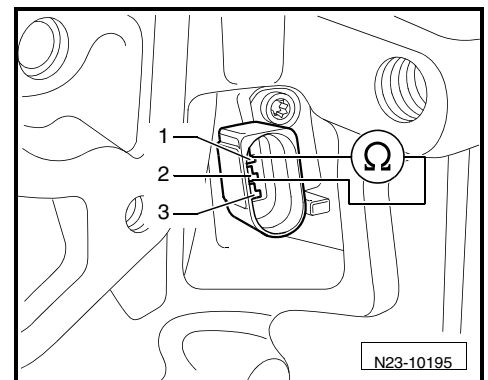



- Connect multimeter using auxiliary cables from -V.A.G 1594- to measure voltage at connector contacts 1 + 3.
- Switch on ignition. Specification: At least 4.8... 5.2 V.
- Switch off ignition.
- Check engine speed sender wiring as follows:
- Connect test box -V.A.G 1598/42- to control unit wiring harness ⇒ [page 5](#) using adapter cable -V.A.G 1598/39-1-. The engine control unit is not connected by this action.

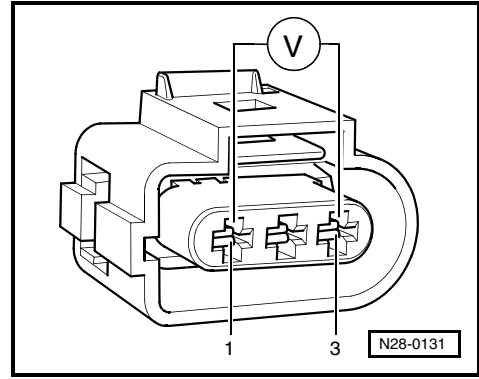

- Check wiring between test box and connector for open circuit referring to current flow diagram.
- ◆ Contact 1 + socket 25
- ◆ Contact 2 + socket 52
- ◆ Contact 3 + socket 53
- Wire resistance: max. 2.0 Ω
- Also check wiring for short to one another, to battery earth/engine earth and to battery positive. Specification: ∞ Ω.

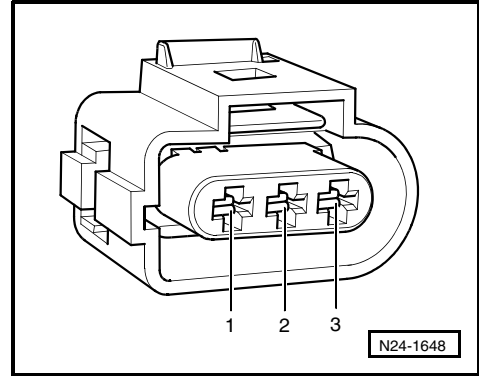

If no fault in lines is detected:

- Remove engine speed sender -G28- ⇒ [page 97](#).
- Check sender wheel for:
 - ◆ Secure seating.
 - ◆ Damage.
 - ◆ True running.
 - ◆ Metal particles on sender wheel or sender.

If no fault is found on sender wheel or wiring and voltage was present between contacts 1 + 3:

- Renew engine speed sender -G28-.
- Then read fault memory of engine control unit and clear fault memory if necessary ⇒ [page 7](#), Clearing fault memory.

If no fault is found on sender wheel or wiring and no voltage was present between contacts 1 + 3:

- Pull connectors off all components which are connected to this voltage supply line ⇒ [page 305](#), Current flow diagram.
- Check voltage supply and wiring for all these components.

If no wiring fault is detected and no voltage was present at these components:

- Renew engine control unit -J623- ⇒ [page 259](#).



2.6 Checking Hall sender -G40-

Special tools and workshop equipment required

- ◆ Hand multimeter -V.A.G 1526- or multimeter -V.A.G 1715-
- ◆ Adapter set -V.A.G 1594-
- ◆ Test box -V.A.G 1598/42- with adapter cable -V.A.G 1598/39-1-
- ◆ Current flow diagram

Test prerequisites

- Fuses must be OK.
- The battery voltage must be at least 11.5 V.
- All electrical consumers must be switched off.
- Earth connection OK.

Test procedure

- Disconnect 3-pin connector -1- at Hall sender -G40-.

Checking voltage supply

- Connect multimeter using auxiliary cables from -V.A.G 1594- to measure voltage at connector contacts 1 + 3.
- Switch on ignition. Specification: At least 4.8... 5.2 V.
- Switch off ignition.
- Check Hall sender wiring as follows:
- Connect test box -V.A.G 1598/42- to control unit wiring harness ⇒ [page 5](#) using adapter cable -V.A.G 1598/39-1-. The engine control unit is not connected by this action.

- Check wiring between test box and connector for open circuit referring to current flow diagram.

- ◆ Contact 1 + socket 10
- ◆ Contact 2 + socket 44
- ◆ Contact 3 + socket 51
- Wire resistance: max. 2.0 Ω

- Also check wiring for short to one another, to battery earth/engine earth and to battery positive. Specification: ∞ Ω.

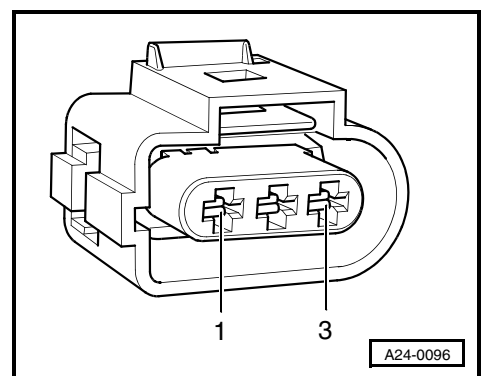
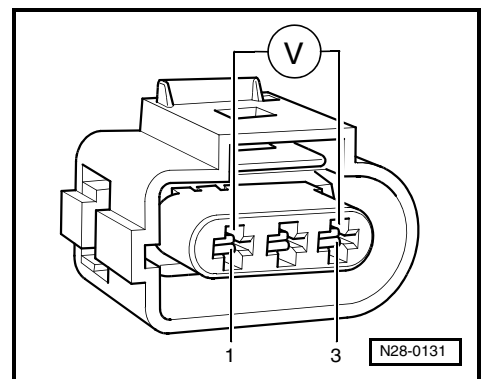
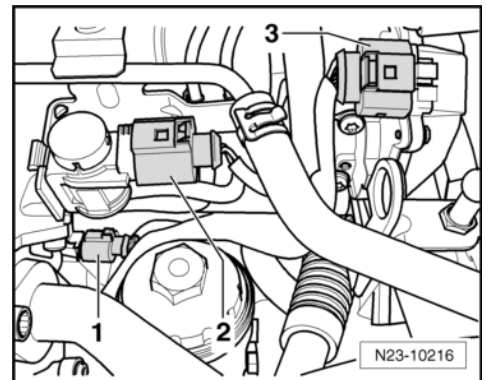



If no wiring fault is detected and voltage was present between contacts 1 + 3:

- Renew Hall sender -G40- ⇒ [page 109](#), Assembly overview - cylinder head.
- Then read fault memory of engine control unit and clear fault memory if necessary ⇒ [page 7](#), Clearing fault memory.

If no wiring fault is detected and no voltage was present between contacts 1 + 3:

- Pull connectors off all components which are connected to this voltage supply line ⇒ [page 305](#), Current flow diagram.
- Check voltage supply and wiring for all these components.

If no wiring fault is detected and no voltage was present at these components:

- Renew engine control unit -J623- ⇒ [page 259](#).

2.7 Checking intake air temperature sender -G42-

Special tools and workshop equipment required

- ♦ Vehicle diagnosis, testing and information system -VAS 5051- with diagnosis cable -VAS 5051/6A-
- ♦ Hand multimeter -V.A.G 1526- or multimeter -V.A.G 1715-
- ♦ Adapter set -V.A.G 1594-
- ♦ Test box -V.A.G 1598/42- with adapter cable -V.A.G 1598/39-2-
- ♦ Current flow diagram



Note

Other diagnosis testers can be used instead of the vehicle diagnosis, testing and information system.

Test prerequisites

- Fuses must be OK.
- The battery voltage must be at least 11.5 V.
- All electrical consumers must be switched off.
- Earth connection OK.

Test procedure



Note

- ♦ *The intake air temperature sender -G42- and the charge air pressure sender -G31- are installed together in a housing in the charge air pipe.*
- ♦ *Only gold-plated contacts may be used when repairing the connector contacts.*

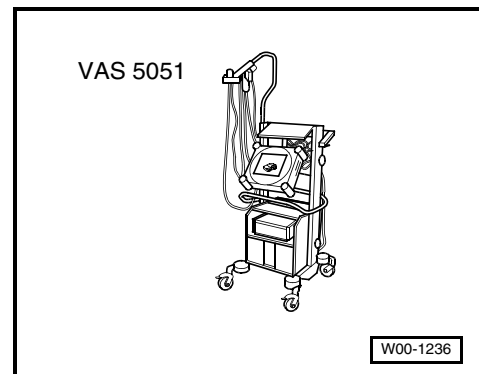



- Connect vehicle diagnosis, testing and information system -VAS 5051- and select diagnosis function "011-Read data block". the engine must be idling when doing so. (Connect vehicle diagnosis, testing and information system and select engine control unit ⇒ page 3).
- Select "Display group 7".

Indicated on display:

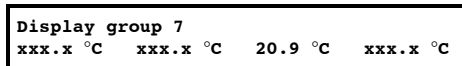

i Note

On the display of the vehicle diagnosis, testing and information system -VAS 5051- the display zones are displayed below one another and, next to one another on other diagnosis testers.

- Check intake manifold temperature value in display zone 3. The temperature value must be approx. ambient temperature.
- If no realistic display appears in display zone 3 check intake manifold temperature sender and wiring to sender as follows:
- Terminate diagnosis function.
- Switch off ignition.

Checking resistance

- Pull 4-pin connector off intake air temperature sender -5-.

i Note

The intake air temperature sender -G42- and the charge air pressure sender -G31- are installed together in a housing in the charge air pipe.

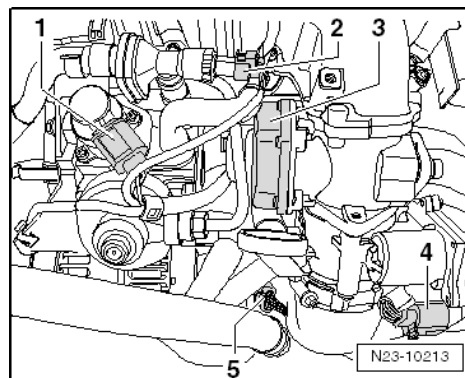

- Connect multimeter to measure resistance at connector contacts 1 + 2 of sender using auxiliary cables from -V.A.G 1594-.

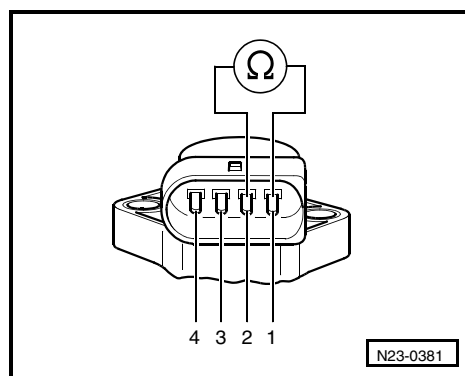



Scale -A- shows resistance values for temperature range 0...50 °C and scale -B- the values for temperature range 50...100 °C.

Specimen readings:

- ◆ 30 °C is in range -A- and corresponds to a resistance of 1500...2000 Ω.
- ◆ 80 °C is in range -B- and corresponds to a resistance of 275...375 Ω.

If the specification is not attained:

- Renew intake air temperature sender -G42- with charge air pressure sender -G31-.
- Then read fault memory of engine control unit and clear fault memory if necessary ⇒ [page 7](#), Clearing fault memory.

If specification is attained:

Checking voltage supply

- Connect multimeter using auxiliary cables from -V.A.G 1594- to measure voltage at connector contacts 1 + 3.
- Switch on ignition. Specification: At least 4.8... 5.2 V.
- Switch off ignition.
- Check intake air temperature sender wiring as follows:
- Connect test box -V.A.G 1598/42- to control unit wiring harness ⇒ [page 5](#) using adapter cable -V.A.G 1598/39-2-. The engine control unit is not connected by this action.
- Check wiring between test box and connector for open circuit referring to current flow diagram.
- ◆ Contact 1 + socket 66
- ◆ Contact 2 + socket 30
- Wire resistance: max. 2.0 Ω
- Also check wiring for short to one another, to battery earth/engine earth and to battery positive. Specification: ∞ Ω.

If no wiring fault is detected and voltage was present between contacts 1 + 3:

- Renew intake air temperature sender -G42- with charge air pressure sender -G31-.

If no wiring fault is detected and no voltage was present between contacts 1 + 3:

- Pull connectors off all components which are connected to this voltage supply line ⇒ [page 305](#), Current flow diagram.
- Check voltage supply and wiring for all these components.

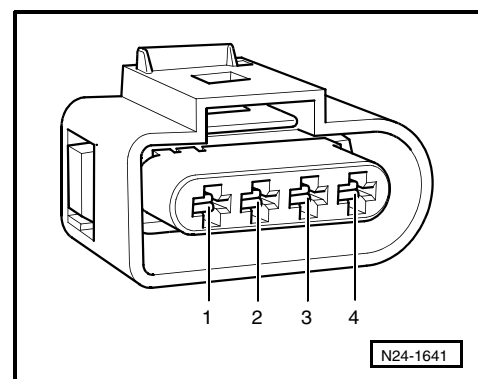
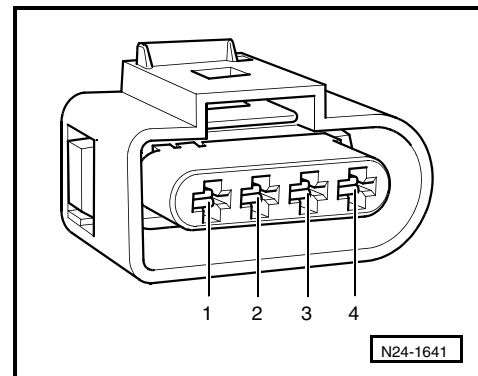
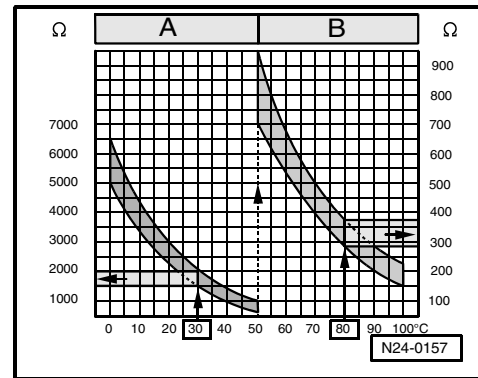



If no wiring fault is detected and no voltage was present at these components:

- Renew engine control unit -J623- ⇒ [page 259](#).

2.8 Checking coolant temperature sender -G62-

Special tools and workshop equipment required

- ◆ Vehicle diagnosis, testing and information system -VAS 5051- with diagnosis cable -VAS 5051/6A-
- ◆ Hand multimeter -V.A.G 1526- or multimeter -V.A.G 1715-
- ◆ Adapter set -V.A.G 1594-
- ◆ Test box -V.A.G 1598/42- with adapter cable -V.A.G 1598/39-1-
- ◆ Current flow diagram



Note

Other diagnosis testers can be used instead of the vehicle diagnosis, testing and information system.

Test prerequisites

- Fuses must be OK.
- The battery voltage must be at least 11.5 V.
- All electrical consumers must be switched off.
- Earth connection OK.
- Engine must be cold.

Test procedure



Note

Only gold-plated contacts may be used when repairing the coolant temperature sender connector contacts.

- Connect vehicle diagnosis, testing and information system -VAS 5051- and select diagnosis function "011-Read data block". the engine must be idling when doing so. (Connect vehicle diagnosis, testing and information system and select engine control unit ⇒ [page 3](#)).
- Select "Display group 7".

Indicated on display:



Note

On the display of the vehicle diagnosis, testing and information system -VAS 5051- the display zones are displayed below one another and, next to one another on other diagnosis testers.

- Check coolant temperature value in display zone 4. The temperature value must increase uniformly and without interruption.

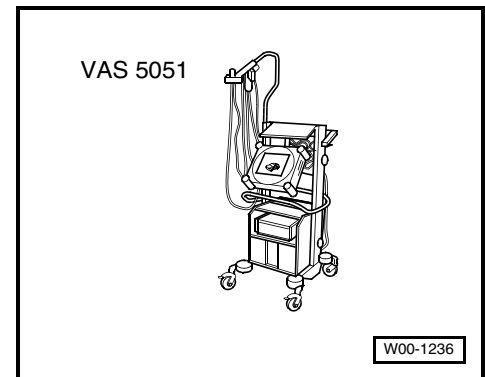

Display group 7			
xxx.x °C	xxx.x °C	xxx.x °C	16.7 °C



i Note

If there is a fault, the fuel temperature (display zone 1) will be shown as a substitute value.

- If no realistic display appears in display zone 4 or the fuel temperature is displayed as a substitute. Check coolant temperature sender and wiring connections to sender as follows:
- Terminate diagnosis function.
- Switch off ignition.

Checking resistance

- Pull 2-pin connector -arrow- off coolant temperature sender -G62-.

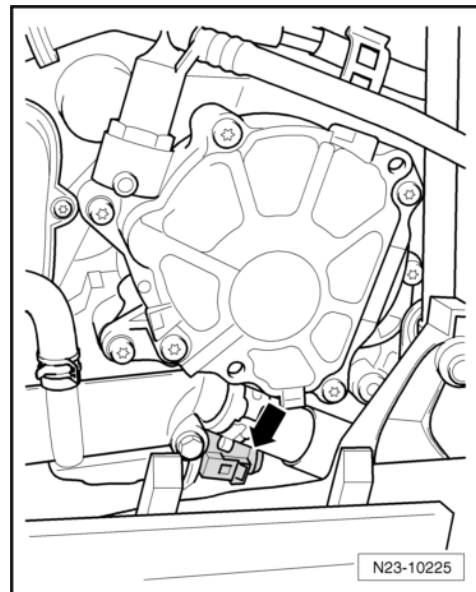

- Connect multimeter to measure resistance at contacts of sender using auxiliary cables from -V.A.G 1594-.

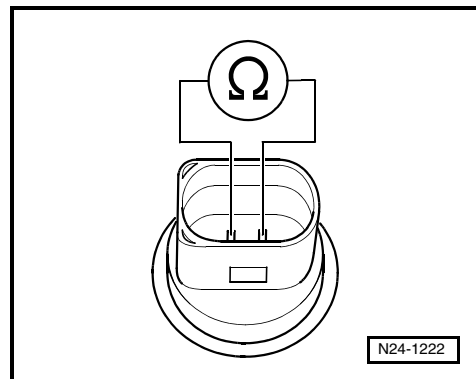

Scale -A- shows resistance values for temperature range 0...50 °C and scale -B- the values for temperature range 50...100 °C.

Specimen readings:

- ◆ 30 °C is in range -A- and corresponds to a resistance of 1500...2000 Ω.
- ◆ 80 °C is in range -B- and corresponds to a resistance of 275...375 Ω.

If the specification is not attained:

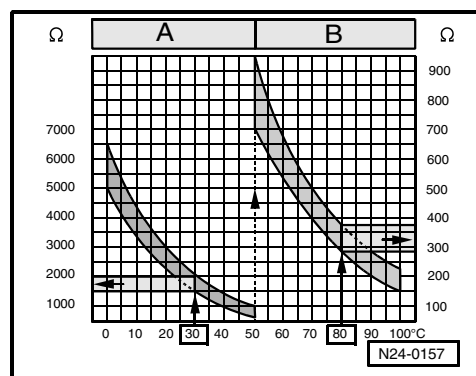



- Renew coolant temperature sender -G62- ⇒ [page 156](#), Parts of cooling system - engine side.
- Then read fault memory of engine control unit and clear fault memory if necessary ⇒ [page 7](#), Clearing fault memory.

If specification is attained:

- Check coolant temperature sender wiring as follows:
- Connect test box -V.A.G 1598/42- to control unit wiring harness ⇒ [page 5](#) using adapter cable -V.A.G 1598/39-1-. The engine control unit is not connected by this action.
- Check wiring between test box and connector for open circuit referring to current flow diagram.
- ◆ Contact 1 + socket 53
- ◆ Contact 2 + socket 54
- Wire resistance: max. 2.0 Ω
- Also check wiring for short to one another, to battery earth/engine earth and to battery positive. Specification: ∞ Ω.

If no fault in lines is detected:

- Renew engine control unit -J623- ⇒ [page 259](#).

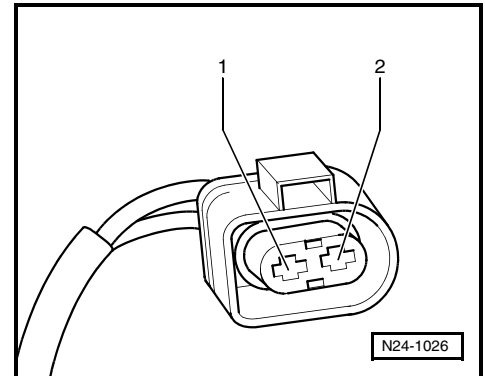

2.9 Checking fuel temperature sender -G81-

Special tools and workshop equipment required

- ◆ Vehicle diagnosis, testing and information system -VAS 5051- with diagnosis cable -VAS 5051/6A-
- ◆ Hand multimeter -V.A.G 1526- or multimeter -V.A.G 1715-
- ◆ Adapter set -V.A.G 1594-
- ◆ Test box -V.A.G 1598/42- with adapter cable -V.A.G 1598/39-1-
- ◆ Current flow diagram



Note

Other diagnosis testers can be used instead of the vehicle diagnosis, testing and information system.

Test prerequisites

- Fuses must be OK.
- The battery voltage must be at least 11.5 V.
- All electrical consumers must be switched off.
- Earth connection OK.
- No air in fuel system.

Test procedure

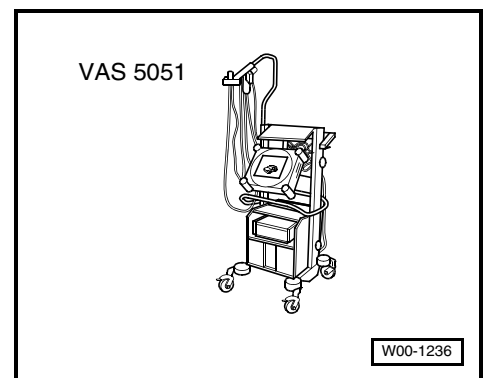



i Note

Only gold-plated contacts may be used when repairing the fuel temperature sender connector contacts.

- Connect vehicle diagnosis, testing and information system -VAS 5051- and select diagnosis function "011-Read data block". the engine must be idling when doing so. (Connect vehicle diagnosis, testing and information system and select engine control unit ⇒ [page 3](#)).
- Select "Display group 7".

Indicated on display:

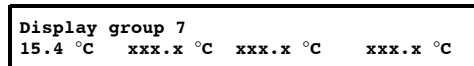

i Note

On the display of the vehicle diagnosis, testing and information system -VAS 5051- the display zones are displayed below one another and, next to one another on other diagnosis testers.

- Check fuel temperature value in display zone 1. The temperature value must be approx. ambient temperature.
- If no realistic display appears in display zone 1 check fuel temperature sender and wiring to sender as follows:
- Terminate diagnosis function.
- Switch off ignition.

Checking resistance

- Pull 2-pin connector -2- off fuel temperature sender.
- Connect multimeter to measure resistance at contacts of sender using auxiliary cables from -V.A.G 1594-.

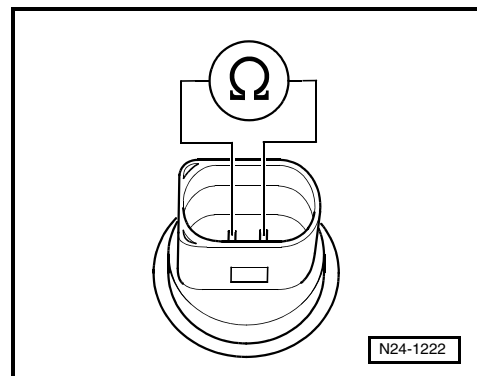
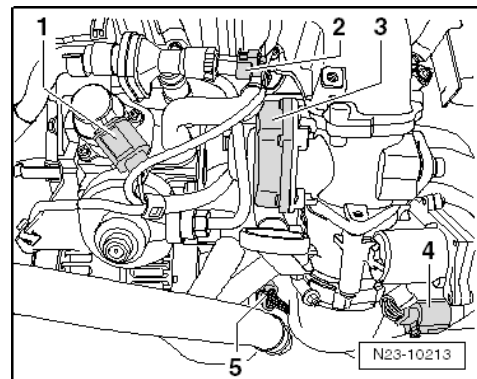



Scale -A- shows resistance values for temperature range 0...50 °C and scale -B- the values for temperature range 50...100 °C.

Specimen readings:

- ◆ 30 °C is in range -A- and corresponds to a resistance of 1500...2000 Ω.
- ◆ 80 °C is in range -B- and corresponds to a resistance of 275...375 Ω.

If the specification is not attained:

- Renew fuel temperature sender -G81-.
- Then read fault memory of engine control unit and clear fault memory if necessary ⇒ [page 7](#), Clearing fault memory.

If specification is attained:

- Check fuel temperature sender wiring as follows:
- Connect test box -V.A.G 1598/42- to control unit wiring harness ⇒ [page 5](#) using adapter cable -V.A.G 1598/39-1-. The engine control unit is not connected by this action.
- Check wiring between test box and connector for open circuit referring to current flow diagram.
- ◆ Contact 1 + socket 53
- ◆ Contact 2 + socket 42
- Wire resistance: max. 2.0 Ω
- Also check wiring for short to one another, to battery earth/engine earth and to battery positive. Specification: ∞ Ω.

If no fault in lines is detected:

- Renew engine control unit -J623- ⇒ [page 259](#).

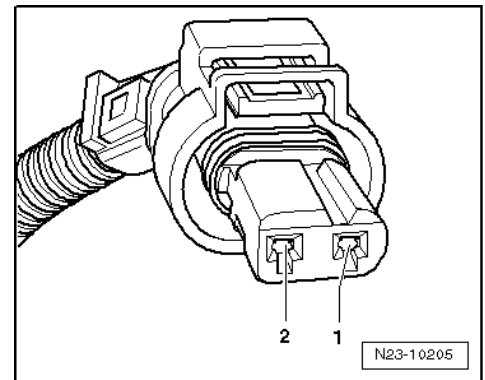
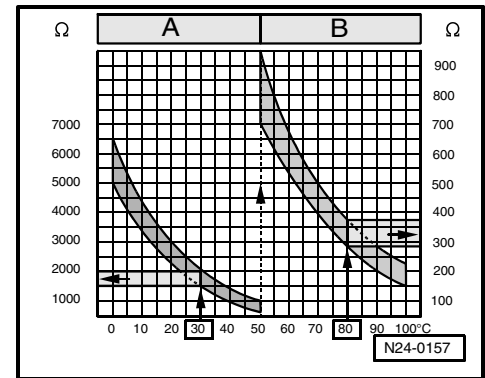

2.10 Checking air mass meter -G70-

Operation

The air mass meter signal is required by the engine control unit for calculating the permissible injection quantity and for controlling exhaust gas recirculation. The smaller the signal from air mass meter the smaller the quantity of fuel injected.

Special tools and workshop equipment required

- ◆ Hand multimeter -V.A.G 1526- or multimeter -V.A.G 1715-
- ◆ Adapter set -V.A.G 1594-
- ◆ Test box -V.A.G 1598/42- with adapter cable -V.A.G 1598/39-2-
- ◆ Current flow diagram

Test prerequisites



- Fuses must be OK.
- The battery voltage must be at least 11.5 V.
- All electrical consumers must be switched off.
- Earth connection OK.
- No leaks on intake and exhaust systems.
- No faults must be stored in fault memory ⇒ [page 7](#), Reading fault memory.
- Charge pressure control OK., checking ⇒ [page 192](#).
- Exhaust gas recirculation OK., checking ⇒ [page 269](#).

Test procedure



Note

Only gold-plated contacts may be used when repairing the air mass meter connector contacts.

Checking voltage supply

- Pull 5-pin connector -6- off air mass meter -G70-.
- Switch on ignition.

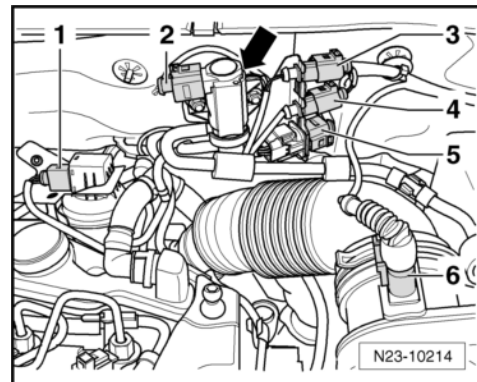

- Connect multimeter to measure voltage at following connector contacts and engine earth using auxiliary cables from -V.A.G 1594-.

- ◆ Contact 5 + engine earth
- Specification: At least 11.5 V.

- Switch off ignition.

If the specification is not attained:

- Check air mass meter wiring as follows:
- Connect test box -V.A.G 1598/42- to control unit wiring harness ⇒ [page 5](#) using adapter cable -V.A.G 1598/39-2-. The engine control unit is not connected by this action.

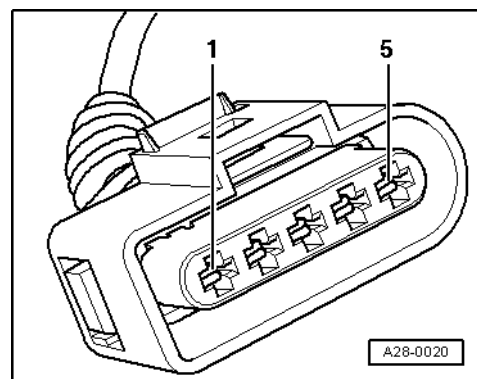



- Check wiring between test box and connector for open circuit referring to current flow diagram.
- ◆ Contact 1 + socket 18
- ◆ Contact 1 + socket 23
- ◆ Contact 4 + socket 39
- ◆ Contact 5 + socket 87
- Wire resistance: max. 2.0 Ω
- Check wiring between 5-pin connector contact 5 and fuse referring to current flow diagram ⇒ [page 305](#).
- Also check wiring for short to one another, to battery earth/engine earth and to battery positive. Specification: ∞ Ω.

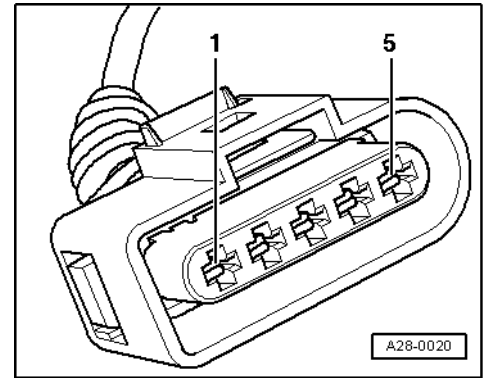

If no fault in lines is detected:

- Renew air mass meter.

2.11 Checking throttle valve module -J338-

Special tools and workshop equipment required

- ◆ Vehicle diagnosis, testing and information system -VAS 5051- with diagnosis cable -VAS 5051/6A-
- ◆ Hand multimeter -V.A.G 1526- or multimeter -V.A.G 1715-
- ◆ Adapter set -V.A.G 1594-
- ◆ Test box -V.A.G 1598/42- with adapter cable -V.A.G 1598/39-1-
- ◆ Current flow diagram



Note

Other diagnosis testers can be used instead of the vehicle diagnosis, testing and information system.

Test prerequisites

- Fuses must be OK.
- The battery voltage must be at least 11.5 V.
- All electrical consumers must be switched off.
- Earth connection OK.
- Throttle valve module not soiled.
- Engine running at idling speed

Test procedure



Note

- ◆ *The throttle valve module -J338- and throttle valve potentiometer -G69- are installed together in a housing.*
- ◆ *Only gold-plated contacts may be used when repairing the throttle valve module -J338- connector contacts.*

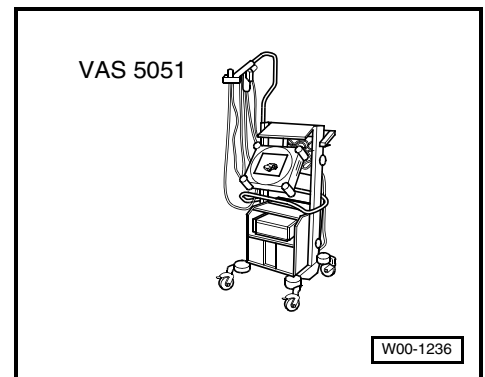



- Carry out final control diagnosis and actuate throttle valve module -J338- ⇒ [page 47](#), Final control diagnosis.
- The engine must stop when actuating the throttle valve module
- Proceed with final control diagnosis until completed.
- Terminate diagnosis function.
- Switch off ignition.

The engine does not stop when actuating the throttle valve module:

- Pull 5-pin connector -4- off throttle valve module.

Checking voltage supply

- Switch on ignition.

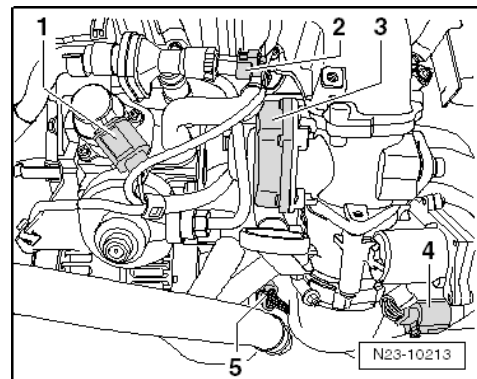

- Connect multimeter to measure voltage at following connector contacts and engine earth using auxiliary cables from -V.A.G 1594-.

- ◆ Contact 1 + engine earth
- ◆ Contact 1 + contact 3
- Specification: At least 4.8... 5.2 V

- Switch off ignition.
- Check throttle valve module -J338- wiring as follows:
- Connect test box -V.A.G 1598/42- to control unit wiring harness ⇒ [page 5](#) using adapter cable -V.A.G 1598/39-1-. The engine control unit is not connected by this action.
- Check wiring between test box and connector for open circuit referring to current flow diagram.

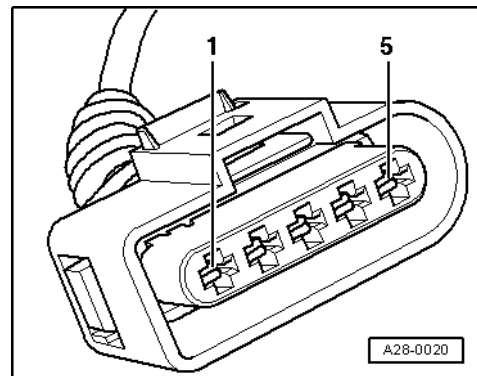

- ◆ Contact 1 + socket 25
- ◆ Contact 2 + socket 41
- ◆ Contact 3 + socket 53
- ◆ Contact 4 + socket 49
- ◆ Contact 5 + socket 34

- Wire resistance: max. 2.0 Ω
- Additionally check wires for short to one another. Specification: ∞ Ω.

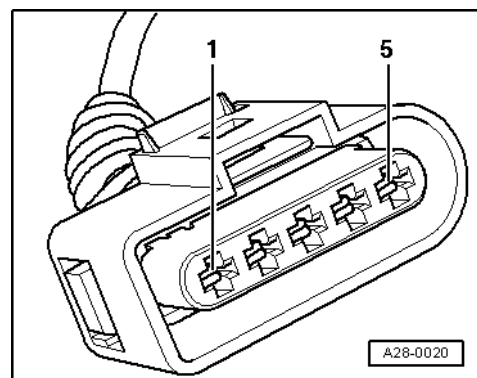

If no wiring fault is detected and voltage was present between contacts 1 + engine earth and 1 + 3:

- Renew throttle valve module -J338- ⇒ [page 209](#).



- Perform adaption of throttle valve module -J338-
⇒ [page 264](#).
- Then read fault memory of engine control unit and clear fault memory if necessary ⇒ [page 7](#), Clearing fault memory.

If no wiring fault is detected and no voltage was present between contacts 1 + engine earth and 1 + 3:

- Pull connectors off all components which are connected to this voltage supply line ⇒ [page 305](#), Current flow diagram.
- Check voltage supply and wiring for all these components.

If no wiring fault is detected and no voltage was present at these components:

- Renew engine control unit -J623- ⇒ [page 259](#).

3 Engine control unit -J623-

Checking voltage supply for engine control unit ⇒ [page 257](#).

Renewing engine control unit ⇒ [page 259](#).

Adapting exhaust gas pressure sensor 1 -G450- ⇒ [page 260](#).

Checking comparison values for amount injected (IDC/IVC) and writing to engine control unit ⇒ [page 261](#).

Adapting engine control unit -J623- to position sender for charge pressure positioner -G581- ⇒ [page 262](#).

Adapting engine control unit -J623- to exhaust gas recirculation valve ⇒ [page 263](#).

Adapting engine control unit -J623- to throttle valve module -J338- ⇒ [page 264](#).

Checking data bus ⇒ [page 264](#).

3.1 Checking voltage supply for engine control unit

Special tools and workshop equipment required

- ◆ Hand multimeter -V.A.G 1526- or multimeter -V.A.G 1715-
- ◆ Adapter set -V.A.G 1594-
- ◆ Test box -V.A.G 1598/42- with adapter cable -V.A.G 1598/39-2-
- ◆ Current flow diagram

Test prerequisites

- Fuses must be OK.
- The battery voltage must be at least 11.5 V.
- All electrical consumers must be switched off.
- Earth connection OK.



Test procedure

- Connect test box -V.A.G 1598/42- to wiring harness and control unit ⇒ [page 5](#) using adapter cable -V.A.G 1598/39-2-.
- Connect multimeter using auxiliary cables from -V.A.G 1594- to measure voltage between following sockets of test box:
 - ◆ 1 + 87
 - ◆ 2 + 87
 - ◆ 4 + 87
- Specification: Approx. 0.0 V
- Switch on ignition.
- Measure voltage again between sockets of test box:
 - ◆ 1 + 87
 - ◆ 2 + 87
 - ◆ 4 + 87
- Specification: Approx. battery voltage
- Switch off ignition.
- Connect multimeter using auxiliary cables from -V.A.G 1594- to measure voltage between following sockets of test box:
 - ◆ 1 + 92
 - ◆ 2 + 92
 - ◆ 4 + 92
- Specification: Approx. battery voltage

If the specifications are not attained

- Check terminal 30 voltage supply relay -J317- ⇒ [page 305](#), Current flow diagram.
- Check cable connections for open circuit, short circuit and transfer resistance at contacts according to current flow diagram.

If no fault is found in wiring and relay:

- Renew engine control unit -J623- ⇒ [page 259](#).



3.2 Renewing engine control unit

Special tools and workshop equipment required

- ◆ Vehicle diagnosis, testing and information system
-VAS 5051- with diagnosis cable -VAS 5051/6A-

Note

Other diagnosis testers can be used instead of the vehicle diagnosis, testing and information system.

Procedure

- First check control unit identification and thereby the current engine control unit coding as follows:
- Connect vehicle diagnosis, testing and information system -VAS 5051- and select vehicle system “01-Engine electronics”. The ignition must be switched on for this purpose. (Connect fault reader and select engine control unit -J623- ⇒ [page 3](#)).

The control unit identification and coding of the engine control unit are shown on the display.

- Read adaption value (odometer reading) of ash mass of particulate filter ⇒ [page 282](#), Checking particulate filter.
- Read comparison values for amount injected (IDC/IVC) ⇒ [page 261](#).
- Terminate diagnosis function.
- Switch off ignition.
- Release both connectors on engine control unit -J623- and pull them off.
- Remove engine control unit and install new engine control unit.
- Reconnect engine control unit connector(s) and lock connector(s).
- Code engine control unit -J623- (according to manufacture instructions).
- Write previously read adaption values (kilometre reading) of ash mass of particulate filter to new engine control unit ⇒ [page 282](#), Checking particulate filter.
- Write previously read comparison values for amount injected (IDC/IVC) to engine control unit.
- Then read fault memory of engine control unit and clear fault memory if necessary ⇒ [page 7](#), Clearing fault memory.

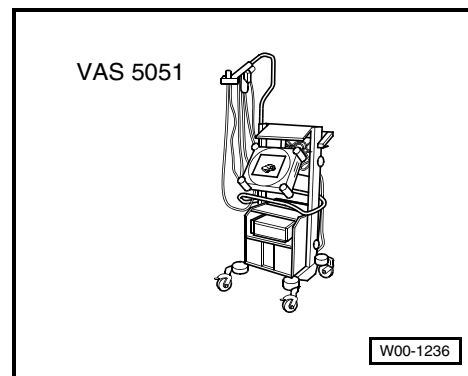



3.3 Adapting exhaust gas pressure sensor 1 -G450-

Special tools and workshop equipment required

- ♦ Vehicle diagnosis, testing and information system -VAS 5051- with diagnosis cable -VAS 5051/6A-



Note

Other diagnosis testers can be used instead of the vehicle diagnosis, testing and information system.

Prerequisites

- Fuses must be OK.
- The battery voltage must be at least 11.5 V.
- Earth connection OK.
- All electrical consumers must be switched off.

Procedure

- Switch the ignition on and back off.
- Leave ignition switched on for at least 30 seconds.
- Repeat procedure 5 times.
- Then wait one minute for the control unit to run down.
- Connect vehicle diagnosis, testing and information system -VAS 5051- and select diagnosis function "011-Read data block". The ignition must be switched on for this purpose. (Connect fault reader and select engine control unit -J623- ⇒ [page 3](#)).
- Select "Display group 100".

Indicated on display:



Note

On the display of the vehicle diagnosis, testing and information system -VAS 5051- the display zones are displayed below one another and, next to one another on other diagnosis testers.

- Check specifications in display zones 3 and 4.
- Specification in display zone 3: -4...4 mbar
- Specification in display zone 4: -24...79 mbar

If the specifications are attained:

Adaption carried out successfully.

If the specifications are not attained

- Repeat procedure

If readings still do not match specifications:

- If necessary, renew pressure sensor -G450- ⇒ [page 266](#),
Assembly overview - particulate filter.

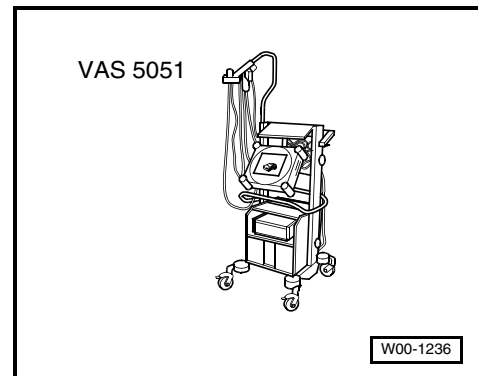

Display group 100			
xxx °C	xxx °C	xxx mbar	xxx mbar



3.4 Reading comparison values for amount injected (IDC/IVC) and writing to engine control unit

Note

With this function new IDC/IVC values can be adapted for the injectors. The 7-digit IDC/IVC values are marked on each injector.

Special tools and workshop equipment required

- ◆ Vehicle diagnosis, testing and information system -VAS 5051- with diagnosis cable -VAS 5051/6A-

Note

Other diagnosis testers can be used instead of the vehicle diagnosis, testing and information system.

Read out IDC/IVC values

- Connect vehicle diagnosis, testing and information system -VAS 5051- and select diagnosis function "014-Longer adaption". The ignition must be switched on for this purpose. (Connect fault reader and select engine control unit -J623- ⇒ [page 3](#)).
- Select respective "channel number" for injectors -N30...N33-.
- "Channel number 71" for injector 1 -N30-
- "Channel number 72" for injector 2 -N31-
- "Channel number 73" for injector 3 -N32-
- "Channel number 74" for injector 4 -N33-
- Compare prescribed 7-digit ASCII value with value printed on respective injector.
- If the values do not check-out, adapt IDC/IVC value to respective injector.

Writing IDC/IVC values to engine control unit.

Note

If an injector or the engine control unit was renewed, the 7-digit IDC/IVC value printed on the injector must be written to the engine control unit.

- Select respective "channel number" for injectors -N30...N33-.
- "Channel number 71" for injector 1 -N30-
- "Channel number 72" for injector 2 -N31-
- "Channel number 73" for injector 3 -N32-
- "Channel number 74" for injector 4 -N33-
- Press key **Keypad**.

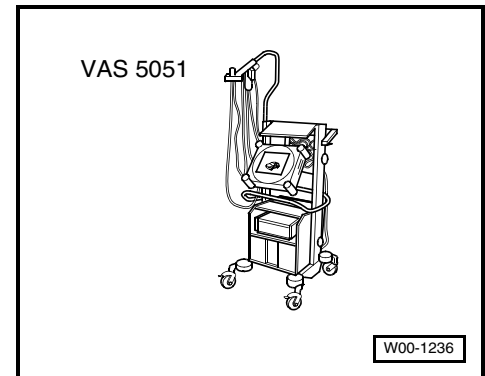



- Using screen keypad, enter 7-digit IDC/IVC value for respective injector.
- Press key.
- Press key **Store** to store IDC/IVC value to engine control unit.

3.5 Adapting engine control unit -J623- to position sender for charge pressure positioner -G581-



Note

If position sender for charge pressure positioner -G581- was renewed, it must be adapted to engine control unit -J623-.

Special tools and workshop equipment required

- ♦ Vehicle diagnosis, testing and information system -VAS 5051- with diagnosis cable -VAS 5051/6A-



Note

Other diagnosis testers can be used instead of the vehicle diagnosis, testing and information system.

Prerequisites

- Fuses must be OK.
- The battery voltage must be at least 11.5 V.
- Earth connection OK.
- All electrical consumers must be switched off.

Procedure

- Connect vehicle diagnosis, testing and information system -VAS 5051- and select diagnosis function "014-Longer adaption". The ignition must be switched on for this purpose. (Connect fault reader and select engine control unit -J623- ⇒ [page 3](#)).
- Select "Channel number 120":
- Press key **Keypad**.
- Enter value 1 via screen keyboard.
- Press key.
- Press key **Confirm** to reset learnt values.
- Then read fault memory of engine control unit and clear fault memory if necessary ⇒ [page 7](#), Clearing fault memory.

If a fault is stored in the fault memory:

- Check position sender for charge pressure positioner -G581- ⇒ [page 202](#).
- Erase fault memory ⇒ [page 8](#).
- Repeat procedure

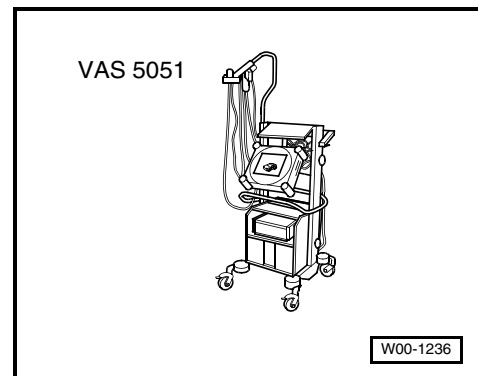



3.6 Adapting engine control unit -J623- to exhaust gas recirculation valve

Note

- ◆ If exhaust gas recirculation valve has been renewed, adaptation must be performed.
- ◆ The exhaust gas recirculation valve -N18- and exhaust gas recirculation potentiometer -G212- are installed together in a housing.

Special tools and workshop equipment required

- ◆ Vehicle diagnosis, testing and information system -VAS 5051- with diagnosis cable -VAS 5051/6A-

Note

Other diagnosis testers can be used instead of the vehicle diagnosis, testing and information system.

Prerequisites

- Fuses must be OK.
- The battery voltage must be at least 11.5 V.
- Earth connection OK.
- All electrical consumers must be switched off.

Procedure

- Connect vehicle diagnosis, testing and information system -VAS 5051- and select diagnosis function "014-Longer adaption". The ignition must be switched on for this purpose. (Connect fault reader and select engine control unit -J623- ⇒ [page 3](#)).
- Select "Channel number 123":
- Press key **Keypad**.
- Enter value 1 via screen keyboard.
- Press  key.
- Press key **Confirm** to reset learnt values.
- Then read fault memory of engine control unit and clear fault memory if necessary ⇒ [page 7](#), Clearing fault memory.

If a fault is stored in the fault memory:

- Check exhaust gas recirculation valve -N18- with exhaust gas recirculation potentiometer -G212- ⇒ [page 270](#).
- Erase fault memory ⇒ [page 8](#).
- Repeat procedure

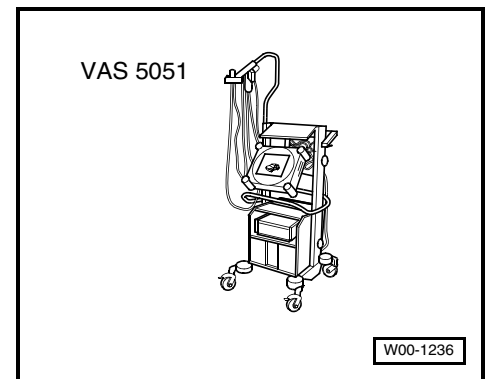



3.7 Adapting engine control unit -J623- to throttle valve module -J338-

Note

- ♦ If throttle valve module -J338- has been renewed, adaption must be performed.
- ♦ The throttle valve module -J338- and throttle valve potentiometer -G69- are installed together in a housing.

Special tools and workshop equipment required

- ♦ Vehicle diagnosis, testing and information system -VAS 5051- with diagnosis cable -VAS 5051/6A-

Note

Other diagnosis testers can be used instead of the vehicle diagnosis, testing and information system.

Prerequisites

- Fuses must be OK.
- The battery voltage must be at least 11.5 V.
- Earth connection OK.
- All electrical consumers must be switched off.

Procedure

- Connect vehicle diagnosis, testing and information system -VAS 5051- and select diagnosis function "014-Longer adaption". The ignition must be switched on for this purpose. (Connect fault reader and select engine control unit -J623- ⇒ [page 3](#)).
- Select "Channel number 124":
- Press key **Keypad**.
- Enter value 1 via screen keyboard.
- Press  key.
- Press key **Confirm** to reset learnt values.
- Then read fault memory of engine control unit and clear fault memory if necessary ⇒ [page 7](#), Clearing fault memory.

If a fault is stored in the fault memory:

- Check throttle valve module -J338- ⇒ [page 255](#).
- Erase fault memory ⇒ [page 8](#).
- Repeat procedure

3.8 Checking data bus

Note

Due to the various installation applications for industrial engines, the following section can only show the basic notes for tests.

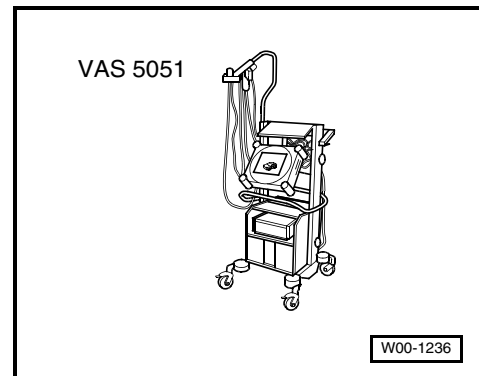



Operation

The engine control unit communicates with all data bus capable control units via a CAN data bus.

The data bus capable components are connected together via two data bus wires twisted together (CAN_High and CAN_Low) and exchange information (messages). Faulty information on the data bus are recognised as faults and are stored as such.

The data bus requires a matching resistor to function fault-free. This central matching resistor is located in the engine control unit.

Special tools and workshop equipment required

- ◆ Hand multimeter -V.A.G 1526- or multimeter -V.A.G 1715-
- ◆ Adapter set -V.A.G 1594-
- ◆ Test box -V.A.G 1598/42- with adapter cable -V.A.G 1598/39-2-
- ◆ Current flow diagram

Test prerequisite

- Ignition switched off
- A fault has been recognised by the CAN data bus self-diagnosis ⇒ [page 7](#), Reading fault memory.

Test procedure

- Pull 94-pin connector off engine control unit -J623-.
- Connect test box -V.A.G 1598/42- to engine control unit and to -connection A and B- on test box using adapter cable -V.A.G 1598/39-2-. The control unit wiring harness is not connected by this action.
- Check matching resistor in engine control unit:
- Connect multimeter using auxiliary cables from -V.A.G 1594- to measure resistance between following sockets of test box:
 - ◆ 67 + 68
- Specification: 60...72 Ω

If the specification is not attained:

- Renew engine control unit -J623- ⇒ [page 259](#).

If specification is attained:

- Eliminate the fault in wiring and in other data bus components according to current flow diagrams ⇒ [page 305](#).
- Then read fault memory of engine control unit and clear fault memory if necessary ⇒ [page 7](#), Clearing fault memory.



26 – Exhaust system

1 Removing and installing parts of exhaust system

Note

- ◆ Due to the various installation applications for industrial engines, the following section can only show the basic notes.
- ◆ After working on the exhaust system, ensure that the system is not under stress and that there is sufficient clearance to the bodywork. If necessary, align silencer and exhaust pipe so that sufficient clearance is maintained to the bodywork and the mountings are evenly loaded.
- ◆ Renew self-locking nuts.

Assembly overview - particulate filter ⇒ [page 266](#)

1.1 Assembly overview - particulate filter

1 - Exhaust gas pressure sensor 1 -G450-

- Checking
⇒ [page 280](#).

2 - 10 Nm

3 - Shield

4 - Lambda probe -G39-

- 50 Nm
- Grease only the threads with high-temperature paste -G 052 112 A3-; high-temperature paste -G 052 112 A3- must not get into the slots of probe body.
- To remove use Lambda probe opening spanner set -3337-.
- Checking
⇒ [page 272](#).

5 - Exhaust gas temperature sender 4 -G648-, 45 Nm

- (Exhaust gas temperature sender after particulate filter)
- Lubricate thread of sender with high-temperature paste -G 052 112 A3-
- Checking ⇒ [page 277](#).

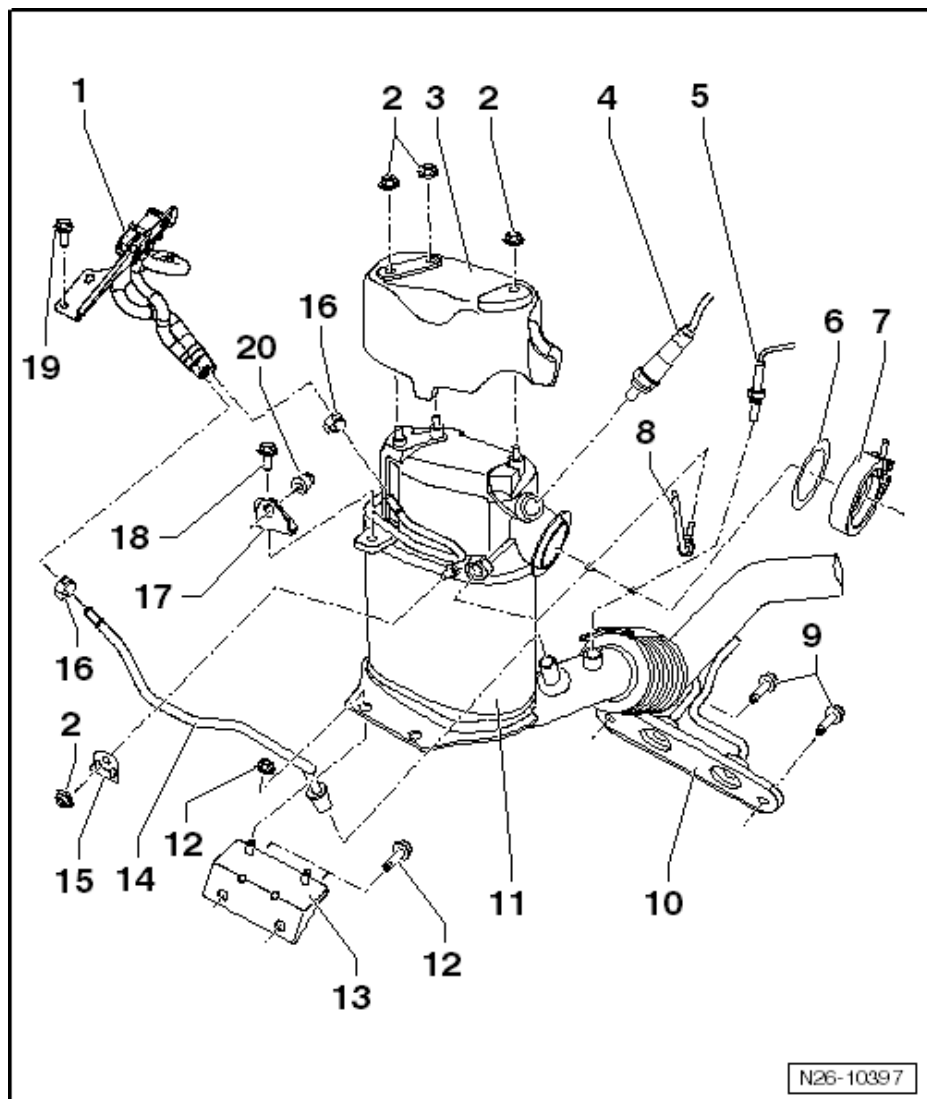



- 6 - Gasket**
 - Renew.
 - Note installation position.
- 7 - Clamp, 7 Nm**
 - Check for secure seating
- 8 - Exhaust gas temperature sender 3 -G495-, 45 Nm**
 - (Exhaust gas temperature sender before particulate filter)
 - Lubricate thread of sender with high-temperature paste -G 052 112 A3-
 - Checking ⇒ [page 275](#).
- 9 - 25 Nm**
- 10 - Mounting**
 - Renew if damaged.
- 11 - Particulate filter**
 - With oxidation catalytic converter.
 - Check particulate filter ⇒ [page 282](#)
 - After renewing particulate filter, the adaption of ash mass values must be set to "0" ⇒ [page 282](#),
Checking particulate filter.
- 12 - 25 Nm**
- 13 - Bracket**
 - Bolted to cylinder block.
- 14 - Control line, 45 Nm**
- 15 - Bracket**
 - Bolted to diesel particulate filter
- 16 - Clamp**
 - Renew.
- 17 - Bracket**
 - Bolted to cylinder head.
- 18 - 25 Nm**
- 19 - 8 Nm**
- 20 - 25 Nm**

2 Exhaust gas recirculation system

Note

- ◆ *Due to the various installation applications for industrial engines, the following section can only show the basic notes.*
- ◆ *Renew self-locking nuts.*

Assembly overview - exhaust gas recirculation cooler
⇒ [page 267](#).

Vacuum hose schematic diagram ⇒ [page 194](#).

2.1 Assembly overview - exhaust gas recirculation cooler

- Note safety precautions before beginning work
⇒ [page 208](#).
- Observe rules for cleanliness ⇒ [page 208](#).



1 - Gasket

- Renew.
- Note installation position.

2 - Connecting pipe



Caution!

Ensure decoupling element of connecting pipe is not bent and thus stretched. There is a danger of cracking.

3 - 8 Nm

4 - Radiator

- For exhaust gas recirculation.

5 - Connecting pipe



Caution!

Ensure decoupling element of connecting pipe is not bent and thus stretched. There is a danger of cracking.

6 - 23 Nm

7 - Exhaust gas recirculation valve -N18- with exhaust gas recirculation potentiometer -G212-

- Mark installation position before removal.

- Before installation, thoroughly clean fitting area on valve and housing, oil lightly as required.
- Checking ⇒ [page 47](#), final control diagnosis

8 - Coolant hose

- Check for secure seating.

9 - Housing

- For exhaust gas recirculation valve

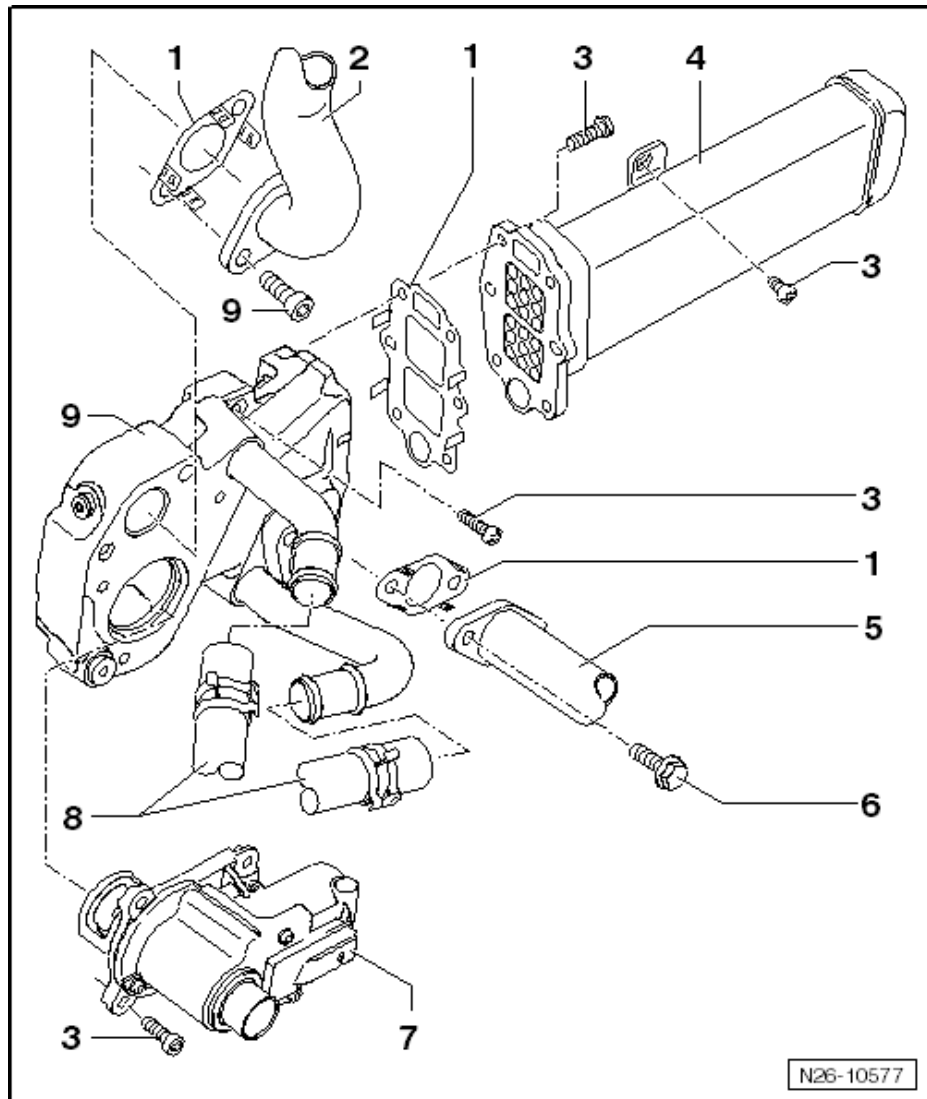

3 Checking components and functions

The component, functional tests and reference to current flow diagrams ⇒ [page 305](#) are for standard components.

Refer to notes/instructions from respective clients of industrial engines for deviations with components and current flow diagrams.

Checking exhaust gas recirculation system ⇒ [page 269](#).



Checking adaption of exhaust gas recirculation valve -N18-
⇒ [page 263](#).

Checking exhaust gas recirculation valve -N18- ⇒ [page 270](#).

Checking Lambda probe -G39- ⇒ [page 272](#).

Checking Lambda probe heater -Z19- ⇒ [page 274](#).

Checking exhaust gas temperature sender 3 -G495- (exhaust
gas temperature sender before turbocharger) ⇒ [page 275](#).

Checking exhaust gas temperature sender 4 -G648- (exhaust
gas temperature sender after turbocharger) ⇒ [page 277](#).

Checking exhaust gas pressure sensor 1 -G450- ⇒ [page 280](#).

Checking particulate filter ⇒ [page 282](#).

3.1 Checking exhaust gas recirculation

Note

The check of the exhaust gas recirculation is performed in diagnosis function "05-Final control diagnosis". This procedure causes the exhaust gas recirculation valve -N18- to be pulsed, to permit data block readings of extreme values for exhaust gas recirculation.

Special tools and workshop equipment required

- ◆ Vehicle diagnosis, testing and information system
-VAS 5051- with diagnosis cable -VAS 5051/6A-

Note

Other diagnosis testers can be used instead of the vehicle diagnosis, testing and information system.

Test prerequisites

- Fuses must be OK.
- The battery voltage must be at least 11.5 V.
- All electrical consumers must be switched off.
- Earth connection OK.
- No leaks on intake and exhaust systems.
- No faults in engine, fuel injection system or compression pressures.
- No faults must be stored in fault memory ⇒ [page 7](#), Reading fault memory.
- Coolant temperature must be at least 80 °C, ⇒ display group 1, display zone 4.

Test procedure

- Carry out final control diagnosis and actuate exhaust gas recirculation valve -N18- ⇒ [page 47](#), Final control diagnosis.

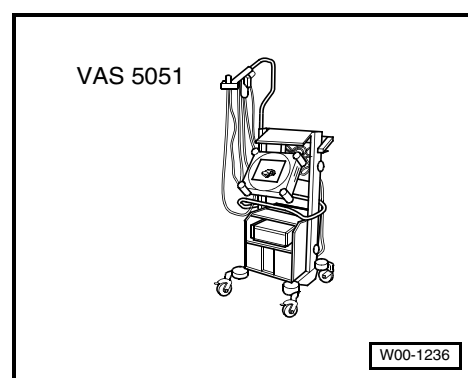



The displays in display zones 3 and 4 must fluctuate within following control range:

- Specification in display zone 3: 180...470 mg/H
- Specification in display zone 4: 70...100 %



Note

The activation of the valve can be checked by touch.

- Proceed with final control diagnosis until completed.
- Terminate diagnosis function.
- Switch off ignition.

If the specifications are not attained

- Check exhaust gas recirculation valve -N18- ⇒ [page 270](#).
- Check vacuum hoses for leaks. Vacuum hose schematic diagram ⇒ [page 194](#).

3.2 Checking exhaust gas recirculation valve -N18-

Special tools and workshop equipment required

- ♦ Vehicle diagnosis, testing and information system -VAS 5051- with diagnosis cable -VAS 5051/6A-
- ♦ Hand multimeter -V.A.G 1526- or multimeter -V.A.G 1715-
- ♦ Adapter set -V.A.G 1594-
- ♦ Test box -V.A.G 1598/42- with adapter cable -V.A.G 1598/39-1-
- ♦ Current flow diagram



Note

Other diagnosis testers can be used instead of the vehicle diagnosis, testing and information system.

Test prerequisites

- Fuses must be OK.
- The battery voltage must be at least 11.5 V.
- All electrical consumers must be switched off.
- Earth connection OK.
- Coolant temperature must be at least 80 °C, ⇒ display group 1, display zone 4.

Test procedure

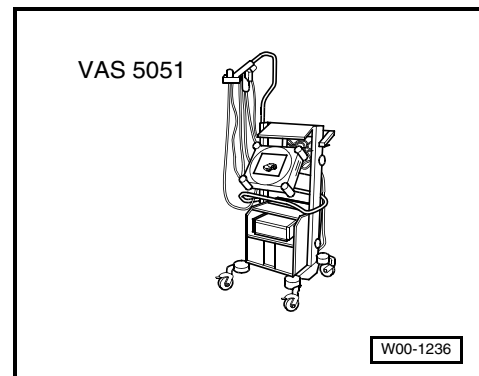



i Note

- ◆ The exhaust gas recirculation valve -N18- and exhaust gas recirculation potentiometer -G212- are installed together in a housing.
- ◆ Only gold-plated contacts may be used when repairing the exhaust gas recirculation valve connector contacts.
- Carry out final control diagnosis and actuate exhaust gas recirculation valve -N18- → page 47, Final control diagnosis.

The displays in display zones 3 and 4 must fluctuate within following control range:

- Specification in display zone 3: 180...470 mg/H
- Specification in display zone 4: 70...100 %

i Note

The activation of the valve can be checked by touch.

- Proceed with final control diagnosis until completed.
- Terminate diagnosis function.
- Switch off ignition.

If the valve is not activated:

- Pull 6-pin connector off exhaust gas recirculation valve -N18- with exhaust gas recirculation potentiometer -G212- ⇒ item 7 on page 268.

Checking voltage supply

- Switch on ignition.
- Connect multimeter to measure voltage at following connector contacts and engine earth using auxiliary cables from -V.A.G 1594-.
- ◆ Contact 1 + engine earth
- ◆ Contact 1 + contact 3
- Specification: At least 4.8... 5.2 V
- Switch off ignition.
- Check wiring from exhaust gas recirculation valve -N18- with exhaust gas recirculation potentiometer -G212- as follows:
- Connect test box -V.A.G 1598/42- to control unit wiring harness ⇒ page 5 using adapter cable -V.A.G 1598/39-1-. The engine control unit is not connected by this action.

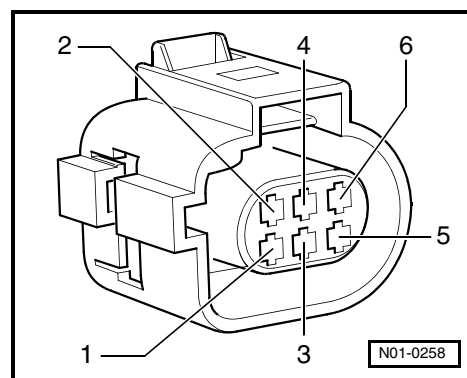



- Check wiring between test box and connector for open circuit referring to current flow diagram.
- ◆ Contact 1 + socket 25
- ◆ Contact 2 + socket 19
- ◆ Contact 3 + socket 53
- ◆ Contact 5 + socket 57
- ◆ Contact 6 + socket 4
- Wire resistance: max. 2.0 Ω
- Also check wiring for short to one another, to battery earth/engine earth and to battery positive. Specification: ∞ Ω.

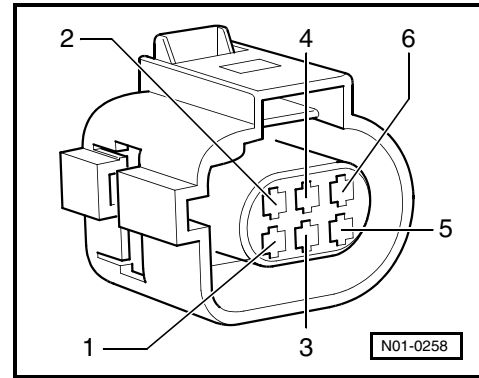

If no wiring fault is detected and voltage was present between contacts 1 + engine earth and 1 + 3:

- Renew exhaust gas recirculation valve -N18- with exhaust gas recirculation potentiometer -G212-.
- Perform adaption of exhaust gas recirculation valve -N18- ⇒ [page 263](#).
- Then read fault memory of engine control unit and clear fault memory if necessary ⇒ [page 7](#), Clearing fault memory.

If no wiring fault is detected and no voltage was present between contacts 1 + engine earth and 1 + 3:

- Pull connectors off all components which are connected to this voltage supply line ⇒ [page 305](#), Current flow diagram.
- Check voltage supply and wiring for all these components.

If no wiring fault is detected and no voltage was present at these components:

- Renew engine control unit -J623- ⇒ [page 259](#).

3.3 Checking Lambda probe -G39-

Special tools and workshop equipment required

- ◆ Hand multimeter -V.A.G 1526- or multimeter -V.A.G 1715-
- ◆ Adapter set -V.A.G 1594-
- ◆ Test box -V.A.G 1598/42- with adapter cable -V.A.G 1598/39-2-
- ◆ Current flow diagram

Test prerequisites

- Fuses must be OK.
- The battery voltage must be at least 11.5 V.
- All electrical consumers must be switched off.
- Earth connection OK.



- The exhaust system must not leak.
- Lambda probe heater -Z19- OK., Checking ⇒ [page 274](#).

Test procedure



Note

- ◆ *The Lambda probe -G39- and Lambda probe heater -Z19- are installed together in a housing.*
 - ◆ *Only gold-plated contacts may be used when repairing the Lambda probe and Lambda probe heater connector contacts.*
- Disconnect 6-pin connector from Lambda probe -G39- ⇒ [page 266](#).

Checking basic voltage

- Connect multimeter using auxiliary cables from -V.A.G 1594- to measure voltage at connector contacts 2 + 6.
- Switch on ignition. Check basis voltage after approx. 8 seconds. Specification: 0.4...0.5 V.
- Switch off ignition.

If the specification is not attained:

- Check Lambda probe wiring as follows:
- Connect test box -V.A.G 1598/42- to control unit wiring harness ⇒ [page 5](#) using adapter cable -V.A.G 1598/39-2-. The engine control unit is not connected by this action.
- Check wiring between test box and connector for open circuit referring to current flow diagram.
- ◆ Contact 1 + socket 77
 - ◆ Contact 2 + socket 56
 - ◆ Contact 5 + socket 55
 - ◆ Contact 6 + socket 78
- Wire resistance: max. 2.0 Ω
- Additionally check wires for short to one another. Specification: ∞ Ω.

If no wiring fault is detected and voltage was present between contacts 2 + 6:

- Renew Lambda probe -G39- ⇒ [page 266](#), Assembly overview - particulate filter.
- Then read fault memory of engine control unit and clear fault memory if necessary ⇒ [page 7](#), Clearing fault memory.

If no wiring fault is detected and no voltage was present between contacts 2 + 6:

- Renew engine control unit -J623- ⇒ [page 259](#).

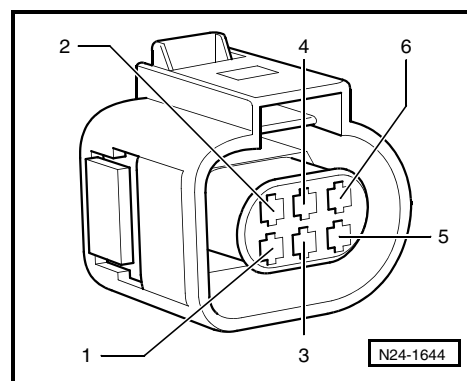
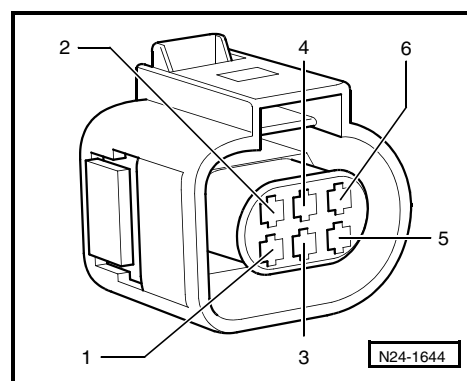



3.4 Checking Lambda probe heater -Z19-

Special tools and workshop equipment required

- ◆ Hand multimeter -V.A.G 1526- or multimeter -V.A.G 1715-
- ◆ Adapter set -V.A.G 1594-
- ◆ Test box -V.A.G 1598/42- with adapter cable -V.A.G 1598/39-2-
- ◆ Current flow diagram

Test prerequisites

- Fuses must be OK.
- The battery voltage must be at least 11.5 V.
- All electrical consumers must be switched off.
- Earth connection OK.

Test procedure



Note

- ◆ *The Lambda probe heater -Z19- and Lambda probe -G39- are installed together in a housing.*
 - ◆ *Only gold-plated contacts may be used when repairing the Lambda probe and Lambda probe heater connector contacts.*
- Disconnect 6-pin connector from Lambda probe -G39- ⇒ [page 266](#).

Checking resistance

- Connect multimeter to measure resistance at connector contacts 3 + 4 to Lambda probe heater using auxiliary cables from -V.A.G 1594-. Specification: max. 25.0 Ω (at ambient temperature).

If the specification is not attained:

- Renew Lambda probe -G39- ⇒ [page 266](#), Assembly overview - particulate filter.
- Then read fault memory of engine control unit and clear fault memory if necessary ⇒ [page 7](#), Clearing fault memory.

If specification is attained:

Checking voltage supply

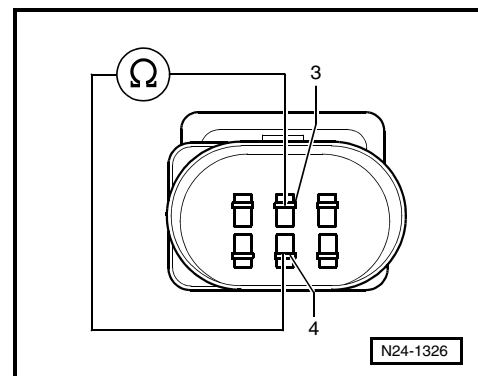



- Connect multimeter to measure voltage at connector contact 4 and engine earth using auxiliary cables from -V.A.G 1594-.
- Switch on ignition. Specification: At least 11.5 V.
- Switch off ignition.

If the specification is not attained:

- Check terminal 30 voltage supply relay -J317- ⇒ [page 305](#), Current flow diagram.
- Check cable connections for open circuit, short circuit and transfer resistance at contacts according to current flow diagram.

If specification is attained:

- Check Lambda probe heater wiring as follows:
- Connect test box -V.A.G 1598/42- to control unit wiring harness ⇒ [page 5](#) using adapter cable -V.A.G 1598/39-2-. The engine control unit is not connected by this action.
- Check wiring between test box and connector for open circuit referring to current flow diagram.

◆ Contact 3 + socket 73

● Wire resistance: max. 2.0 Ω

- Additionally check wires for short to one another. Specification: ∞ Ω.

If no wiring fault is detected and voltage supply is OK:

- Renew engine control unit -J623- ⇒ [page 259](#).

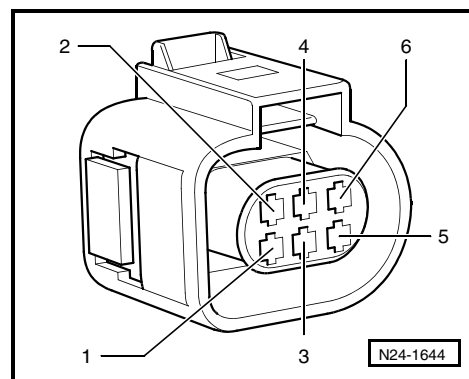
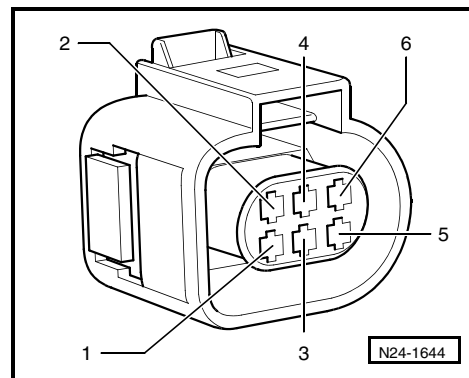

3.5 Checking exhaust gas temperature sender 3 -G495- (exhaust gas temperature sender before particulate filter)

Special tools and workshop equipment required

- ◆ Vehicle diagnosis, testing and information system -VAS 5051- with diagnosis cable -VAS 5051/6A-
- ◆ Hand multimeter -V.A.G 1526- or multimeter -V.A.G 1715-
- ◆ Adapter set -V.A.G 1594-
- ◆ Test box -V.A.G 1598/42- with adapter cable -V.A.G 1598/39-2-
- ◆ Current flow diagram

Note

Other diagnosis testers can be used instead of the vehicle diagnosis, testing and information system.

Test prerequisites

- Fuses must be OK.
- The battery voltage must be at least 11.5 V.

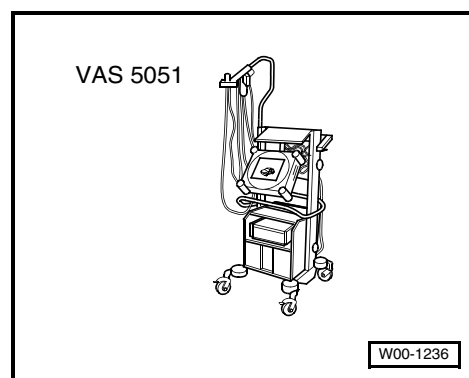



- All electrical consumers must be switched off.
- Earth connection OK.
- Engine must be cold

Test procedure

Note

Only gold-plated contacts may be used when repairing the exhaust gas temperature sender 3 connector contacts.

- Connect vehicle diagnosis, testing and information system -VAS 5051- and select diagnosis function "011-Read data block". the engine must be idling when doing so. (Connect vehicle diagnosis, testing and information system and select engine control unit ⇒ [page 3](#)).
- Select "Display group 99".

Indicated on display:

Note

On the display of the vehicle diagnosis, testing and information system -VAS 5051- the display zones are displayed below one another and, next to one another on other diagnosis testers.

- Increase engine speed to 2400...2800 rpm.
- Check exhaust gas temperature value from exhaust gas temperature sender 1 -G235- in display zone 2. The temperature value must increase uniformly and without interruption.
- Hold engine speed at 2400...2800 rpm for approx. 3 minutes.
- Select, at an increased engine speed, "Display group 100".

Note

Note temperature value in display zone 2.

Indicated on display:

- Check exhaust gas temperature value of exhaust gas temperature sender 3 -G495- (exhaust gas temperature sender before particulate filter) in display zone 1 and of exhaust gas temperature sender 4 -G648- (exhaust gas temperature sender after particulate filter) in display zone 2.

Note

- ♦ *The exhaust gas temperature in display zone 2 of display group 99 must be higher than exhaust gas temperature values in display zones 1 and 2 of display group 100.*
- ♦ *The exhaust gas temperature in display zone 1 of display group 100 must also be higher than exhaust gas temperature value in display zone 2 of display group 100.*

Display group 99			
880 rpm	114.0 °C	xxx.x °C	xxx.x °C

Display group 100			
xxx °C	xxx °C	xxx mbar	xxx mbar



- If, in display group 100, the value of display zone 2 is higher than value in display zone 1, both senders are interchanged.
- If in display zones 1 and 2 in display group 100 no realistic display is shown, check exhaust gas temperature sender 3 -G495- (exhaust gas temperature sender before particulate filter) and wiring to sender as follows:
- Terminate diagnosis function.
- Switch off ignition.

Checking resistance

- Disconnect 2-pin connector for exhaust gas temperature sender 3 -G495- ⇒ **item 8 on page 267**.
- Connect multimeter to measure resistance at contacts to sender using auxiliary cables from -V.A.G 1594-. Specification: 170,0...850,0 Ω.

If the specification is not attained:

- Renew exhaust gas temperature sender 3 -G495- ⇒ **item 8 on page 267**.
- Then read fault memory of engine control unit and clear fault memory if necessary ⇒ **page 7**, Clearing fault memory.

If specification is attained:

- Check exhaust gas temperature sender 3 -G495- wiring as follows:
- Connect test box -V.A.G 1598/42- to control unit wiring harness ⇒ **page 5** using adapter cable -V.A.G 1598/39-2-. The engine control unit is not connected by this action.
- Check wiring between test box and connector for open circuit referring to current flow diagram.
- ◆ Contact 1 + socket 89
- ◆ Contact 2 + socket 32
- Wire resistance: max. 2.0 Ω
- Also check wiring for short to one another, to battery earth/engine earth and to battery positive. Specification: ∞ Ω.

If no fault in lines is detected:

- Renew engine control unit -J623- ⇒ **page 259**.

3.6 Checking exhaust gas temperature sender 4 -G648- (exhaust gas temperature sender after particulate filter)

Special tools and workshop equipment required

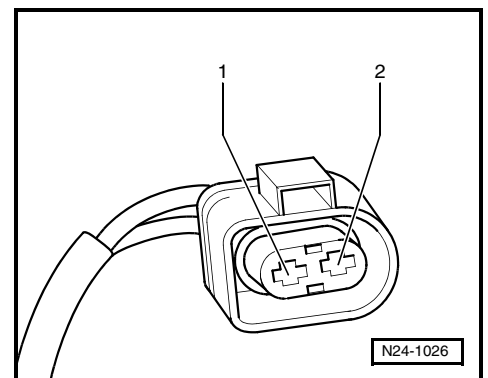
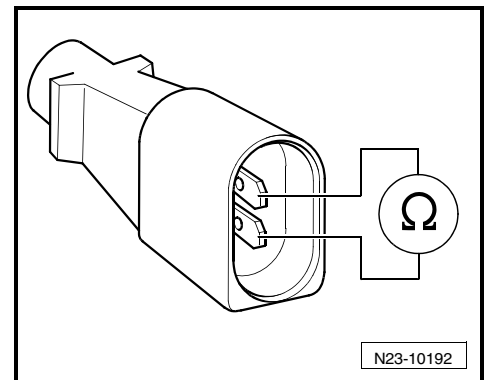



- ◆ Vehicle diagnosis, testing and information system -VAS 5051- with diagnosis cable -VAS 5051/6A-
- ◆ Hand multimeter -V.A.G 1526- or multimeter -V.A.G 1715-
- ◆ Adapter set -V.A.G 1594-
- ◆ Test box -V.A.G 1598/42- with adapter cable -V.A.G 1598/39-2-
- ◆ Current flow diagram

i Note

Other diagnosis testers can be used instead of the vehicle diagnosis, testing and information system.

Test prerequisites

- Fuses must be OK.
- The battery voltage must be at least 11.5 V.
- All electrical consumers must be switched off.
- Earth connection OK.
- Engine must be cold

Test procedure

i Note

Only gold-plated contacts may be used when repairing the exhaust gas temperature sender 4 connector contacts.

- Connect vehicle diagnosis, testing and information system -VAS 5051- and select diagnosis function "011-Read data block". the engine must be idling when doing so. (Connect vehicle diagnosis, testing and information system and select engine control unit ⇒ [page 3](#)).
- Select "Display group 99".

Indicated on display:

i Note

On the display of the vehicle diagnosis, testing and information system -VAS 5051- the display zones are displayed below one another and, next to one another on other diagnosis testers.

- Increase engine speed to 2400...2800 rpm.
- Check exhaust gas temperature value from exhaust gas temperature sender 1 -G235- in display zone 2. The temperature value must increase uniformly and without interruption.
- Hold engine speed at 2400...2800 rpm for approx. 3 minutes.

i Note

Note temperature value in display zone 2.

- Select, at an increased engine speed, "Display group 100".

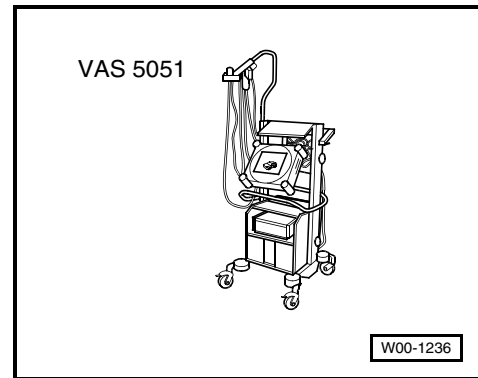

Display group 99			
880 rpm	114.0 °C	xxx.x °C	xxx.x °C



Indicated on display:

- Check exhaust gas temperature value of exhaust gas temperature sender 3 -G495- (exhaust gas temperature sender before particulate filter) in display zone 1 and of exhaust gas temperature sender 4 -G648- (exhaust gas temperature sender after particulate filter) in display zone 2.

Display group 100			
xxx °C	xxx °C	xxx mbar	xxx mbar

i Note

- ◆ *The exhaust gas temperature in display zone 2 of display group 99 must be higher than exhaust gas temperature values in display zones 1 and 2 of display group 100.*
- ◆ *The exhaust gas temperature in display zone 1 of display group 100 must also be higher than exhaust gas temperature value in display zone 2 of display group 100.*
- If, in display group 100, the value of display zone 2 is higher than value in display zone 1, both senders are interchanged.
- If in display zones 1 and 2 in display group 100 no realistic display is shown, check exhaust gas temperature sender 4 -G648- (exhaust gas temperature sender after particulate filter) and wiring to sender as follows:
 - Terminate diagnosis function.
 - Switch off ignition.

Checking resistance

- Disconnect 2-pin connector for exhaust gas temperature sender 4 -G648- ⇒ [item 5 on page 266](#).
- Connect multimeter to measure resistance at contacts to sender using auxiliary cables from -V.A.G 1594-. Specification: 170,0...850,0 Ω.

If the specification is not attained:

- Renew exhaust gas temperature sender 4 -G648- ⇒ [item 5 on page 266](#).
- Then read fault memory of engine control unit and clear fault memory if necessary ⇒ [page 7](#), Clearing fault memory.

If specification is attained:

- Check exhaust gas temperature sender 4 -G648- wiring as follows:
 - Connect test box -V.A.G 1598/42- to control unit wiring harness ⇒ [page 5](#) using adapter cable -V.A.G 1598/39-2-. The engine control unit is not connected by this action.

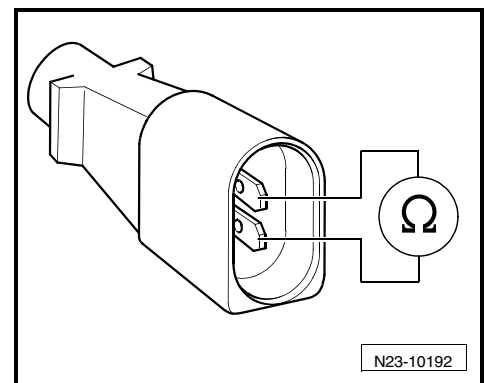



- Check wiring between test box and connector for open circuit referring to current flow diagram.
- ◆ Contact 1 + socket 89
- ◆ Contact 2 + socket 75
- Wire resistance: max. 2.0 Ω
- Also check wiring for short to one another, to battery earth/engine earth and to battery positive. Specification: ∞ Ω.

If no fault in lines is detected:

- Renew engine control unit -J623- ⇒ [page 259](#).

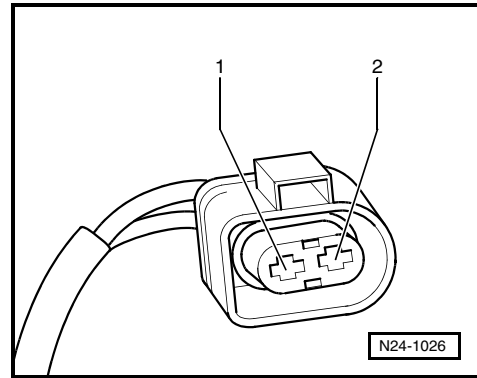

3.7 Checking exhaust gas pressure sensor 1 -G450-

Special tools and workshop equipment required

- ◆ Vehicle diagnosis, testing and information system -VAS 5051- with diagnosis cable -VAS 5051/6A-
- ◆ Hand multimeter -V.A.G 1526- or multimeter -V.A.G 1715-
- ◆ Adapter set -V.A.G 1594-
- ◆ Test box -V.A.G 1598/42- with adapter cable -V.A.G 1598/39-2-
- ◆ Current flow diagram



Note

Other diagnosis testers can be used instead of the vehicle diagnosis, testing and information system.

Test prerequisites

- Fuses must be OK.
- The battery voltage must be at least 11.5 V.
- All electrical consumers must be switched off.
- Earth connection OK.
- Control line between exhaust gas pressure sensor 1 and particulate filter may not be blocked or damaged, Checking ⇒ [page 266](#), Assembly overview - particulate filter.

Test procedure



Note

Only gold-plated contacts may be used when repairing the exhaust gas pressure sender 1 connector contacts.

- Connect vehicle diagnosis, testing and information system -VAS 5051- and select diagnosis function "011-Read data block". the engine must be idling when doing so. (Connect vehicle diagnosis, testing and information system and select engine control unit ⇒ [page 3](#)).
- Select "Display group 100".

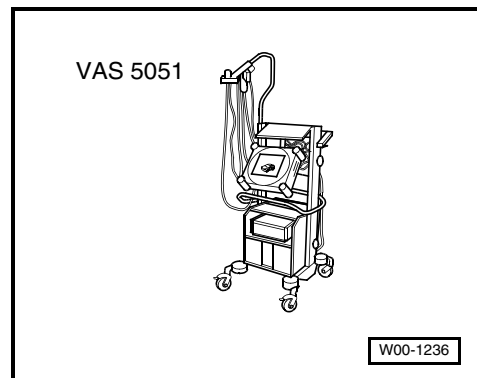



Indicated on display:

Display group 100
xxx.x °C xxx.x °C 4.20 mbar x.xx mbar

i Note

On the display of the vehicle diagnosis, testing and information system -VAS 5051- the display zones are displayed below one another and, next to one another on other diagnosis testers.

- Check exhaust gas differential pressures (actual) in display zone 3.
- Increase engine speed to 2500...2800 rpm.
- Check exhaust gas differential pressures (actual) in display zone 3. Specification: The exhaust gas differential pressure should increase dramatically.
- Terminate diagnosis function.
- Switch off ignition.

If the exhaust gas differential pressures (actual) in display zone 3 remain constantly at 0 mbar:

- Check particulate filter for cracks ⇒ [page 266](#), Assembly overview - particulate filter.

If the exhaust gas differential pressures (actual) in display zone 3 are not constantly at 0 mbar and the values are not as described:

Checking voltage supply

- Pull 3-pin connector -1- off exhaust gas pressure sensor 1 -G450-.

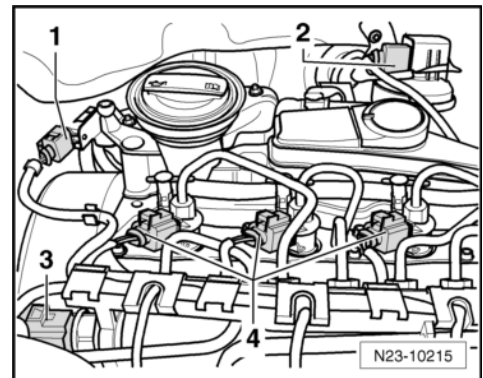

- Connect multimeter using auxiliary cables from -V.A.G 1594- to measure voltage at connector contacts 1 + 2.
- Switch on ignition. Specification: At least 4.8... 5.2 V.
- Switch off ignition.
- Check exhaust gas pressure sender 1 wiring as follows:
- Connect test box -V.A.G 1598/42- to control unit wiring harness ⇒ [page 5](#) using adapter cable -V.A.G 1598/39-2-. The engine control unit is not connected by this action.

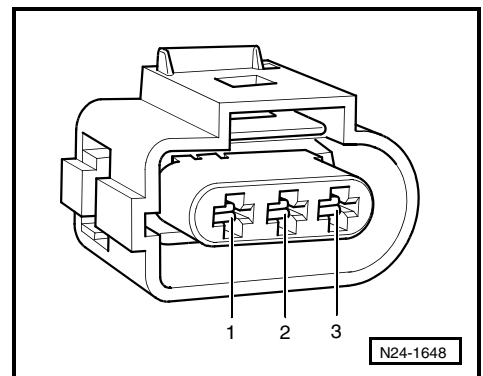



- Check wiring between test box and connector for open circuit referring to current flow diagram.
- ◆ Contact 1 + socket 14
- ◆ Contact 2 + socket 79
- ◆ Contact 3 + socket 34
- Wire resistance: max. 2.0 Ω
- Also check wiring for short to one another, to battery earth/engine earth and to battery positive. Specification: ∞ Ω.

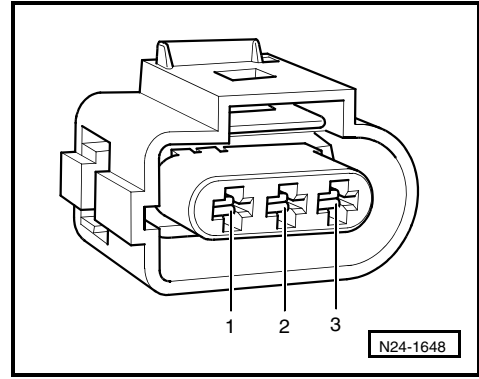

If no wiring fault is detected and voltage was present between contacts 1 + 2:

- Renew exhaust gas pressure sensor 1 -G450-
⇒ [page 266](#), Assembly overview - particulate filter.
- Adapt new exhaust gas pressure sensor 1 -G450-
⇒ [page 260](#).
- Then read fault memory of engine control unit and clear fault memory if necessary ⇒ [page 7](#), Clearing fault memory.

If no wiring fault is detected and no voltage was present between contacts 1 + 2:

- Pull connectors off all components which are connected to this voltage supply line ⇒ [page 305](#), Current flow diagram.
- Check voltage supply and wiring for all these components.

If no wiring fault is detected and no voltage was present at these components:

- Renew engine control unit -J623- ⇒ [page 259](#).

3.8 Checking particulate filter



Note

- ◆ If the particulate filter is renewed, the adaption of ash mass values must be set to "0" ⇒ [page 286](#), Checking particulate filter.
- ◆ If the engine control unit has been renewed, write previously read-out odometer reading to control unit ⇒ [page 287](#).



Special tools and workshop equipment required

- ◆ Vehicle diagnosis, testing and information system
-VAS 5051- with diagnosis cable -VAS 5051/6A-

Note

Other diagnosis testers can be used instead of the vehicle diagnosis, testing and information system.

Test prerequisites

- Fuses must be OK.
- The battery voltage must be at least 11.5 V.
- All electrical consumers must be switched off.
- Earth connection OK.
- Exhaust gas temperature sender 1 -G235- (exhaust gas temperature sender before turbocharger) OK., Checking ⇒ [page 204](#).
- Exhaust gas temperature sender 3 -G495- (exhaust gas temperature sender before particulate filter) OK., Checking ⇒ [page 275](#).
- Exhaust gas temperature sender 4 -G648- (exhaust gas temperature sender after particulate filter) OK., Checking ⇒ [page 277](#).

Test procedure

Reading kilometres since last regeneration

- Switch on ignition.
- Connect vehicle diagnosis, testing and information system -VAS 5051- and select diagnosis function “011-Read data block”. (Connect vehicle diagnosis, testing and information system and select engine control unit ⇒ [page 3](#)).
- Select “Display group 106”.

Indicated on display:

Note

On the display of the vehicle diagnosis, testing and information system -VAS 5051- the display zones are displayed below one another and, next to one another on other diagnosis testers.

Read out kilometres since last regeneration in display zone 3.

- Check kilometres since last regeneration.

Evaluating filter status

- Start engine.
- Press key.
- Select “Display group 1”.
- Increase engine speed to 1200... 1500 rpm.
- Maintain increased engine speed for approx. 10 minutes and then allow engine to run at idling speed.

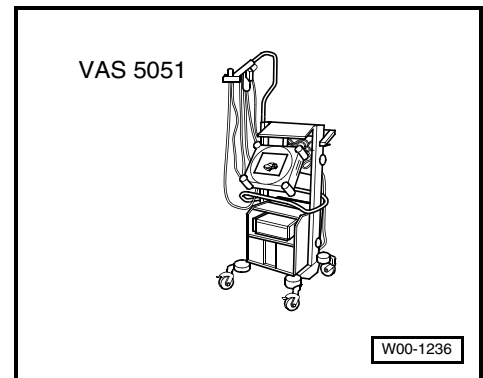

Display group 106			
xxxx	xx l	xxxx km	xxxx

Display group 1			
880 rpm	xxx.x mg/H	xxxx bar	53.3 °C



- Check value for coolant temperature in display zone 4.
Specification: at least 80°C.

Do not continue with check until coolant temperature has been reached.

- Press key.
- Select “Display group 108”.

Indicated on display:

Display group 108		
110 ml	30.0 g	30.0 g

- Check value for soot saturation in display zone 1. Specification: max. 175 ml.
- Check calculated value for soot mass in display zone 2. Specification: max. 40.0 g.
- Check read value for soot mass in display zone 3. Specification: max. 40.0 g.



Note

The DPF warning lamp lights-up at a soot saturation level of more than 30.0 g.



DANGER!

If the soot saturation level in display zones 2 and 3 lie above 40 g, on no account may a regeneration be started! Risk of fire.

If the soot saturation level in display zones 2 and 3 lie between 30.0... 37 g:

- Perform regeneration of particulate filter ⇒ [page 284](#).

If soot saturation in display zone 1 is above 175 ml:

or

If soot saturation in display zones 2 or 3 is above 40.0 g:

- Terminate diagnosis function.
- Switch off ignition.
- Renew particulate filter ⇒ [page 286](#).

Regeneration of particulate filter



Note

- ♦ A regeneration of the particulate filter is first possible above a coolant temperature of at least 80°C and an exhaust gas temperature before particulate filter of at least 161 °C.
- ♦ The regeneration takes 10 minutes.
- Start engine and run at idling speed.
- Select diagnosis function “011-Read data block”.
- Select “Display group 1”.

Indicated on display:

Display group 1			
880 rpm	xxx.x mg/H	xxxx bar	53.3 °C



- Check value for coolant temperature in display zone 4.
Specification: at least 80 °C.
- Increase engine speed to above 1500 rpm.

Do not continue with check until coolant temperature has been reached.

- Press key.
- Select “Display group 100”.

Indicated on display:

Display group 100			
xxx °C	xxx °C	xxx mbar	xxx mbar

- Check exhaust gas temperature value from exhaust gas temperature sender 3 -G495- (exhaust gas temperature sender before particulate filter) in display zone 1. Specification: at least 161 °C.

Do not continue with check until exhaust temperature before particulate filter has been reached.



Note

- ◆ *When checking engine during a road test/trial run, accelerate engine from 1500 rpm at full throttle. Observe prerequisites for measurements at full load/throttle ⇒ [page 65](#).*
- ◆ *The measured values must be read (2nd person required) when the revolutions reach 2800 rpm.*
- ◆ *Test and measuring instruments must be secured and operated by a second person.*

- Start service generation as follows:
- Press key twice.

Select diagnostic function “015-Access authorization”.

- Enter following access code.
- Access code: 40809
- Confirm access code.
- Press key three times.

Select diagnosis function “014-Longer adaptation”.

- Select “Channel number 13”:
- Enter adaption value “1”.
- Confirm value with key .
- Press key twice.
- Select diagnosis function “011-Read data block”.
- Select “Display group 108”.
- During a road test, increase engine speed from approx. 1500 rpm under full throttle (accelerator position sender on full throttle stop).
- Have a second person read off the values at approx. 2800 rpm,



Indicated on display:

Display group 108			
110 ml	30.0 g	30.0 g	

i Note

During a service regeneration, the values in display zones 2 and 3 should be lower.

- Check value for soot saturation in display zones 2 and 3. Specification: Less than 5g.

If specification is attained:

- Press key.
- Select "Display group 106".

Indicated on display:

Display group 106			
xxxx	xx l	xxxx km	xxxx

- Check quantity of fuel consumed since last regeneration in display zone 2: Specification: 0
- Check time since last regeneration in display zone 4: Specification: 0

i Note

- ♦ *When the specifications are attained the regeneration of the particulate filter has been successful.*
- ♦ *The DPF warning lamp goes out after a successful regeneration of the particulate filter.*
- Then read fault memory of engine control unit and clear fault memory if necessary ⇒ [page 7](#), Clearing fault memory.

Renewing particulate filter

- Renew particulate filter ⇒ [page 266](#), Assembly overview - particulate filter.

If the particulate filter is renewed, the adaption of ash mass values must be set to "0" as follows:

- Switch on ignition.
- Select diagnosis function "014-Longer adaptation".
- Select "Adaption channel 16".
- Press key **Keypad**.
- Enter value 1 via screen keyboard.
- Press key.
- Press key **Confirm** to reset learnt values.
- Terminate diagnosis function.
- Switch ignition off and back on after 60 seconds.
- Select "display group 108" from "011-Read data block".

Indicated on display:

Display group 108			
110 ml	30.0 g	30.0 g	

- Check that the previously set adaption value for ash mass of "0" is displayed.
- Switch off ignition.



Setting engine control unit to previously read kilometre reading

Prerequisites

- Read kilometres since last regeneration ⇒ [page 283](#).
- Engine control unit has been renewed.

Procedure

If the engine control unit is renewed, the adaption of ash mass values must be set to the previously read values as follows:

- Switch on ignition.

Select diagnostic function “015-Access authorization”.

- Enter following access code.
- Access code: 12233
- Confirm access code.
- Press  key three times.
- Select diagnosis function “014-Longer adaptation”.
- Select “Adaption channel 15”.
- Set kilometres to previously read figures.
- Confirm and store this value.
- Terminate diagnosis function.
- Switch ignition off and back on after 60 seconds.
- Select “display group 108” from “011-Read data block”.

Indicated on display:

- Check saturation level of particulate filter.
- Select “display group 106” from “011-Read data block”.

Indicated on display:

- Check that the previously set kilometre figures since the last regeneration are displayed.
- Terminate diagnosis function.
- Adapt exhaust gas pressure sensor 1 -G450- ⇒ [page 260](#).

Display group 108			
110 ml	30.0 g	30.0 g	

Display group 106			
xxxx	xx l	xxxx km	xxxx



27 – Starter, voltage supply

1 Starter -B-

Observe safety precautions ⇒ page 208.

Observe rules for cleanliness ⇒ page 208.

Wiring connections on solenoid switch ⇒ page 288.

Starter -B- does not turn over ⇒ page 288.

Starter -B- turns over too slowly and does not turn engine over ⇒ page 289.

Removing and installing starter -B- ⇒ page 290.

1.1 Wiring connections on solenoid switch

- 1 - Terminal 30 - from battery -A-
- 2 - Terminal 50 - from ignition/starter switch -D-
- 3 - Connection for field windings

1.2 Starter -B- does not turn over

Special tools and workshop equipment required

- ◆ Adapter set -V.A.G 1594-
- ◆ Hand multimeter -V.A.G 1526- or multimeter -V.A.G 1715-
- ◆ Current flow diagram

Test prerequisites

- Fuses must be OK.
- Battery charged and checked.
- Earth connection OK.
- All electrical consumers must be switched off.
- Wiring connections on solenoid switch, earth strap between engine, assemblies and battery must be seated securely and not oxidized.

Test procedure

- Connect multimeter to measure voltage between terminal 50 -2- (with connector connected) and battery earth/engine earth.
- Operate ignition/starter switch and check voltage supply. Specification: At least 8.0 V.

If voltage is present at terminal 50 -2- on solenoid switch:

- Check voltage at connection for field windings -3- and battery earth/engine earth.
- Operate ignition/starter switch and check voltage. Specification: At least 8.0 V.

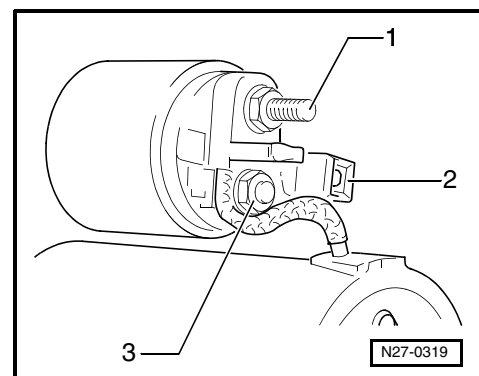
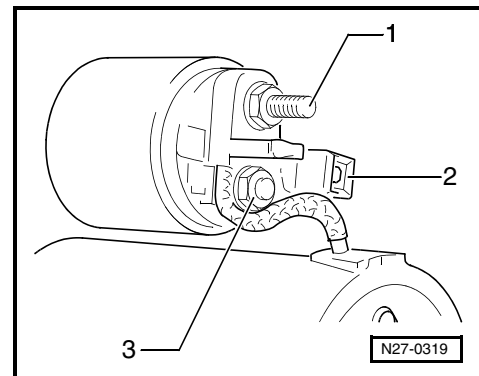



If specification is attained:

- Repair starter -B-.

If the specification is not attained:

- Renew solenoid switch.

If no voltage is present at terminal 50 -2- on solenoid switch:

- Check voltage at terminal 50 on ignition/starter switch and battery earth/engine earth referring to current flow diagram ⇒ [page 305](#), Current flow diagrams.
- Operate ignition/starter switch and check voltage. Specification: At least 8.0 V.

If the specification is not attained:

- Remove ignition/starter switch -D-.

If specification is attained:

- Check wiring between ignition/starter switch and starter for open circuit referring to current flow diagram. Wire resistance: max. 2.0 Ω

1.3 Starter -B- turns over too slowly and does not turn engine over

Test prerequisites

- Battery charged and checked.
- Poly V-belt tension and alternator security OK.
- All electrical consumers must be switched off.
- Wiring connections on solenoid switch, earth strap between engine, assemblies and battery must be seated securely and not oxidized.

Test procedure

- Operate ignition/starter switch.

Starter does not turn engine over:

- With ignition switched off, disconnect earth strap from battery.
- Clean connections on starter and earth strap between engine and assembly. Do not loosen earth strap on assembly when doing this.
- Tighten connections after cleaning.
- Reconnect earth strap to battery.
- Operate ignition/starter switch.

If the Starter still does not turn engine over, the following may be the cause of the fault:

- ◆ Insufficient contact between carbon brushes and commutator.
- Check carbon brushes for wear and renew if necessary.



- ◆ Commutator scored, burnt or soiled.
- Renew armature.

1.4 Removing and installing starter -B-

Special tools and workshop equipment required

- ◆ Torque wrench (5...50 Nm) -V.A.G 1331-
- ◆ Torque wrench (40...200 Nm) -V.A.G 1332-

Removing ⇒ [page 290](#).

Installing ⇒ [page 291](#).

Specified torques ⇒ [page 292](#).

1.4.1 Removing

Note

The following procedures contain basic notes for the removal and installation of the starter, more specific information is not possible due to the various configurations possible.

- Note safety precautions before beginning work
⇒ [page 208](#).
 - Observe rules for cleanliness ⇒ [page 208](#).
 - Disconnect battery, with ignition switched off.
 - Slide protective cap -in direction of arrow- off solenoid switch.
-
- Unscrew positive terminal 30 -1- and disconnect connector for terminal 50 -2-.

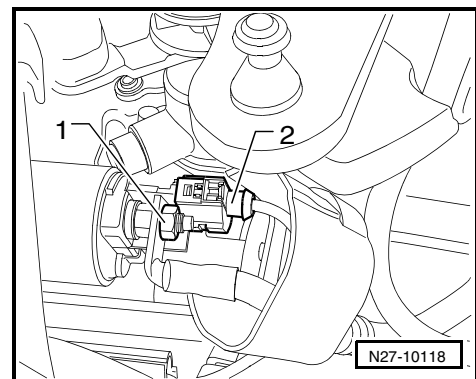
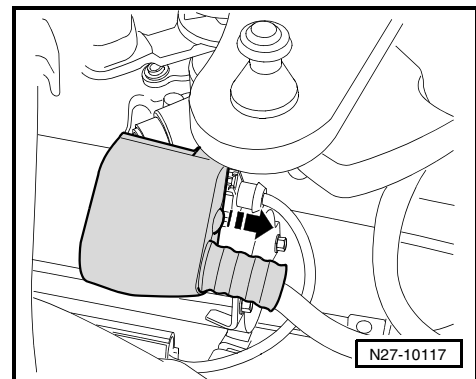
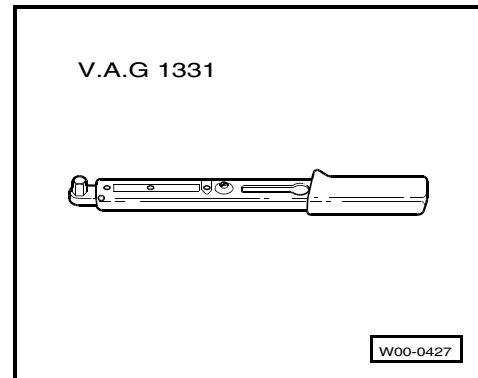

- Unscrew earth wire from starter securing bolt -arrow-.

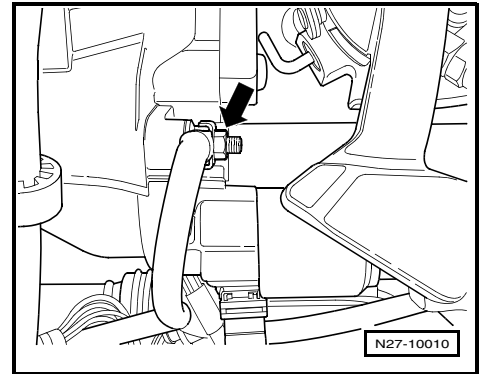

- Remove starter securing bolt -arrow-.

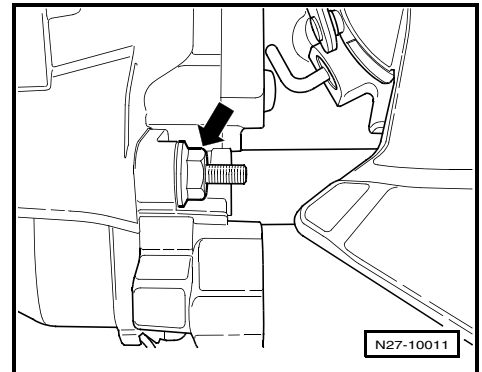

- Remove securing nut -1- from lower securing bolt for starter.
- Remove wiring retainer -2-.

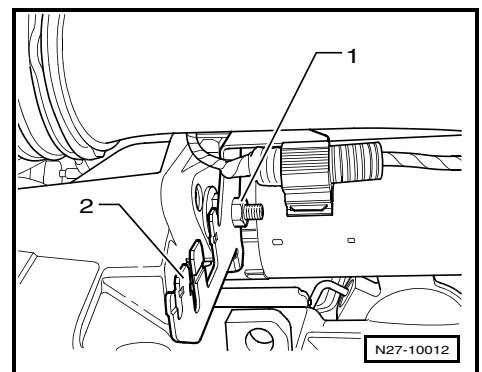

- Remove starter securing bolt -arrow-.
- Remove starter downwards.

1.4.2 Installing

Installation is carried out in the reverse sequence of removal. In the process, note the following:

- Tighten threaded connections to prescribed torque setting
⇒ [page 292](#).
- Reconnect battery, with ignition switched off.

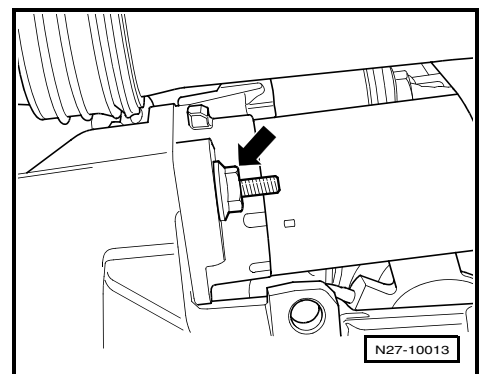



1.4.3 Specified torques

Threaded connection		Specified torque
Starter to assembly	M10	40 Nm
	M12	60 Nm
Earth wire on starter securing bolt	M8	15 Nm
Wiring retainer on starter securing bolt	M8	15 Nm
Positive wire on solenoid switch for starter	M8	15 Nm

2 Alternator -C-

Observe safety precautions ⇒ [page 208](#).

Observe rules for cleanliness ⇒ [page 208](#).

Assembly overview - alternator -C- ⇒ [page 292](#).

Tightening sequence and specified tightening torques for compact bracket to cylinder block ⇒ [page 78](#).

Checking alternator -C- and voltage regulator -C1- ⇒ [page 294](#).

Removing and installing alternator -C- ⇒ [page 295](#).

Removing and installing voltage regulator -C1- ⇒ [page 297](#).

Removing and installing poly V-belt pulley ⇒ [page 300](#).

Checking function of free-wheel coupling ⇒ [page 304](#).

2.1 Assembly overview - alternator -C-



Note

Removing and installing bracket for ancillary units ⇒ [page 78](#).



1 - Hexagon bolt with washer and threaded element, 2 Nm

- M4 x 20.
- M4 x 15.

2 - Protective cap

- For alternator.

3 - Cross-head screw, 2 Nm

- M4 x 20.

4 - Protective cap

- For carbon brushes.

5 - Voltage regulator -C1-

- Checking
⇒ [page 294](#) alternator -C- and voltage regulator -C1-.
- Removing and installing
⇒ [page 297](#).

6 - Alternator -C-

- Securing "B+ wire" to alternator ⇒ [Fig. on page 294](#).
- Checking
⇒ [page 294](#) alternator -C- and voltage regulator -C1-.
- Removing and installing
⇒ [page 295](#).
- Removing and installing poly V-belt pulley ⇒ [page 300](#).
- Checking function of free-wheel coupling ⇒ [page 304](#).

7 - Poly V-belt

- Mark direction of rotation before removing.
- Do not kink.
- Removing and installing ⇒ [page 76](#).
- Checking for wear ⇒ [page 77](#).

8 - Hexagon head collar bolt 20 Nm

- M8 x 90.
- Tightening sequence and specified tightening torques for compact bracket to cylinder block
⇒ [page 78](#).

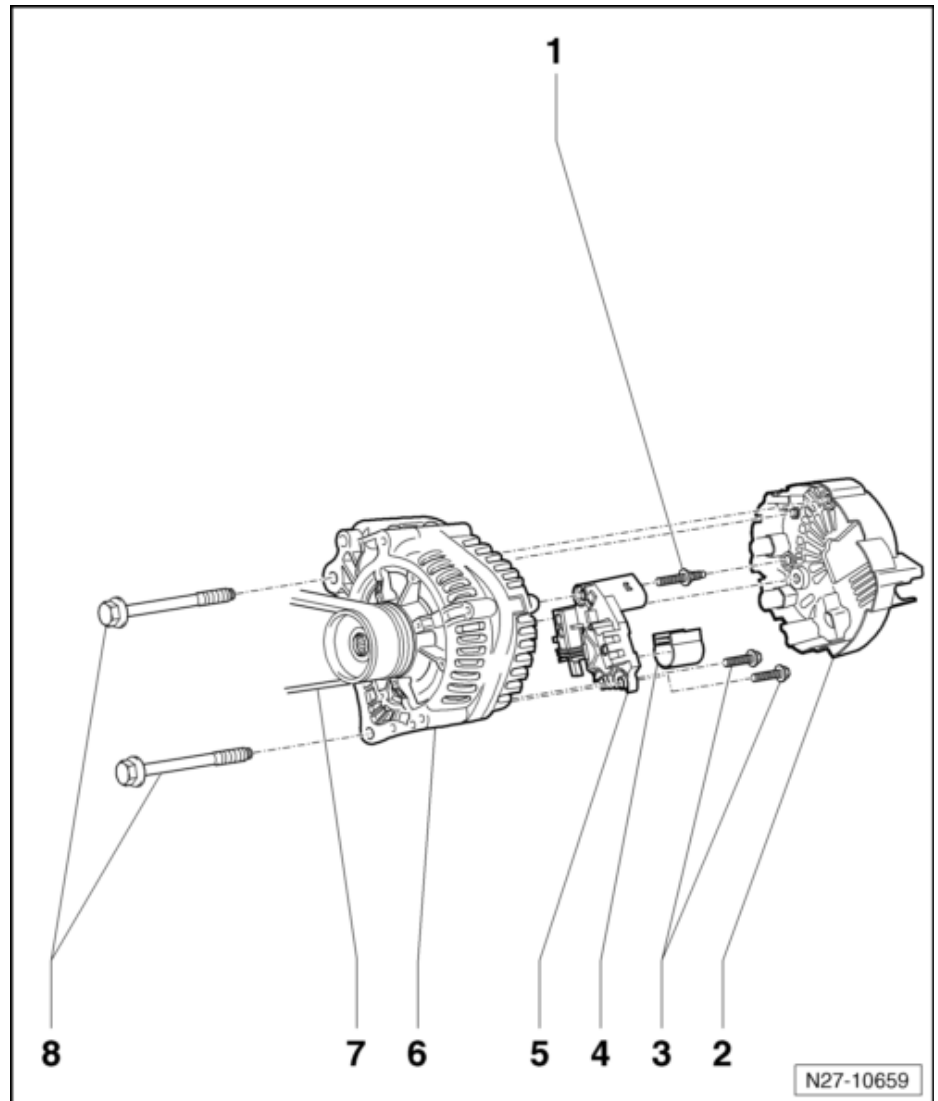



Securing "B+ wire" to alternator

Special tools and workshop equipment required

- ◆ Torque wrench (5...50 Nm) -V.A.G 1331-

Note

The threaded connection for the + wire on the alternator is designated "B1 + "!

Caution!

If the B+ (battery positive) cable is not tightened to the specified torque setting, there is a risk of the following:

- ◆ The battery will not be charged fully.
 - ◆ Electrics/electronics fail completely.
 - ◆ Danger of fires from sparks.
 - ◆ Damage to electronic components and control units due to excessive voltage.
- With ignition switched off, disconnect earth strap from battery.
 - Tighten securing nut for "B1 + wire" -arrow-. Specified torque: 15 Nm.

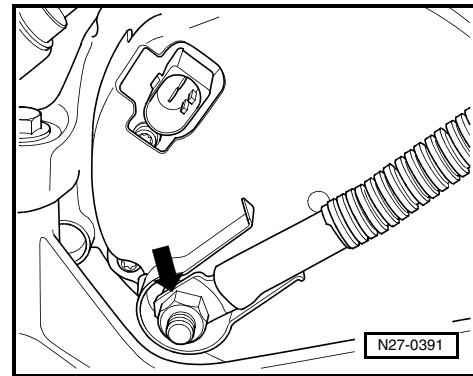

2.2 Checking alternator -C- and voltage regulator -C1-

Special tools and workshop equipment required

- ◆ Multimeter -V.A.G 1715-
- ◆ Adapter set -V.A.G 1594 C-

Test prerequisites

- Fuses must be OK.
- Battery charged and checked.
- Earth connection OK.
- Poly V-belt tension and alternator security OK.
- No faults must be stored in fault memory ⇒ [page 7](#), Reading fault memory.

Test procedure

- Unscrew securing nuts -arrows A- and remove securing bolt -arrow B- for protective cap and remove protective cap.
- Switch on multimeter -V.A.G 1715-.
- Connect black earth wire (-) to battery earth strap.
- Connect red positive wire (+) to "terminal D+" on alternator.
- Switch off all electrical consumers.

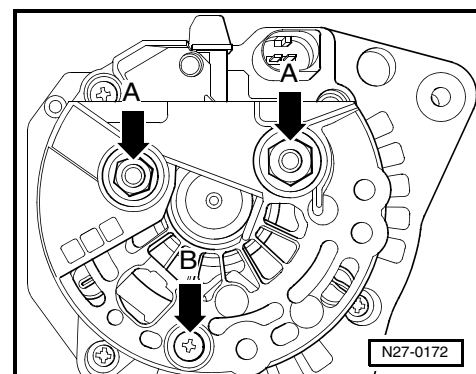
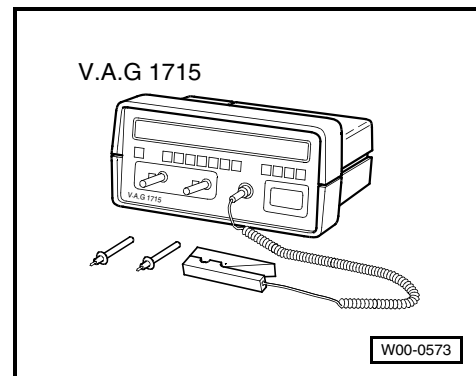



- Start engine and allow it to run at 1500...2000 for several seconds.

If the multimeter -V.A.G 1715- displays "not OK.":

- For test purposes, renew voltage regulator -C1-
⇒ [page 297](#), Removing and installing voltage regulator -C1-.
- Repeat test sequence.

If the multimeter -V.A.G 1715- displays "not OK." again:

- Renew alternator -C- ⇒ [page 295](#), Removing and installing alternator -C-.

2.3 Removing and installing alternator -C-

Special tools and workshop equipment required

- ◆ Torque wrench (5...50 Nm) -V.A.G 1331-

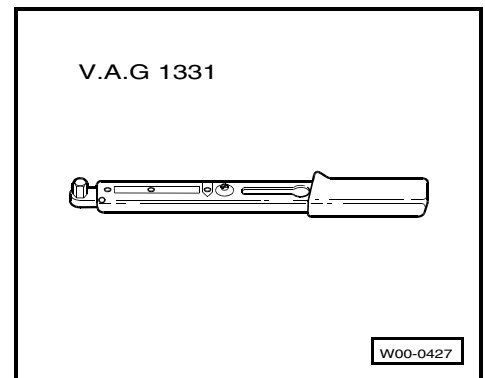

- ◆ Locking pin -T10060 A-

Removing ⇒ [page 295](#).

Installing ⇒ [page 297](#).

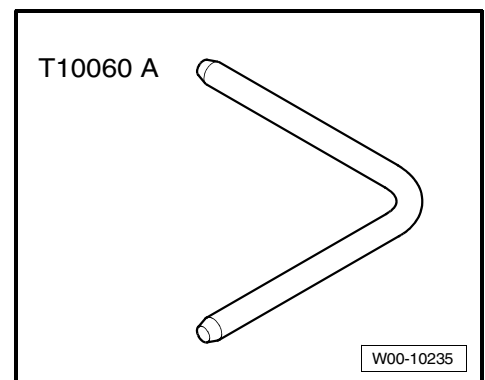

2.3.1 Removing

Note

The following procedures contain basic notes for the removal and installation of the alternator, more specific information is not possible due to the various configurations possible.

- Note safety precautions before beginning work
⇒ [page 208](#).
- Observe rules for cleanliness ⇒ [page 208](#).
- Remove poly V-belt ⇒ [page 76](#).
- Disconnect battery, with ignition switched off.



- Pull connector -1- off air conditioner compressor (when installed).

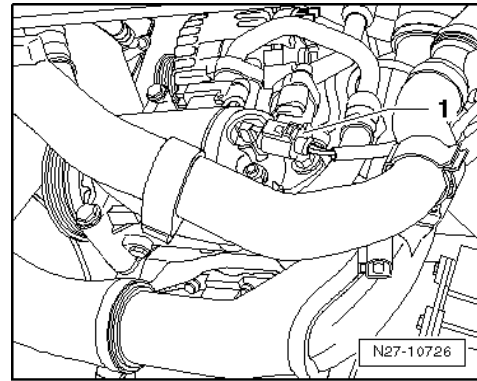

- Unscrew securing bolts of air conditioner compressor -arrows- (when installed).
- Suspend the air conditioner compressor using a piece of binding wire at a suitable position.

i Note

- ♦ *The hoses of the air conditioner compressor can remain connected.*
- ♦ *Ensure that the hoses are not stretched or kinked when doing this.*

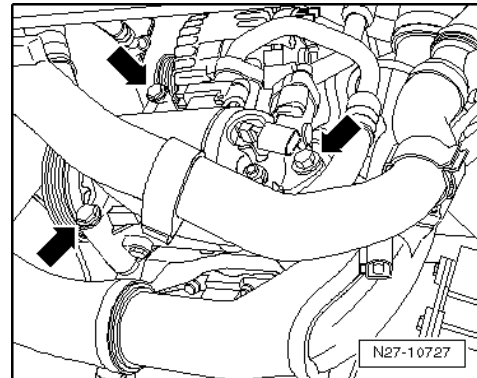

- Separate DF wire connector -1- and pull off protective cap -2-.

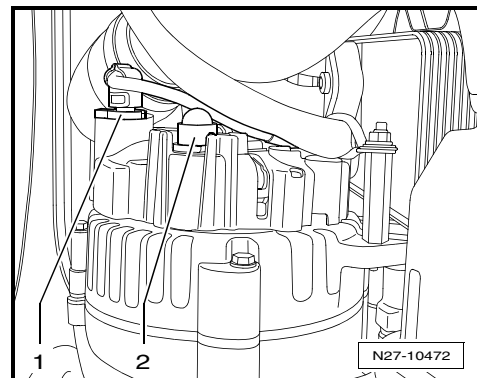

- Unscrew securing nut -1- and remove “B+ wire”, located beneath, from connector thread of alternator.
- Unscrew securing nut -3- and remove wiring retainer -2- from alternator.
- If necessary, remove fuel filter and place to one side. When doing this, the fuel hoses can remain connected
⇒ [page 173](#), Assembly overview - fuel filter.

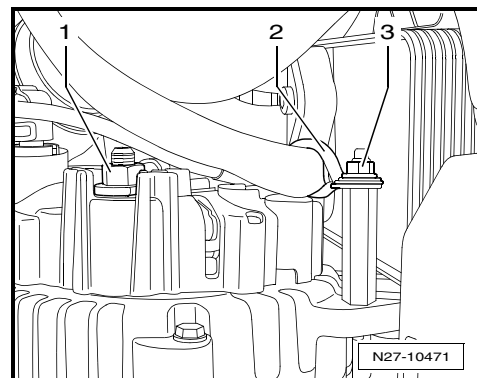



- Unscrew alternator securing bolts -arrows-.
- Remove alternator.

2.3.2 Installing

Installation is carried out in the reverse sequence of removal. In the process, note the following:

- In order to avoid damage to cylinder block and compact bracket, adhere strictly to the tightening sequence and specified tightening torques for the compact bracket ⇒ [page 78](#).
- Drive threaded sleeves -A- roughly 4 mm in -direction of arrow- out of alternator housing.

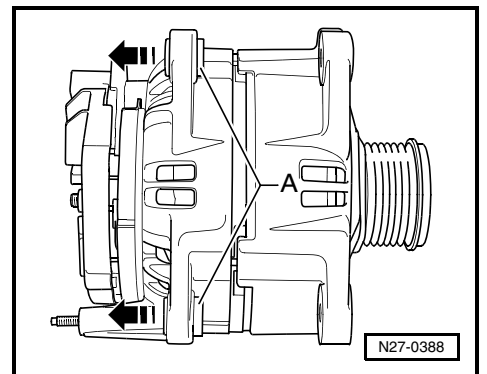
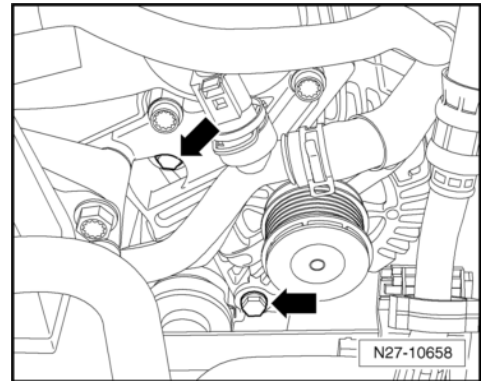

- Fit cable retainer -arrow- on back of alternator in 3 o'clock position and secure.
- Tighten threaded connections to torques specified in assembly overview ⇒ [page 292](#).
- Reconnect battery, with ignition switched off.
- Install poly V-belt ⇒ [page 76](#).

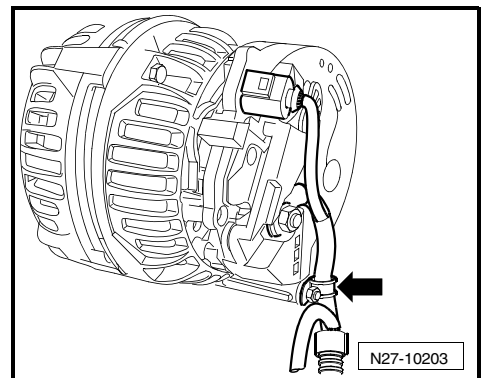

2.4 Removing and installing voltage regulator -C1-

Removing and installing voltage regulator -C1-:

- ◆ Manufacturer: Bosch ⇒ [page 297](#),
- ◆ Manufacturer: Valeo ⇒ [page 299](#).

2.4.1 Removing and installing voltage regulator -C1- (manufacturer: Bosch)

Special tools and workshop equipment required

- ◆ Torque screwdriver (1...5 Nm) -V.A.G 1624-

Removing ⇒ [page 297](#).

Installing ⇒ [page 298](#).

Removing

- Remove alternator -C- ⇒ [page 295](#).

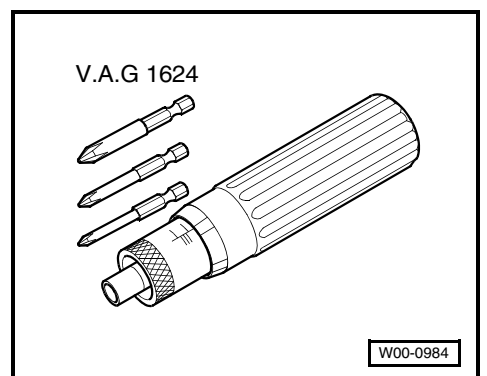



- Unscrew securing nuts -arrows A- and securing bolt -arrow B- for protective cap and remove protective cap.

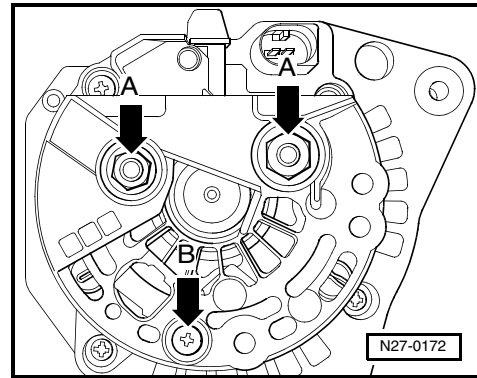

- Unscrew voltage regulator securing screws -arrows- and remove voltage regulator.

Installing

Installation is carried out in the reverse sequence of removal. In the process, note the following:

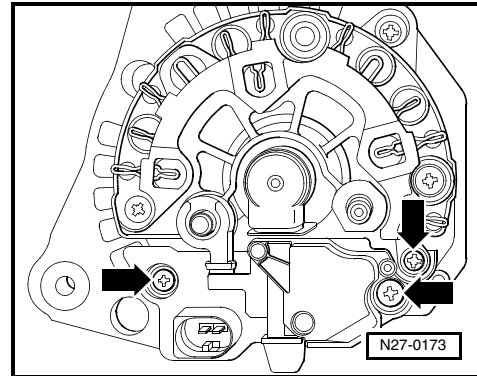

- Tighten voltage regulator securing screws -arrows- on alternator to 2 Nm.

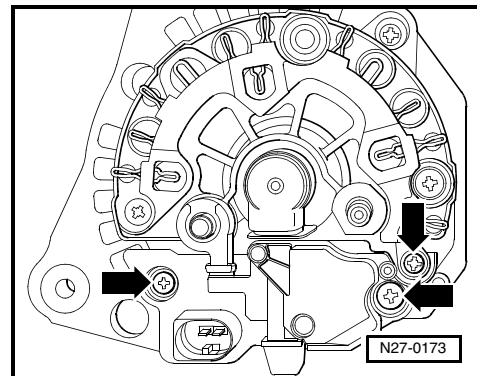

- Install protective cap and securing nuts -arrows A- and securing bolt -arrow B- and tighten to 25 Nm.
- Install alternator -C- → [page 295](#).

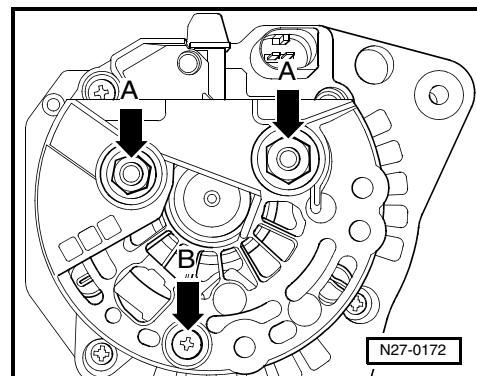



2.4.2 Removing and installing voltage regulator -C1- (manufacturer: Valeo)

Special tools and workshop equipment required

- ◆ Torque wrench (2...10 Nm) -V.A.G 1783-

Removing ⇒ [page 299](#).

Installing ⇒ [page 299](#).

Removing

- Remove alternator -C- ⇒ [page 295](#).

- Remove clamping rings -arrows- and detach protective cap from alternator.

- Unscrew voltage regulator securing screws and securing nut -arrows- and remove voltage regulator.

Installing

Installation is carried out in the reverse sequence of removal. In the process, note the following:

- Release locking lugs -arrows- and pull protective cap off voltage regulator.
- Press carbon brushes into housing of voltage regulator and insert voltage regulator in alternator.

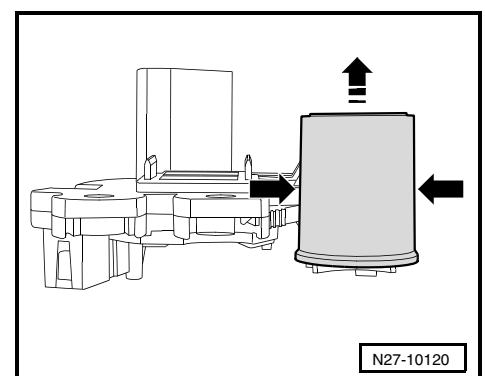
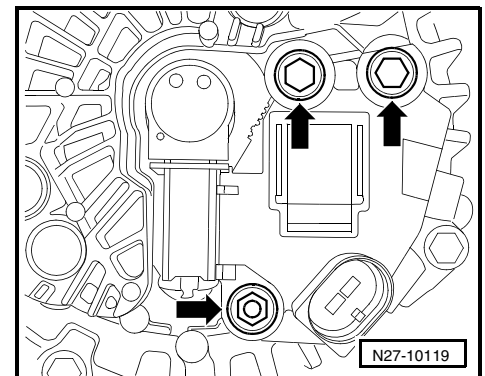
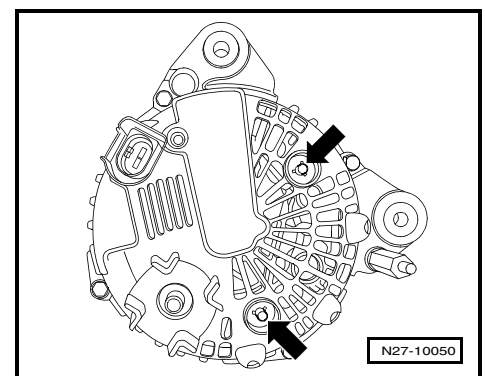
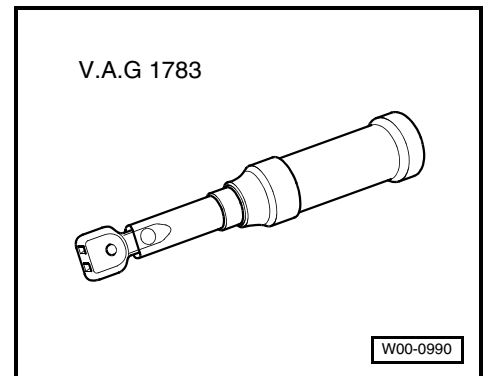



- Tighten voltage regulator securing screws and securing nut -arrows- on alternator to 2 Nm.

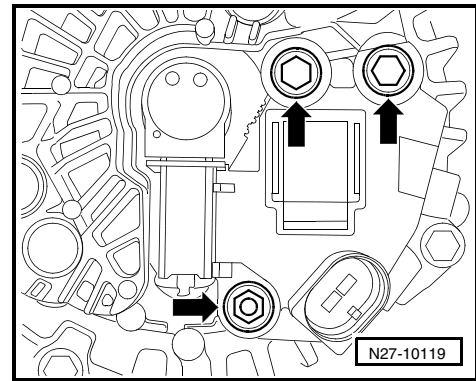

- Push protective cap in guides -arrows- until it can be heard to engage.
- Install alternator -C- ⇒ [page 295](#).

2.5 Removing and installing poly V-belt pulley .

Removing and installing poly V-belt pulley.

- ◆ No freewheel ⇒ [page 300](#),
- ◆ With freewheel (manufacturer: Bosch) ⇒ [page 301](#),
- ◆ With freewheel (manufacturer: Valeo) ⇒ [page 303](#).

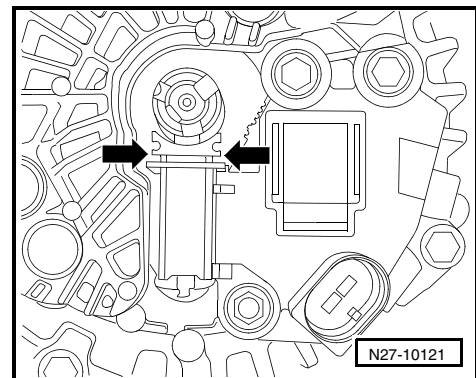

2.5.1 Removing and installing poly V-belt pulley with no freewheel

Special tools and workshop equipment required

- ◆ Torque wrench (40...200 Nm) -V.A.G 1332-

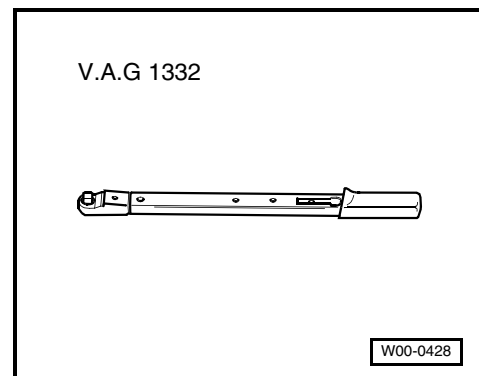

- ◆ Allen key, long reach -3310-

Removing ⇒ [page 300](#).

Installing ⇒ [page 301](#).

Removing

- Remove alternator -C- ⇒ [page 295](#).
- Clamp alternator in vice at mounting points.

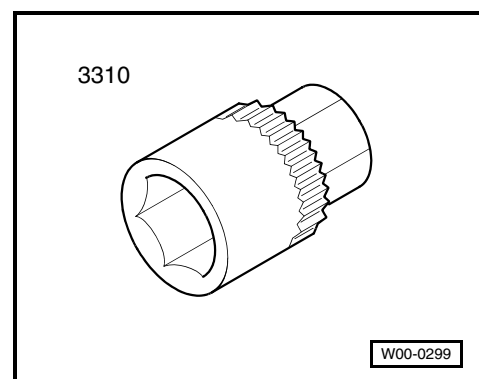



- Use socket -VAS 3310- to unscrew poly-V-belt pulley securing nut from alternator shaft.

Installing

Installation is carried out in the reverse order. When installing, note the following:

- Tighten poly V-belt pulley securing nut on alternator shaft to 65 Nm.
- Install alternator -C- ⇒ [page 295](#).

2.5.2 Removing and installing poly V-belt pulley with freewheel (manufacturer: Bosch)

Special tools and workshop equipment required

- ♦ Torque wrench (40...200 Nm) -V.A.G 1332-

- ♦ Adapter -3400-

Removing ⇒ [page 301](#).

Installing ⇒ [page 302](#).

Removing

- Remove alternator -C- ⇒ [page 295](#).
- Clamp alternator in vice at mounting points.
- Remove protective cap from poly V-belt pulley with freewheel.
- Insert adapter -3400- with 17 mm ring spanner in alternator poly V-belt pulley with freewheel.

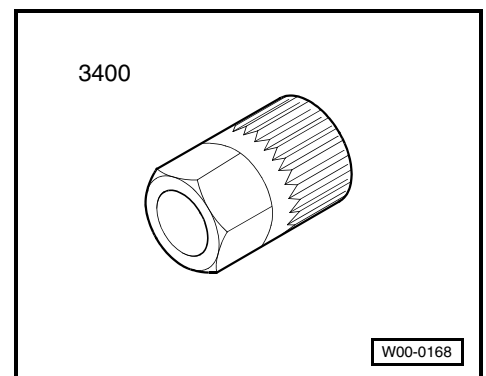
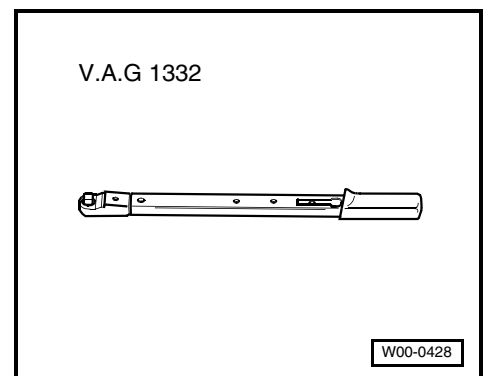
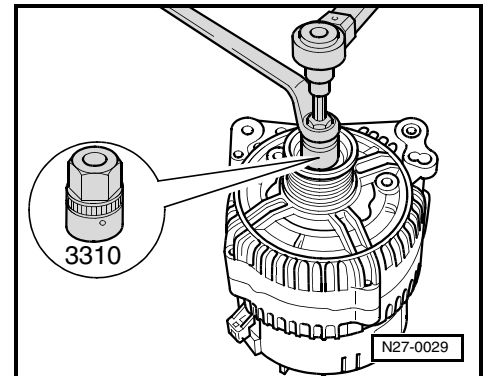
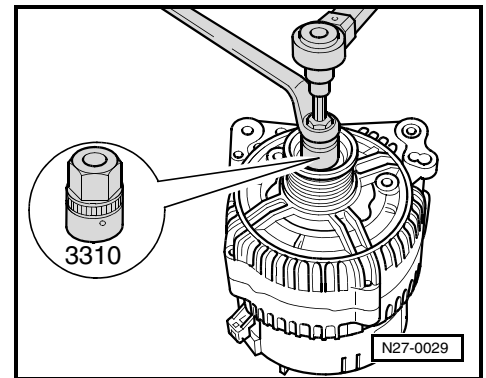



- Insert a M10 multi-point bit -1- into alternator shaft.
- Loosen threaded connection by turning clockwise. Counterhold with ring spanner when doing this.
- Hold poly V-belt pulley with freewheel by hand. Turn drive shaft of alternator until poly V-belt pulley with freewheel can be removed.

Installing

Installation is carried out in the reverse order. When installing, note the following:

- First screw poly V-belt pulley with freewheel on drive shaft of alternator by hand as far as limit stop.

The torque wrench must be modified for assembly of poly V-belt with freewheel as follows:

- Release connector -1- and pull it off grip -2-.
- Turn grip -2- of torque wrench through 180 degrees and reinsert socket drive.
- Set turning direction of torque wrench to anti-clockwise on socket drive.

- Insert a M10 multi-point bit -1- into alternator shaft.
- Counterhold using adapter -3400- and 17 mm ring spanner.
- Tighten poly V-belt pulley with freewheel by turning alternator drive shaft anti-clockwise using torque wrench -V.A.G 1332-.
- Tighten poly V-belt pulley threaded connection on alternator shaft to 80 Nm.
- Install alternator -C- ⇒ [page 295](#).

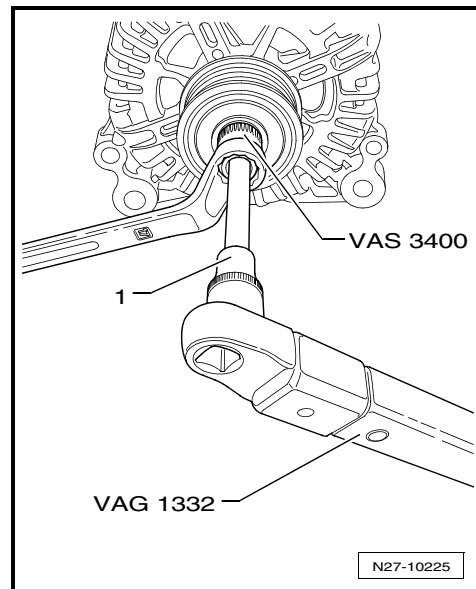
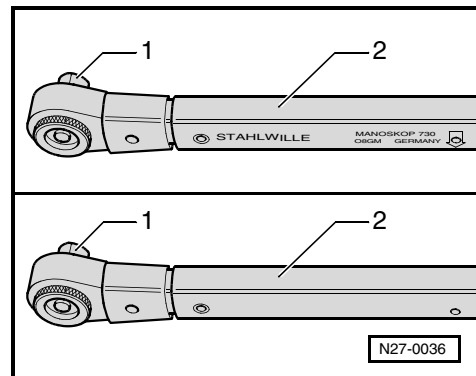
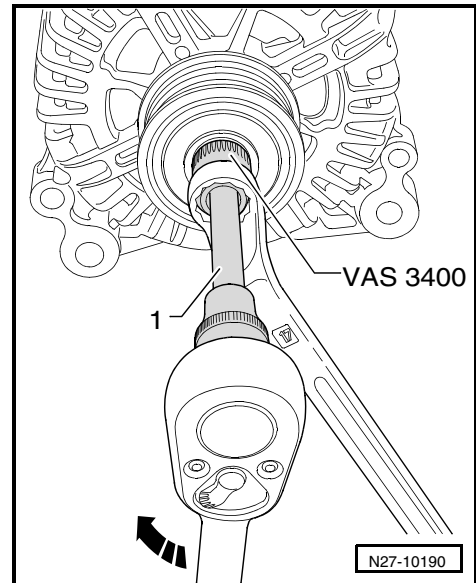





2.5.3 Removing and installing poly V-belt pulley with freewheel (manufacturer: Valeo)

Special tools and workshop equipment required

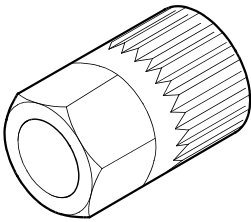
- ◆ Adapter -3400-
- ◆ Torque wrench (40...200 Nm)
-V.A.G 1332-
- ◆ TORX driver bit
-V.A.G 1603/1-

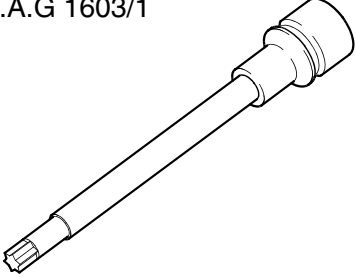
3400 	V.A.G 1332 
V.A.G 1603/1 	
	W27-10006

Removing ⇒ [page 303](#).

Installing ⇒ [page 304](#).

Removing

- Remove alternator -C- ⇒ [page 295](#).
- Clamp alternator in vice at mounting points.
- Remove protective cap from poly V-belt pulley with freewheel.
- Insert adapter -3400- with 17 mm ring spanner in alternator poly V-belt pulley with freewheel.



- Insert TORX driver bit -V.A.G 1603/1- in alternator shaft.
- Loosen threaded connection by turning clockwise. Counterhold with ring spanner when doing this.
- Hold poly V-belt pulley with freewheel by hand. Turn drive shaft of alternator until poly V-belt pulley with freewheel can be removed.

Installing

Installation is carried out in the reverse order. When installing, note the following:

- First screw poly V-belt pulley with freewheel on drive shaft of alternator by hand as far as limit stop.

The torque wrench must be modified for assembly of poly V-belt with freewheel as follows:

- Release connector -1- and pull it off grip -2-.
- Turn grip -2- of torque wrench through 180 degrees and reinsert socket drive.
- Set turning direction of torque wrench to anti-clockwise on socket drive.

- Insert TORX driver bit -V.A.G 1603/1- in alternator shaft.
- Counterhold using adapter -3400- and 17 mm ring spanner.
- Tighten poly V-belt pulley with freewheel by turning alternator drive shaft anti-clockwise using torque wrench -V.A.G 1332-.
- Tighten poly V-belt pulley threaded connection on alternator shaft to 80 Nm.
- Install alternator -C- ⇒ [page 295](#).

2.6 Checking function of free-wheel coupling



Note

On alternators 05.99 ► the belt pulley with freewheel is the same on all alternators used (different manufacturers).

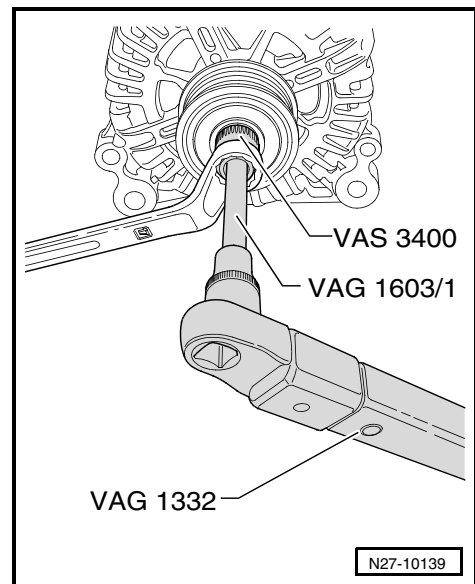
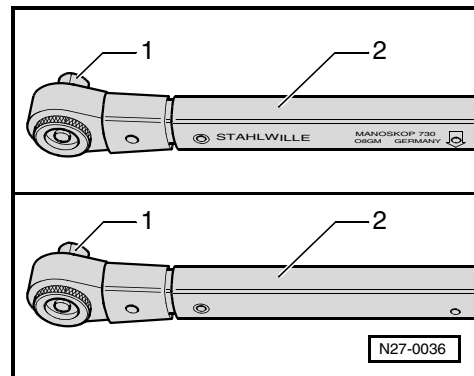
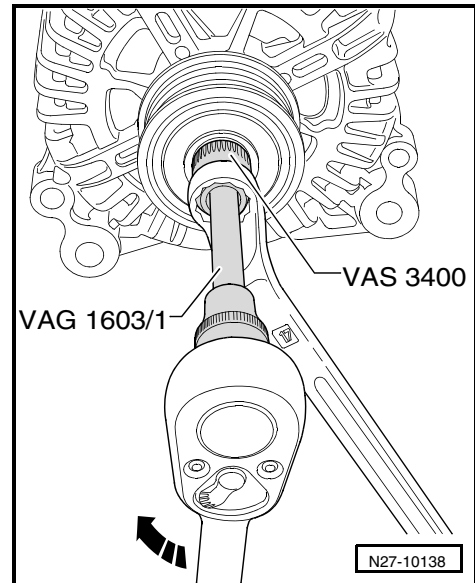



Special tools and workshop equipment required

- ◆ Adapter -3400-

Test prerequisite

- Poly V-belt tension and alternator security OK.

Test procedure

- Remove protective cap from poly V-belt pulley with freewheel.
- Insert adapter -3400- in alternator poly V-belt pulley with freewheel.
- Turn drive shaft of alternator with poly V-belt pulley using a 17 mm ring spanner on adapter -3400- anticlockwise.

If the only the drive shaft in the poly V-belt pulley turns, running surface of belt pulley remains in position:

- Renew poly V-belt pulley with freewheel coupling
⇒ [page 300](#), Removing and installing poly V-belt pulley.

If the running surface of belt pulley together with the drive shaft in the poly V-belt pulley:

- Clip protective cap onto poly V-belt pulley with freewheel.
- Check alternator -C- and voltage regulator -C1-
⇒ [page 294](#).

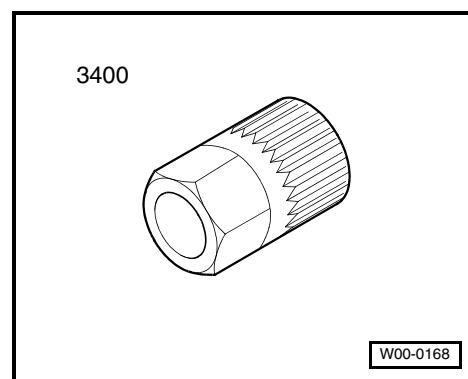

3 Current flow diagrams

Note

- ◆ Due to the various installation applications for industrial engines, the following current flow diagrams can only show examples of circuits.
- ◆ Cross section details are minimum sizes. Larger cross sections are dependant on component and must be observed during repairs.



WARNING!

Before working on electrical system disconnect battery earth strap.

Observe safety precautions ⇒ [page 208](#).

Observe rules for cleanliness ⇒ [page 208](#).

Current flow diagrams:

- ◆ Vehicles with emission standard (97/68) ⇒ [page 306](#).
- ◆ Vehicles with emission standard (EU 5) and engine code CJDA ⇒ [page 320](#).



3.1 Current flow diagrams: Emission standard (97/68)

Battery, starter, alternator, voltage regulator, ignition/starter switch ⇒ [page 307](#).

Electric fuel pump 2 relay, automatic glow period control unit, glow plugs, fuses, supplementary fuel pump ⇒ [page 308](#).

Terminal 30 voltage supply relay, engine control unit, fuses ⇒ [page 309](#).

Coding bridges, charge air pressure sender, intake air temperature sender, air mass meter, engine control unit ⇒ [page 310](#).

Accelerator position sender, accelerator position sender 2, engine control unit, injectors for cylinders 1...4 ⇒ [page 311](#).

Hall sender, coolant temperature sender, engine control unit, fuel pressure regulating valve, fuel metering valve ⇒ [page 312](#).

Engine speed sender, throttle valve potentiometer, fuel temperature sender, position sender for charge pressure positioner, throttle valve module, engine control unit ⇒ [page 313](#).

Exhaust gas recirculation potentiometer, exhaust gas temperature sender 1, fuel pressure sender, engine control unit, exhaust gas recirculation valve ⇒ [page 314](#).

Brake light switch, brake pedal switch, engine control unit, charge pressure control solenoid valve, crankcase breather heater element ⇒ [page 315](#).

Working speed control switch, working speed control, resume button, preset revolutions 1 and 2 switch, clutch pedal switch, engine control unit ⇒ [page 316](#).

Preset revolution 3 switch, engine control unit, alternator warning lamp, glow period warning lamp, exhaust emissions warning lamp ⇒ [page 317](#).

Working speed control, safety contact switch, working speed control, decrease speed button, working speed control, increase speed button, working speed control switch 2, engine control unit, working speed control warning lamp ⇒ [page 318](#).

Coding bridges, radiator fan relay, engine control unit, radiator fan single fuse, radiator fan ⇒ [page 336](#).

Diagnosis connection, oil pressure switch, engine control unit, oil pressure warning lamp ⇒ [page 320](#).



3.1.1 Battery, starter, alternator, voltage regulator, ignition/starter switch fuses

- A - Battery**
- B - Starter**
- C - Alternator**
- C1 - Voltage regulator**
- D - Ignition/starter switch**
- S5 - Fuse**
 - 15 A
 - In fuse holder.
- S8 - Fuse**
 - 5 A
 - In fuse holder.
- S10 - Fuse**
 - 5 A
 - In fuse holder.
- B-M - Battery earth/engine earth**

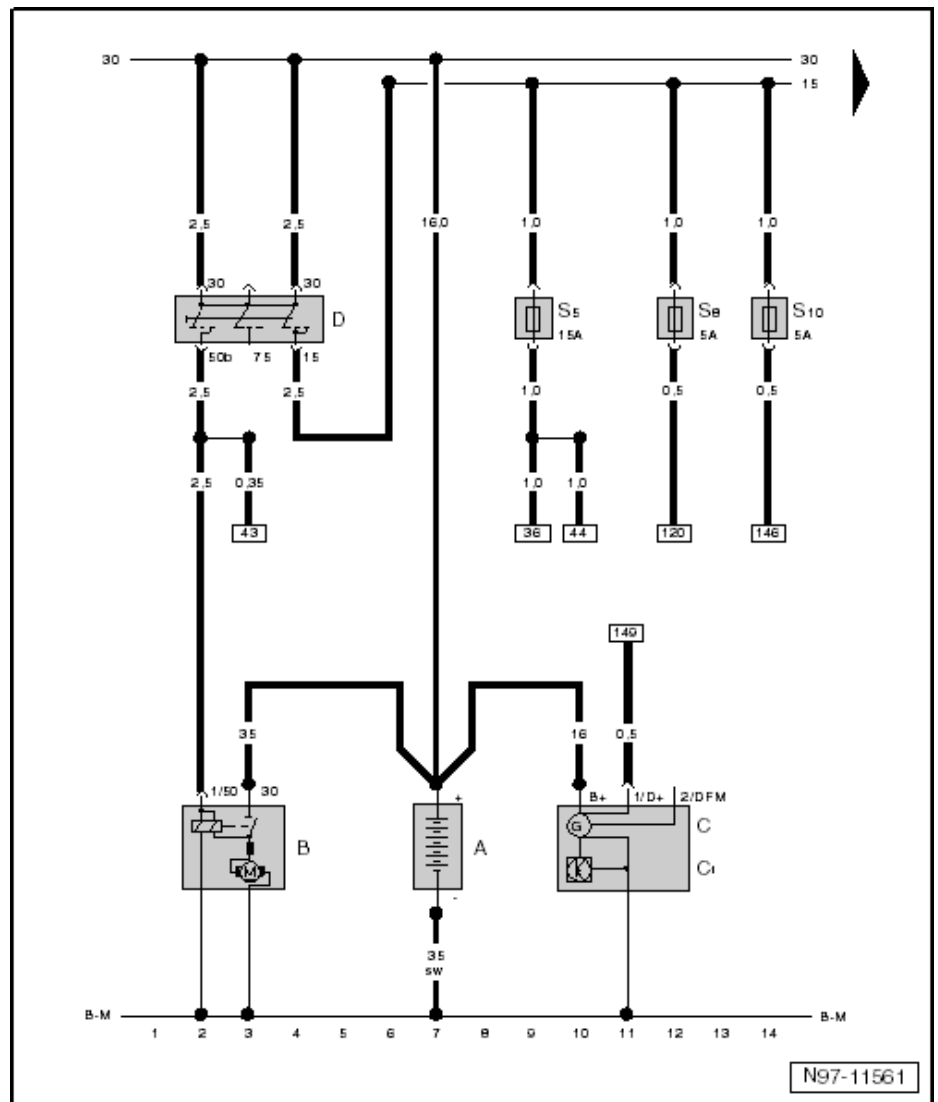

N97-11561



3.1.2 Electric fuel pump 2 relay, automatic glow period control unit, glow plugs, fuses, supplementary fuel pump

J49-Electric fuel pump 2 relay

J179-Automatic glow period control unit

Q10-Glow plug 1

Q11-Glow plug 2

Q12-Glow plug 3

Q13-Glow plug 4

S1- Fuse

□ 20 A

□ In fuse holder.

S3- Fuse

□ 50 A

□ In fuse holder.

T4a-4-pin connector

T11-11-pin connector

T14-14-pin connector

V393-Supplementary fuel pump

B-M-Battery earth/engine earth

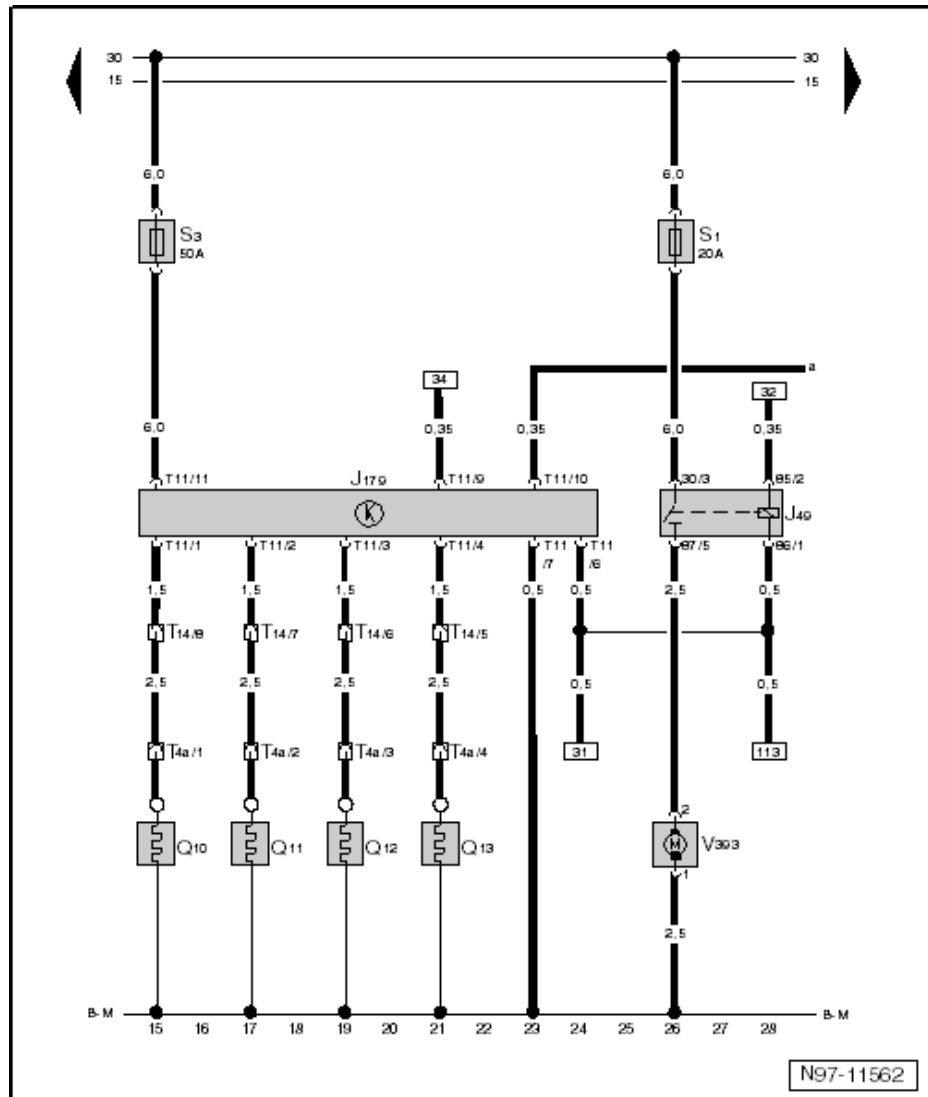



3.1.3 Terminal 30 voltage supply relay, engine control unit, fuses

J317-Terminal 30 voltage supply relay

J623-Engine control unit

S2 - Fuse

- 20 A
- In fuse holder.

S4 - Fuse

- 15 A
- In fuse holder.

S6 - Fuse

- 5 A
- In fuse holder.

S7 - Fuse

- 30 A
- In fuse holder.

S9 - Fuse

- 5 A
- In fuse holder.

T14-14-pin connector

T60-60-pin connector

T94-94-pin connector

131-Earth connection 2, in engine compartment wiring harness

D180-Connection (87a), in engine compartment wiring harness

D182-Connection 3 (87a), in engine compartment wiring harness

B-M-Battery earth/engine earth

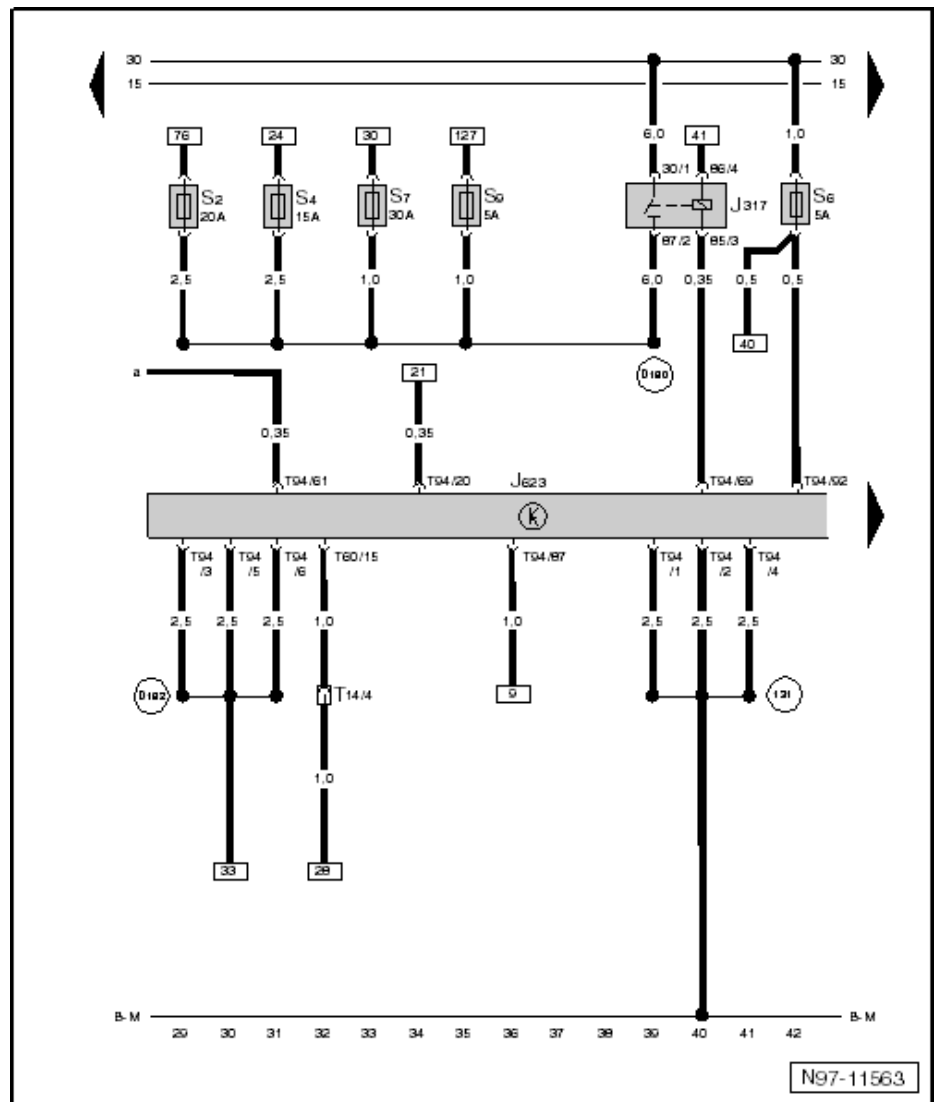



3.1.4 Coding bridges, charge air pressure sender, intake air temperature sender, air mass meter, engine control unit

- G31-Charge air pressure sender
- G42-Intake air temperature sender
- G70-Air mass meter
- J623-Engine control unit
- T5- 5-pin connector
- T94-94-pin connector
- B-M-Battery earth/engine earth

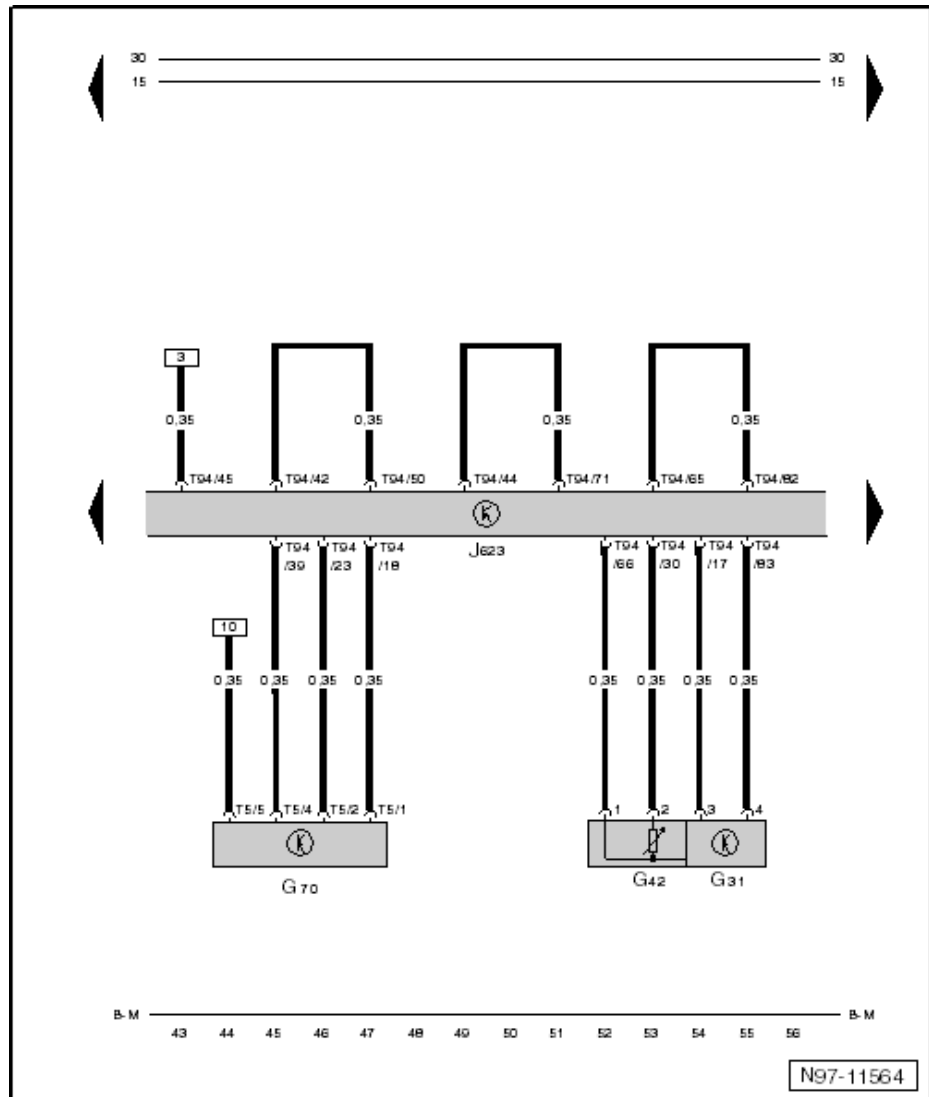



3.1.5 Accelerator position sender, accelerator position sender 2, engine control unit, injectors for cylinders 1...4

- G79-Accelerator position sender
- G185-Accelerator position sender 2
- J623-Engine control unit
- N30-Injector, cylinder 1
- N31-Injector, cylinder 2
- N32-Injector, cylinder 3
- N33-Injector, cylinder 4
- T6a-6-pin connector
- T60-60-pin connector
- T94-94-pin connector
- B-M-Battery earth/engine earth

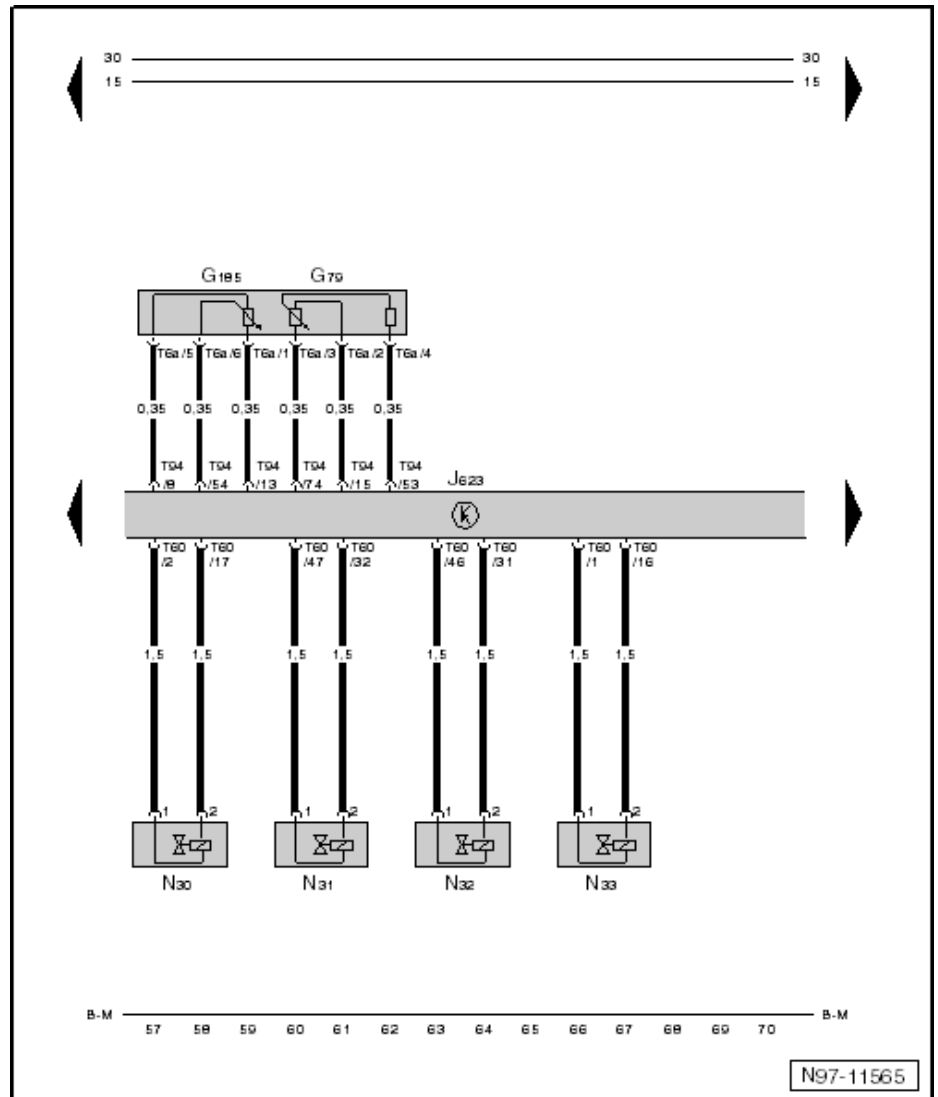

N97-11565



3.1.6 Hall sender, coolant temperature sender, engine control unit, fuel pressure regulating valve, fuel metering valve

- G40-Hall sender
- G62-Coolant temperature sender
- J623-Engine control unit
- N276-Fuel pressure regulating valve
- N290-Fuel metering valve
- T3 - 3-pin connector
- T14-14-pin connector
- T60-60-pin connector
- B-M-Battery earth/engine earth

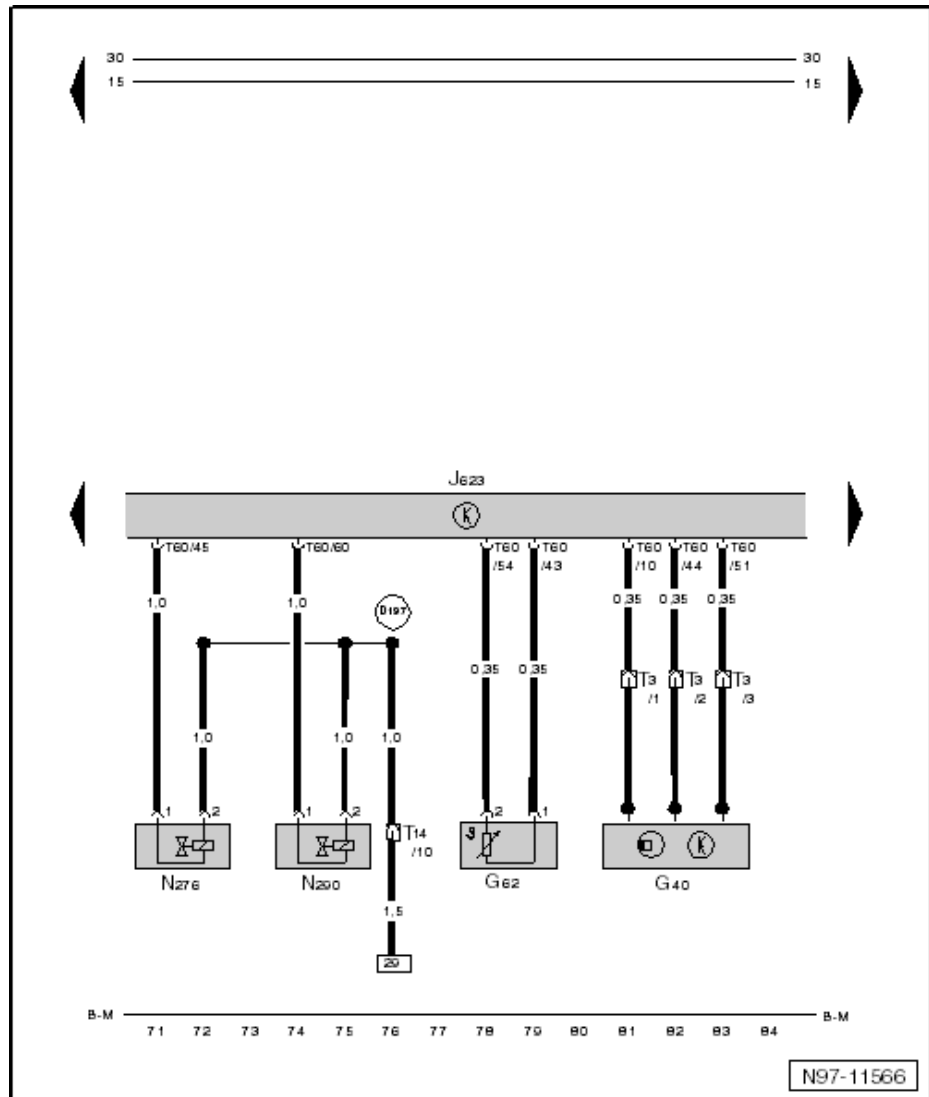



3.1.7 Engine speed sender, throttle valve potentiometer, fuel temperature sender, position sender for charge pressure positioner, throttle valve module, engine control unit

- G28-Engine speed sender
- G69-Throttle valve potentiometer
- G81-Fuel temperature sender
- G581-Position sender for charge pressure positioner
- J338-Throttle valve module
- J623-Engine control unit
- T60-60-pin connector
- 220-Earth connection (sender earth), in engine wiring harness
- D101-Connection 1, in engine compartment wiring harness
- B-M-Battery earth/engine earth

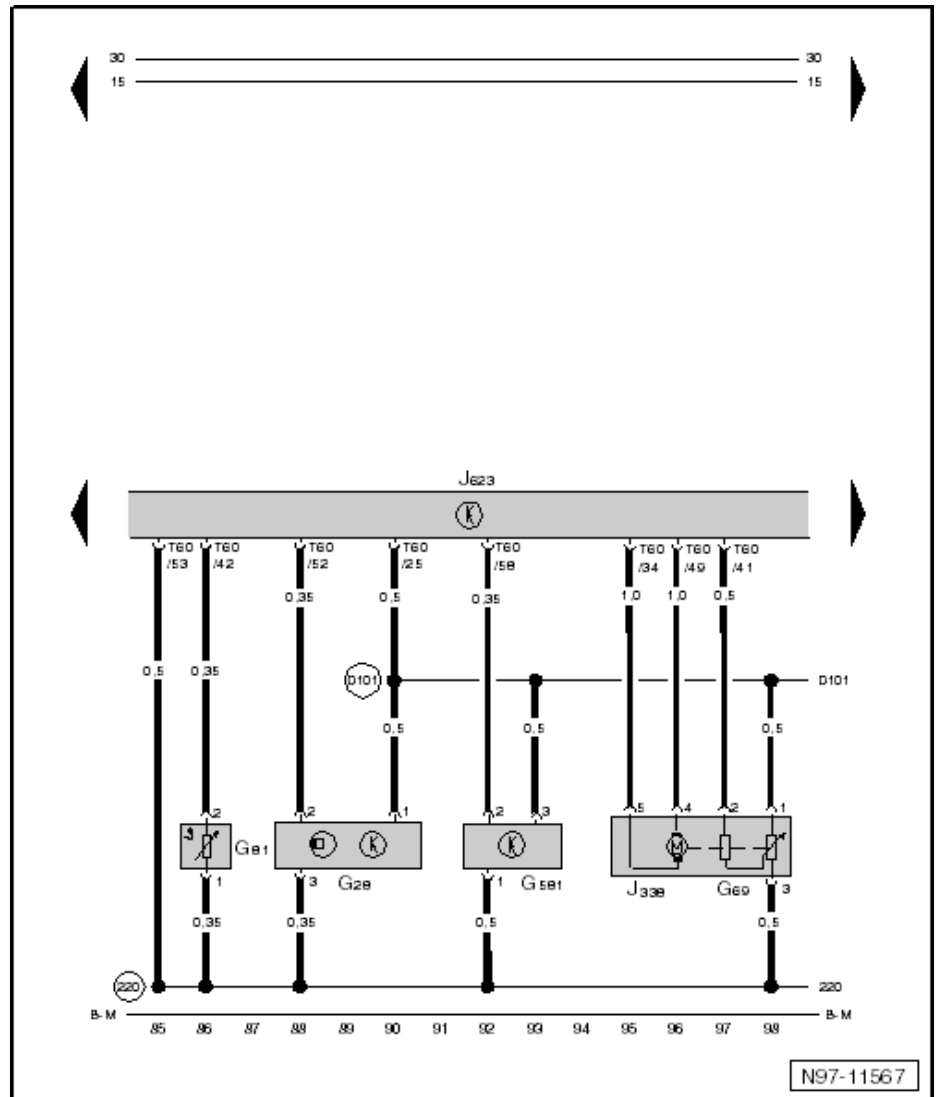



3.1.8 Exhaust gas recirculation potentiometer, exhaust gas temperature sender 1, fuel pressure sender, engine control unit, exhaust gas recirculation valve

G212-Potentiometer for exhaust gas recirculation

G235-Exhaust gas temperature sender 1

G247-Fuel pressure sender

J623-Engine control unit

N18-Exhaust gas recirculation valve

T2a- 2-pin connector

T6- 6-pin connector

T60-60-pin connector

T94-94-pin connector

220-Earth connection (sender earth), in engine wiring harness

D101-Connection 1, in engine compartment wiring harness

B-M-Battery earth/engine earth

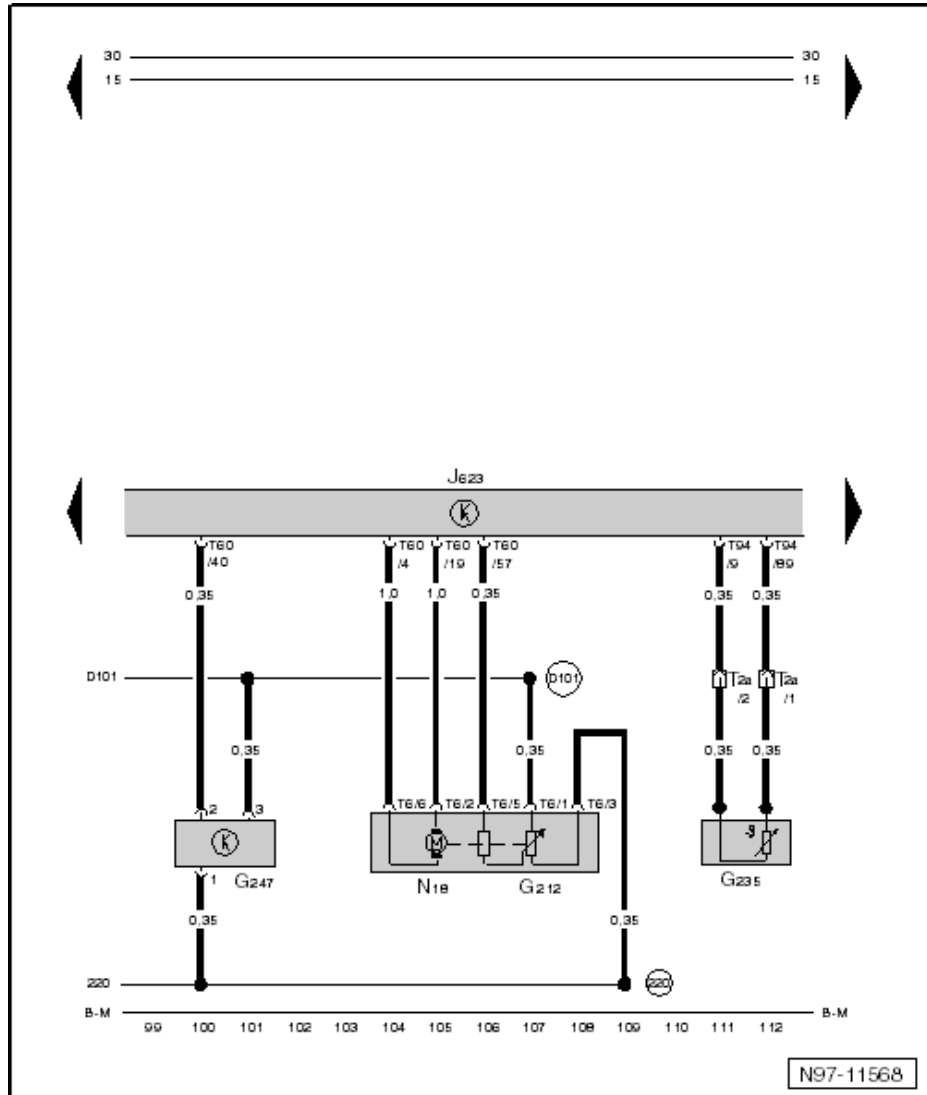



3.1.9 Brake light switch, brake pedal switch, engine control unit, charge pressure control solenoid valve, crankcase breather heater element

- F** - Brake light switch
- F47**-Brake pedal switch
 - * Safety circuit
- J67**-Brake system control blocking diode
- J111**-Brake light relay
 - ** When installed (customer specific)
- J623**-Engine control unit
- N75**-Charge pressure control solenoid valve
- N79**-Heater element for crankcase breather
 - ** When installed.
- S12**-Fuse
 - 10 A
 - In fuse holder.
 - ** When installed.
- T1** - Single connector
- T14**-14-pin connector
- T60**-60-pin connector
- T94**-94-pin connector
- B633**-Connection (brake pedal switch) in main wiring harness
- ***-Output brake light, terminal 31b
- B-M**-Battery earth/engine earth

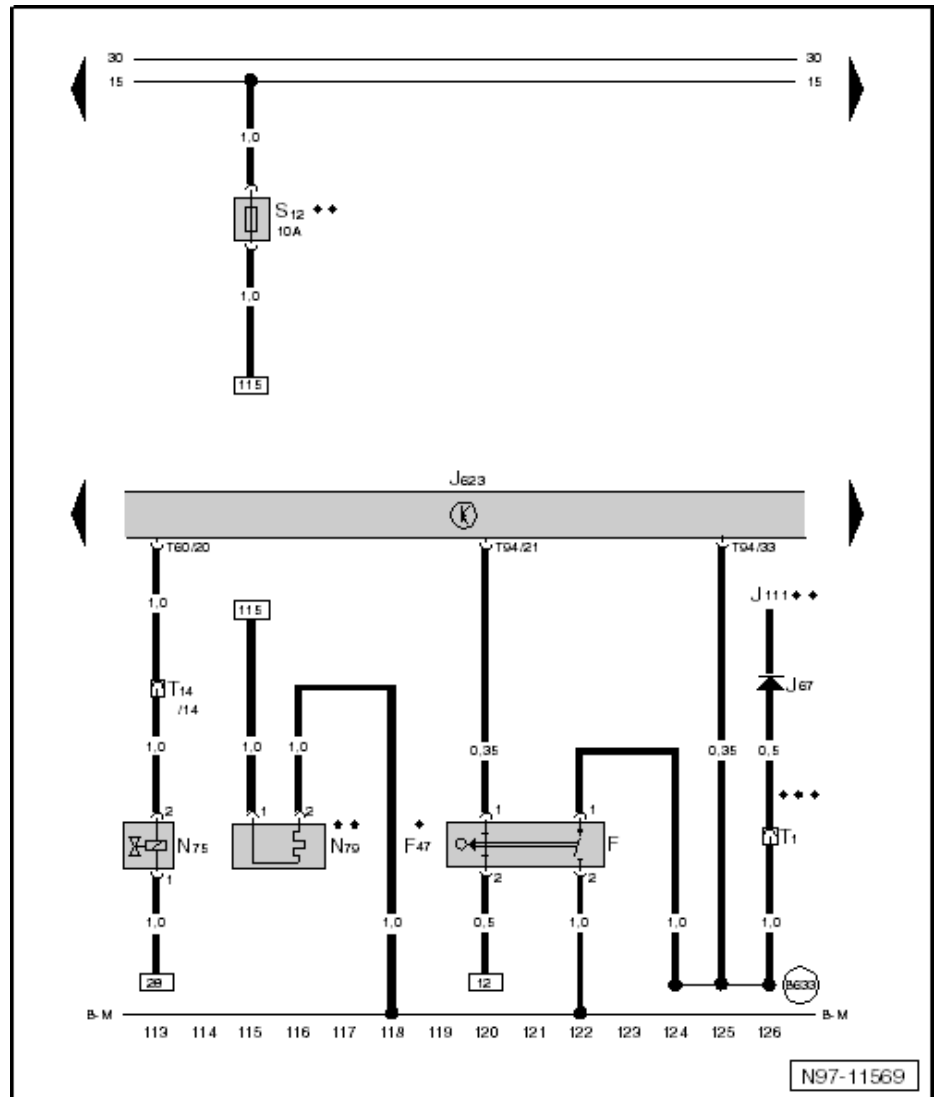



3.1.10 Working speed control switch, working speed control, resume button, preset revolutions 1 and 2 switch , clutch pedal switch, engine control unit

E261-Working speed control switch

E426-Working speed control, resume button

E433-Preset speed 1 switch

E434-Preset speed 2 switch

F36-Clutch pedal switch

J623-Engine control unit

T14-14-pin connector

T60-60-pin connector

T94-94-pin connector

A143-Connection (working speed control), in dash panel wiring harness

B-M-Battery earth/engine earth

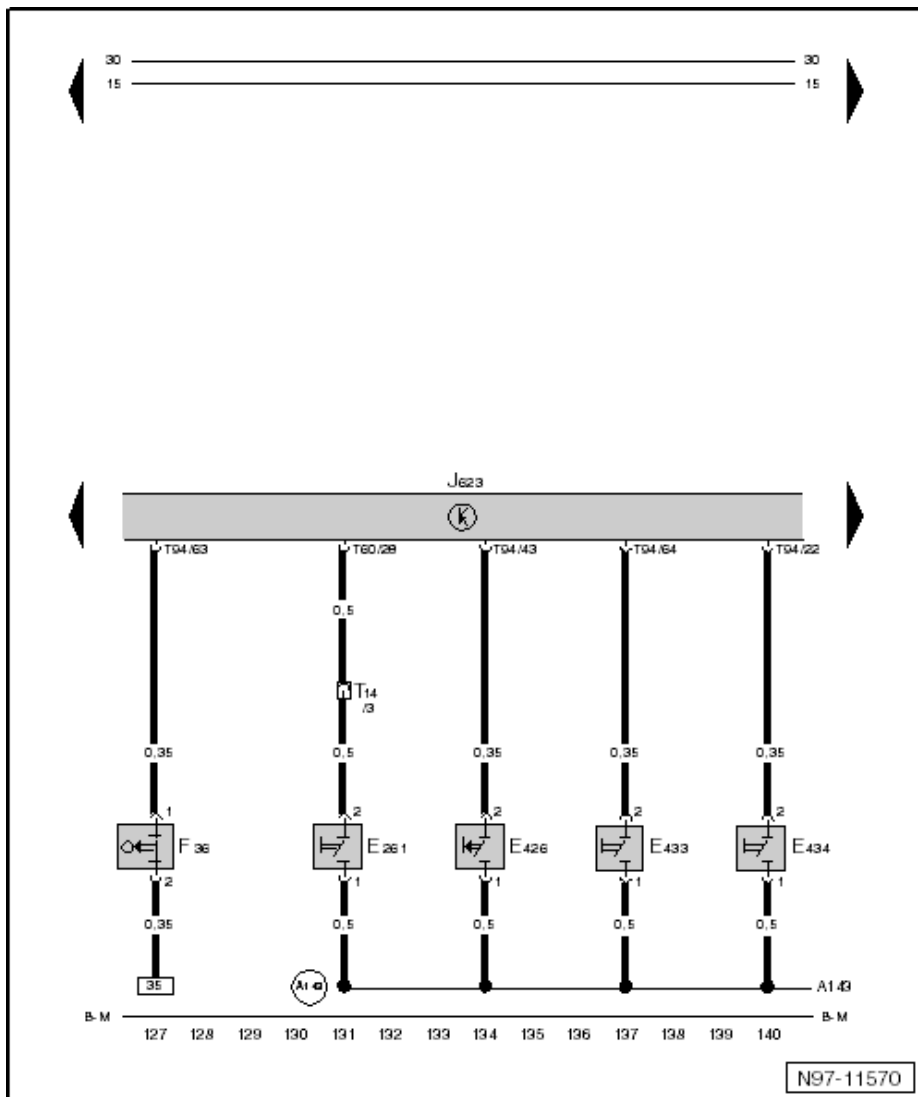



3.1.11 Preset revolution 3 switch, engine control unit, alternator warning lamp, glow period warning lamp, exhaust emissions warning lamp

- E435-Preset speed 3 switch
- J623-Engine control unit
- K2- Warning lamp for alternator
- K29-Warning lamp for preliminary heating time
- K83-Exhaust gas warning lamp
- T94-94-pin connector
- A143-Connection (working speed control), in dash panel wiring harness
- D52-Positive connection (15a), in engine compartment wiring harness
- B-M-Battery earth/engine earth

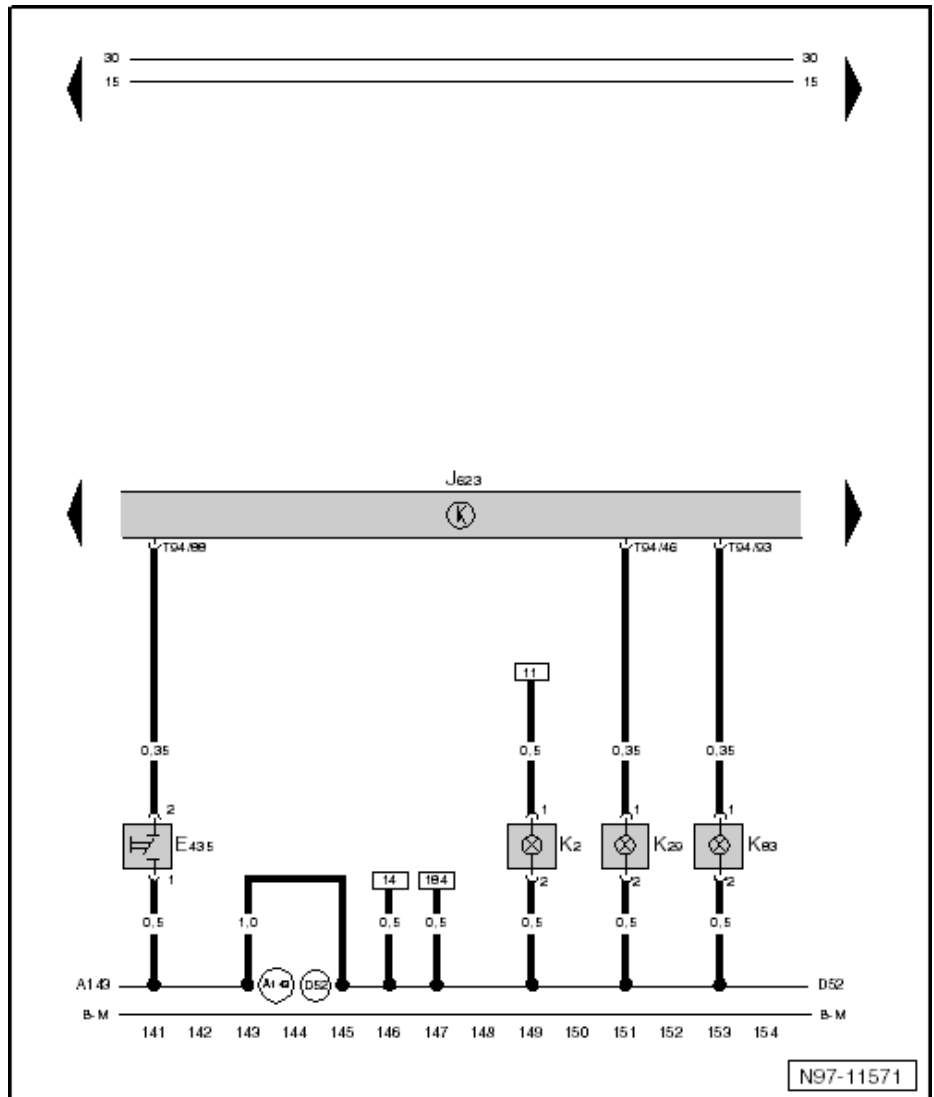



3.1.12 Working speed control, safety contact switch, working speed control, decrease speed button, working speed control, increase speed button, working speed control switch 2, engine control unit, working speed control warning lamp

- E427-Working speed control, safety contact switch
- E428-Working speed control, decrease speed button
- E429-Working speed control, increase speed button
- E604-Working speed control switch 2
- J623-Engine control unit
- K158-Working speed control warning lamp
- T14-14-pin connector
- T60-60-pin connector
- T94-94-pin connector
- D52-Positive connection (15a), in engine compartment wiring harness
- B-M-Battery earth/engine earth

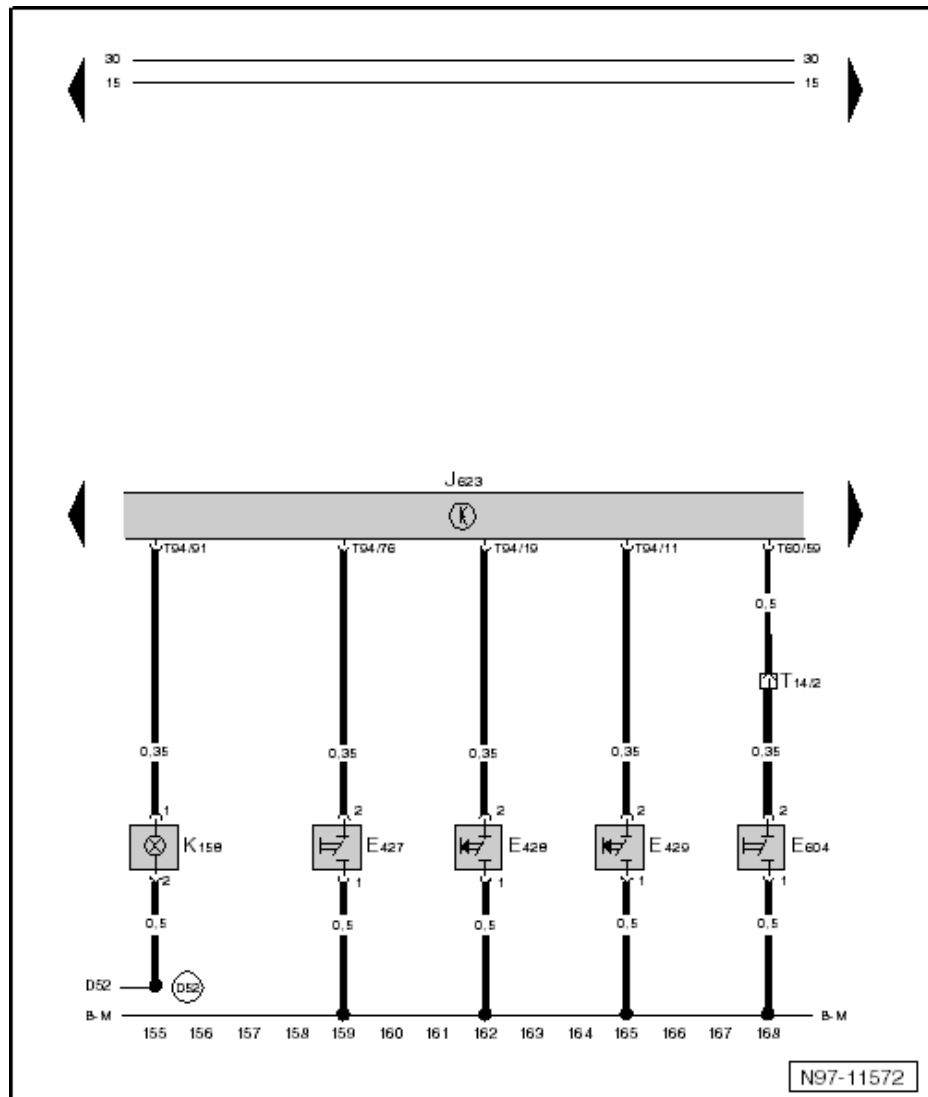



3.1.13 Coding bridges, radiator fan relay, engine control unit, radiator fan single fuse, radiator fan

- J26-Radiator fan relay**
- J623-Engine control unit**
- S...- Fuse**
 - 5 A
 - In fuse holder.
- S42-Radiator fan single fuse**
 - * Fuse rating is dependant on type of radiator fan
- T14-14-pin connector**
- T60-60-pin connector**
- T94-94-pin connector**
- V7- Radiator fan**
- B-M-Battery earth/engine earth**

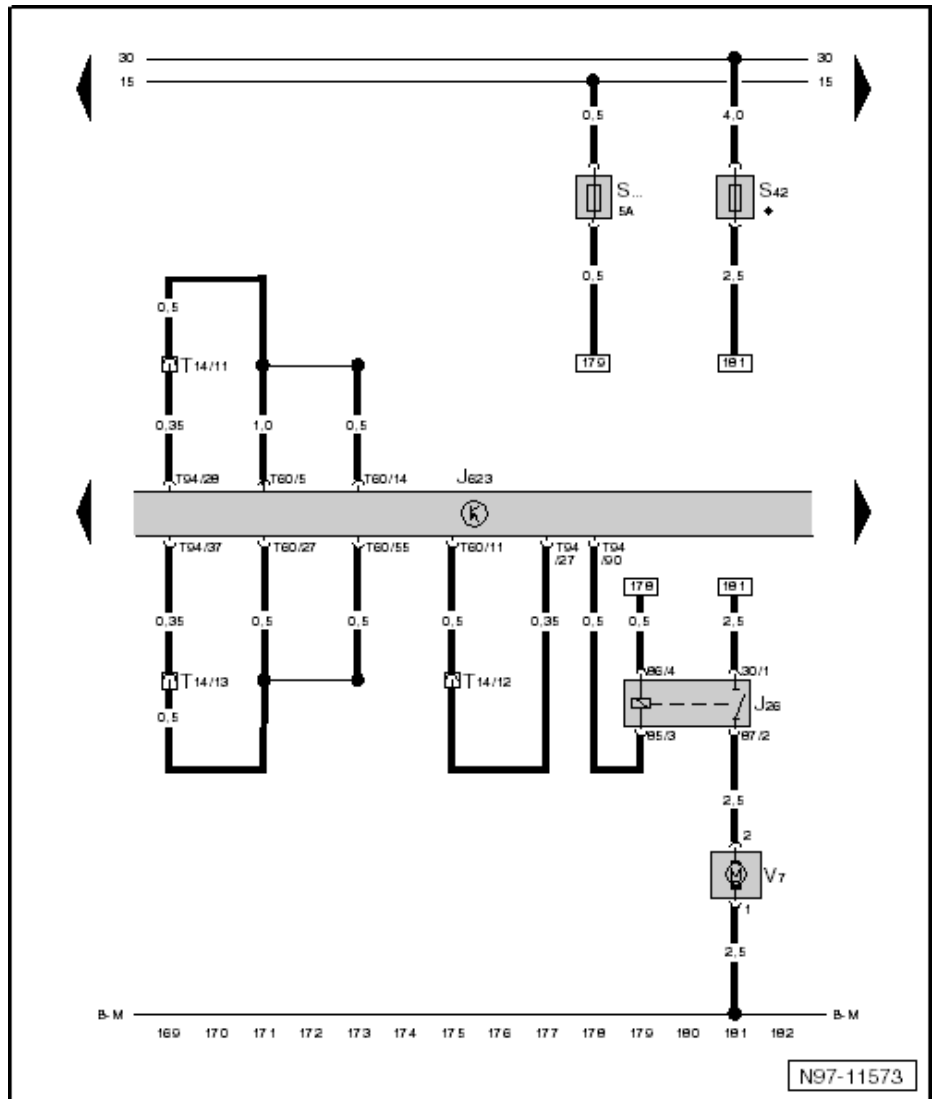



3.1.14 Diagnosis connection, oil pressure switch, engine control unit, oil pressure warning lamp

- F1 - Oil pressure switch
- J150-Oil pressure monitor delay relay
 - * Customer specific
- J623-Engine control unit
- K3- Oil pressure warning lamp
- S...- Fuse
 - 5 A
 - In fuse holder.
- T14-14-pin connector
- T16-16-pin connector
 - Diagnostic connection
- T94-94-pin connector
 - * - Customer specific
 - ** - Output rev. signal
- B-M-Battery earth/engine earth

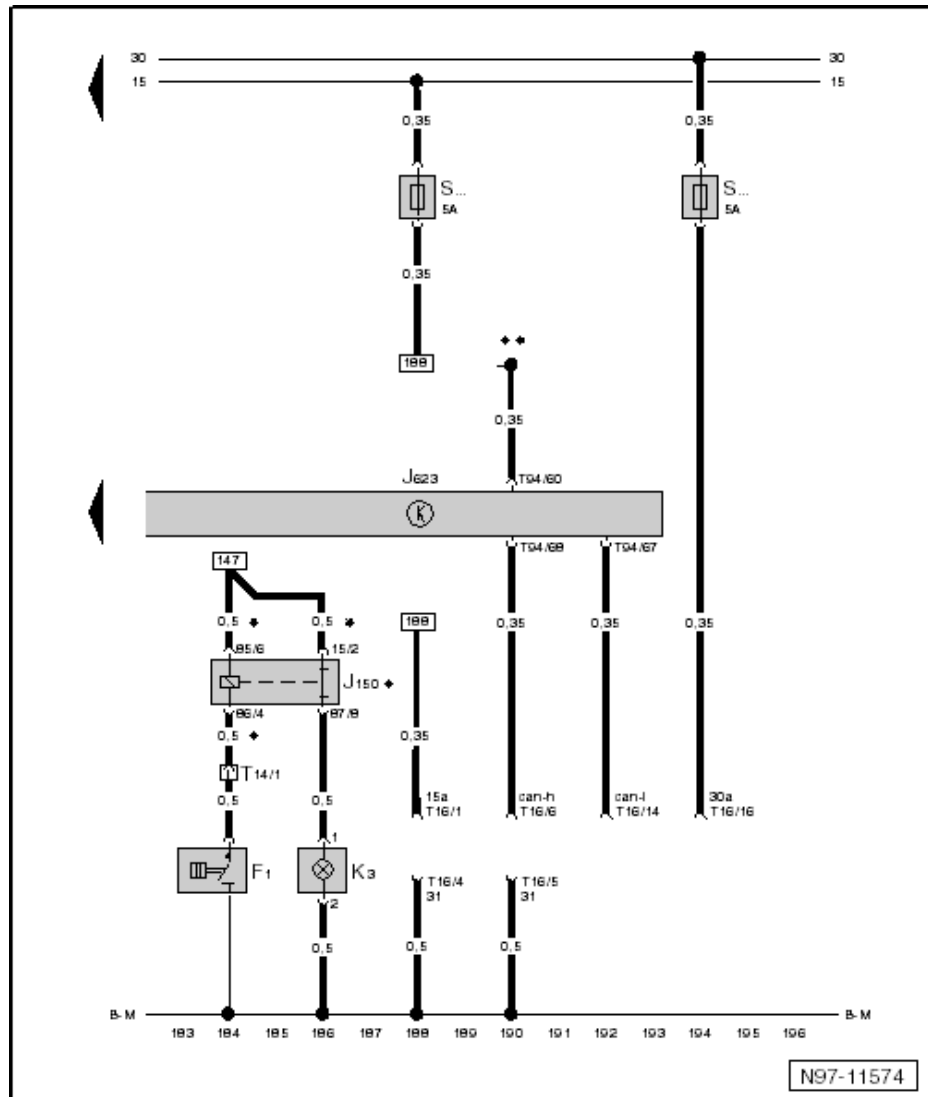

3.2 Current flow diagrams: Engine code CJDA (EU 5)

Battery, starter, alternator, voltage regulator, ignition/starter switch ⇒ [page 322](#).

Electric fuel pump 2 relay, automatic glow period control unit, glow plugs, fuses, supplementary fuel pump ⇒ [page 323](#).

Terminal 30 voltage supply relay, engine control unit, fuses ⇒ [page 324](#).

Coding bridges, charge air pressure sender, intake air temperature sender, air mass meter, engine control unit ⇒ [page 325](#).

Accelerator position sender, accelerator position sender 2, engine control unit, injectors for cylinders 1...4 ⇒ [page 326](#).



Hall sender, coolant temperature sender, engine control unit, fuel pressure regulating valve, fuel metering valve
⇒ [page 327](#).

Engine speed sender, throttle valve potentiometer, fuel temperature sender, position sender for charge pressure positioner, throttle valve module, engine control unit ⇒ [page 328](#).

Exhaust gas recirculation potentiometer, fuel pressure sender, engine control unit, exhaust gas recirculation valve
⇒ [page 329](#).

Exhaust gas temperature sender 1, exhaust gas temperature sender 3, exhaust gas temperature sender 4, engine control unit ⇒ [page 330](#).

Lambda probe, exhaust gas pressure sensor 1, engine control unit, Lambda probe heater ⇒ [page 331](#).

Brake light switch, brake pedal switch, engine control unit, charge pressure control solenoid valve, crankcase breather heater element ⇒ [page 332](#).

Working speed control switch, working speed control, resume button, preset revolutions 1 and 2 switch, clutch pedal switch, engine control unit ⇒ [page 333](#).

Preset revolution 3 switch, engine control unit, alternator warning lamp, glow period warning lamp, exhaust emissions warning lamp, diesel particulate filter warning lamp
⇒ [page 334](#).

Working speed control, safety contact switch, working speed control, decrease speed button, working speed control, increase speed button, working speed control switch 2, engine control unit, working speed control warning lamp
⇒ [page 335](#).

Coding bridges, radiator fan relay, engine control unit, radiator fan single fuse, radiator fan ⇒ [page 336](#).

Diagnosis connection, oil pressure switch, engine control unit, oil pressure warning lamp ⇒ [page 337](#).



3.2.1 Battery, starter, alternator, voltage regulator, ignition/starter switch fuses

- A - Battery
- B - Starter
- C - Alternator
- C1 - Voltage regulator
- D - Ignition/starter switch
- S5 - Fuse
 - 15 A
 - In fuse holder.
- S8 - Fuse
 - 5 A
 - In fuse holder.
- S10 - Fuse
 - 5 A
 - In fuse holder.
- B-M - Battery earth/engine earth

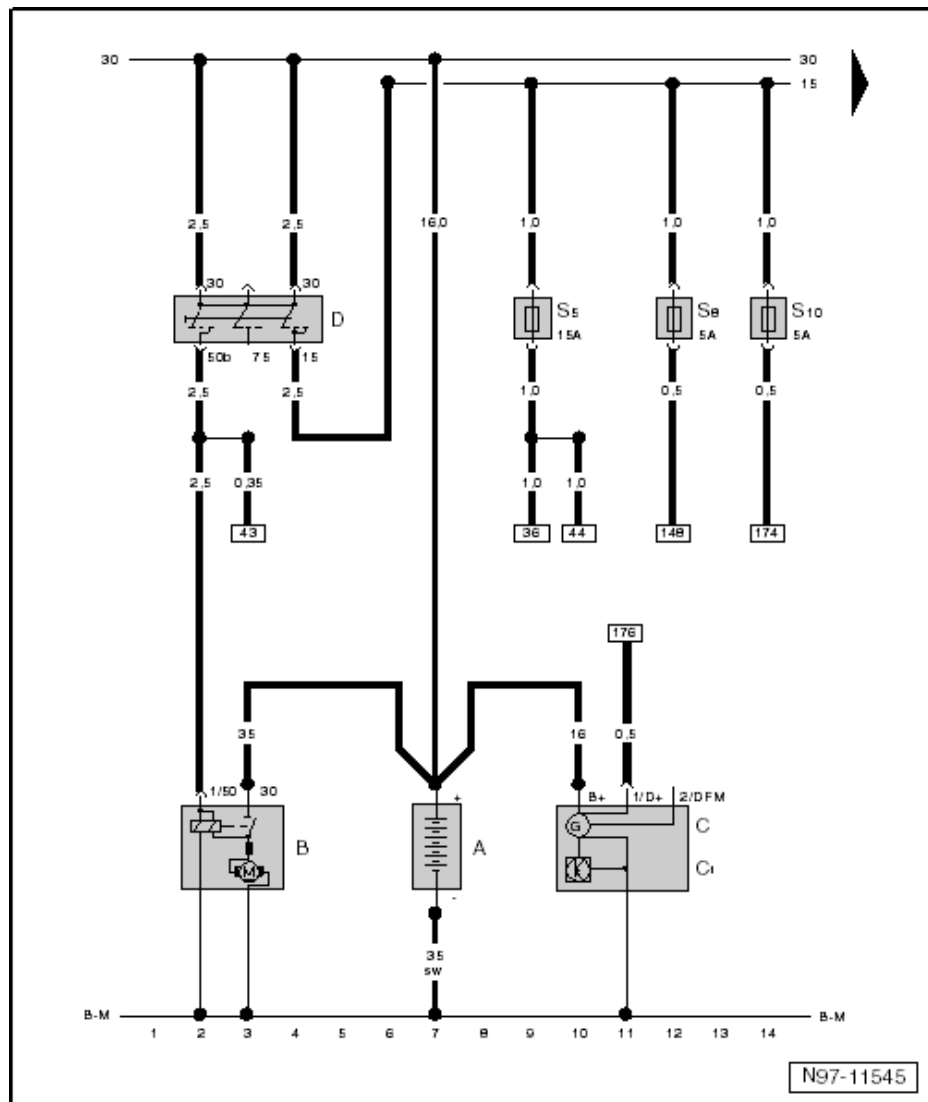



3.2.2 Electric fuel pump 2 relay, automatic glow period control unit, glow plugs, fuses, supplementary fuel pump

- J49-Electric fuel pump 2 relay
- J179-Automatic glow period control unit
- Q10-Glow plug 1
- Q11-Glow plug 2
- Q12-Glow plug 3
- Q13-Glow plug 4
- S1 - Fuse
 - 20 A
 - In fuse holder.
- S3 - Fuse
 - 50 A
 - In fuse holder.
- T4a-4-pin connector
- T11-11-pin connector
- T14-14-pin connector
- V393-Supplementary fuel pump
- B-M-Battery earth/engine earth

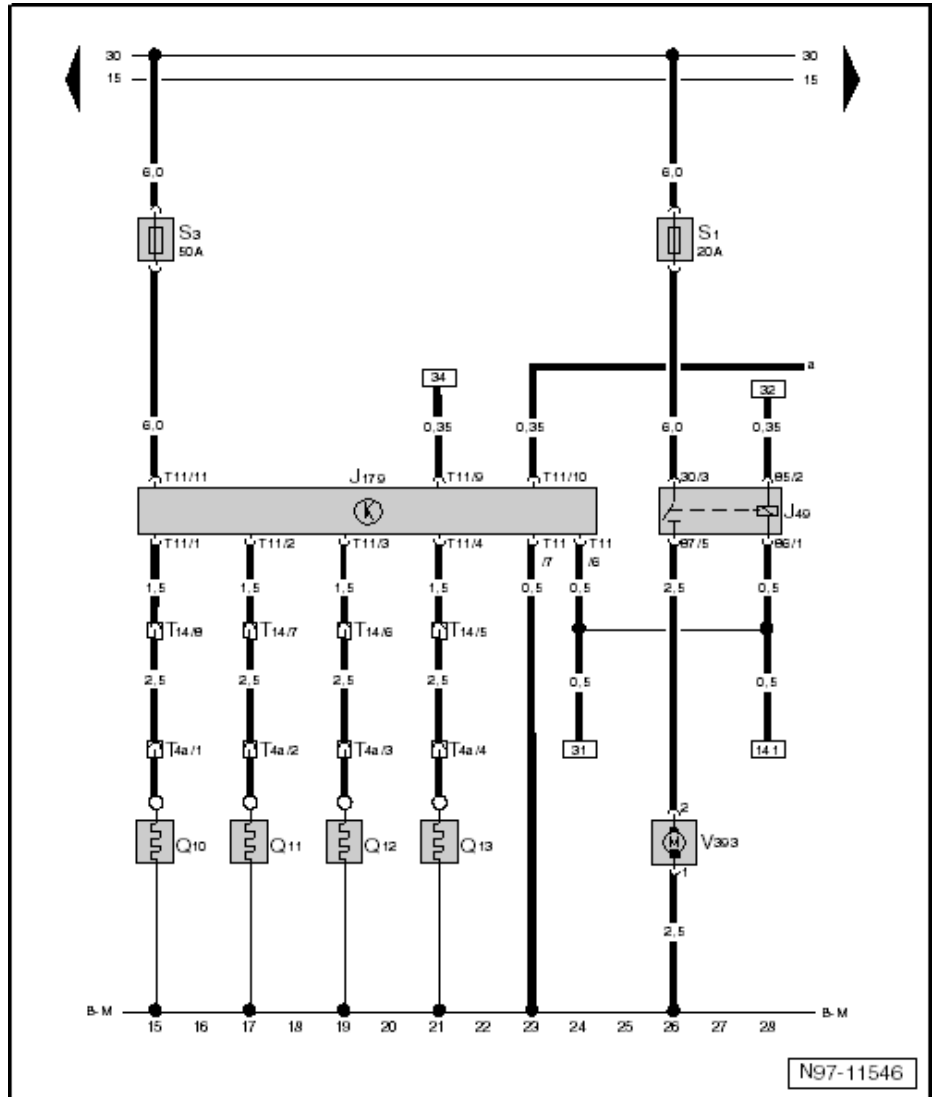



3.2.3 Terminal 30 voltage supply relay, engine control unit, fuses

J317-Terminal 30 voltage supply relay

J623-Engine control unit

S2- Fuse

- 20 A
- In fuse holder.

S4- Fuse

- 15 A
- In fuse holder.

S6- Fuse

- 5 A
- In fuse holder.

S7- Fuse

- 30 A
- In fuse holder.

S9- Fuse

- 5 A
- In fuse holder.

S11-Fuse

- 10 A
- In fuse holder.

T14-14-pin connector

T60-60-pin connector

T94-94-pin connector

131-Earth connection 2, in engine compartment wiring harness

D180-Connection (87a), in engine compartment wiring harness

D182-Connection 3 (87a), in engine compartment wiring harness

B-M-Battery earth/engine earth

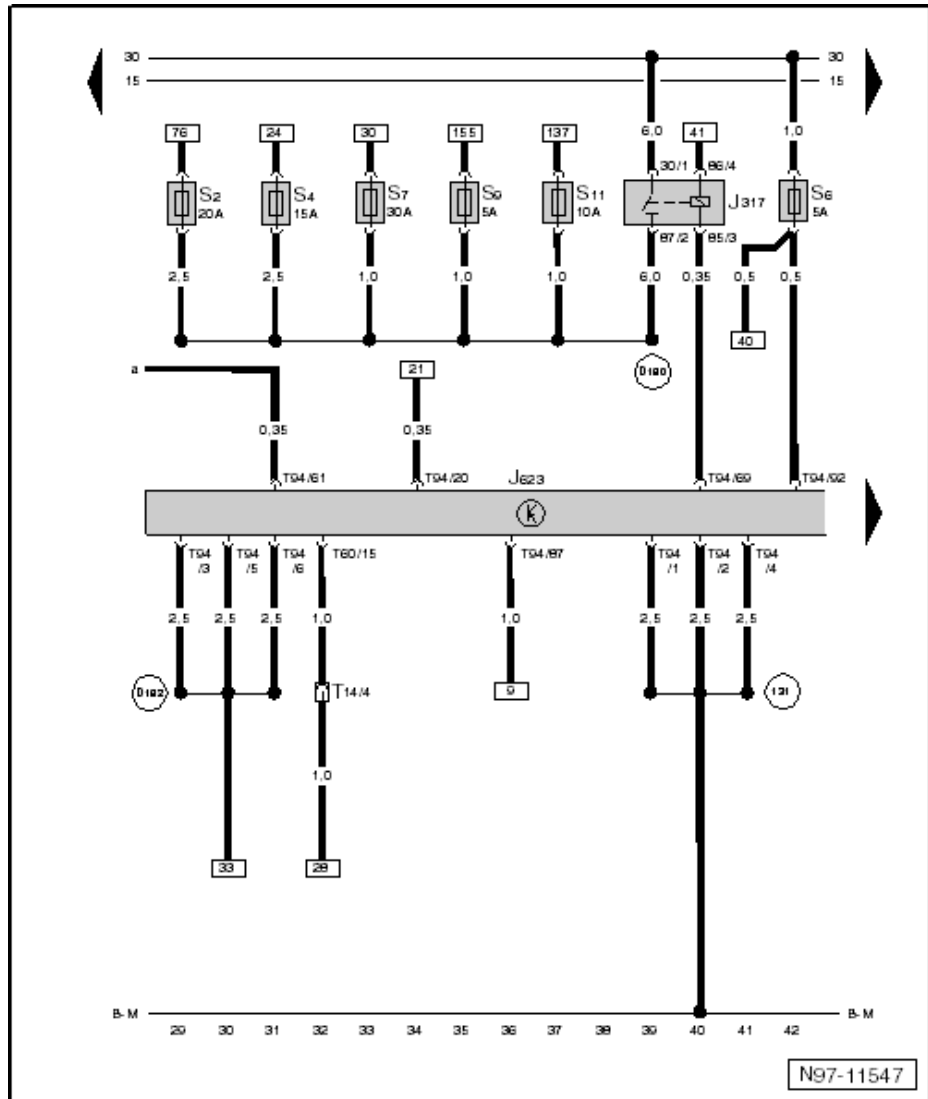



3.2.4 Coding bridges, charge air pressure sender, intake air temperature sender, air mass meter, engine control unit

- G31-Charge air pressure sender
- G42-Intake air temperature sender
- G70-Air mass meter
- J623-Engine control unit
- T5- 5-pin connector
- T94-94-pin connector
- B-M-Battery earth/engine earth

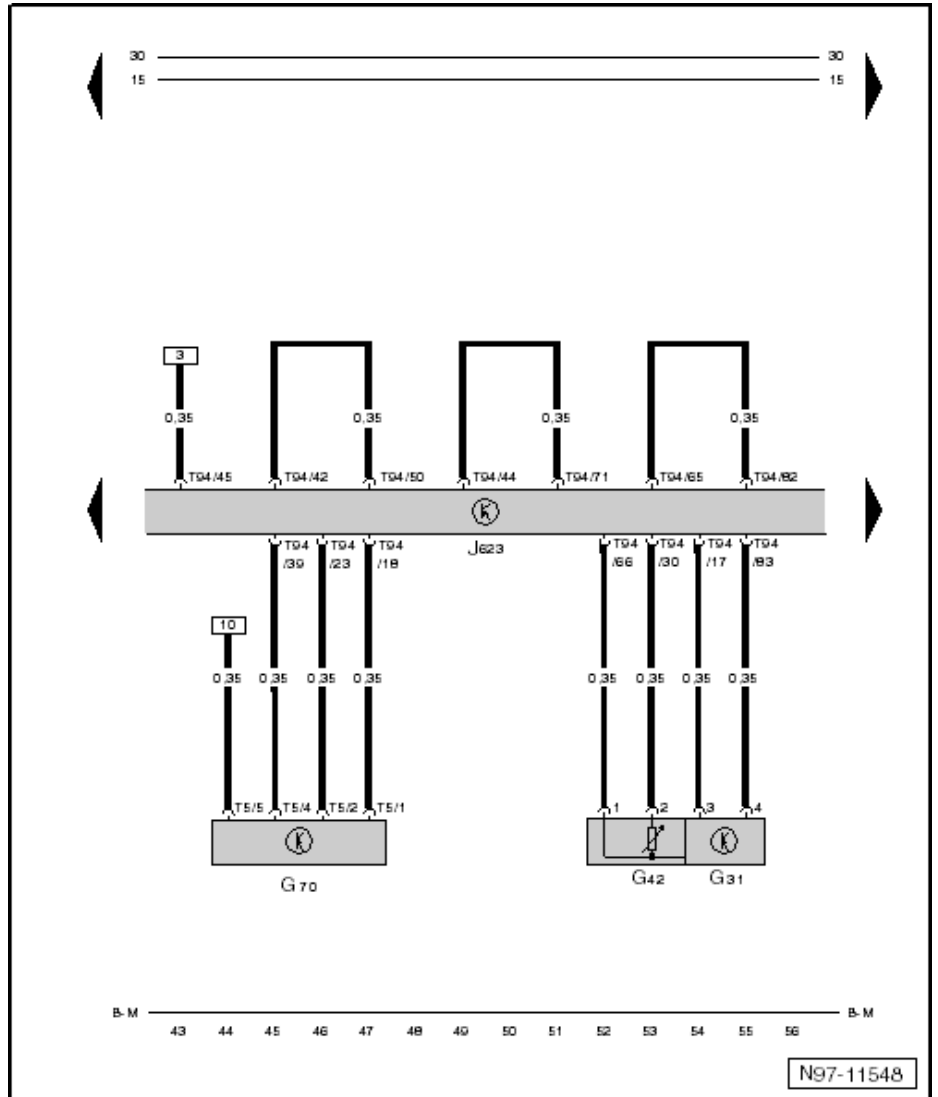



3.2.5 Accelerator position sender, accelerator position sender 2, engine control unit, injectors for cylinders 1...4

- G79-Accelerator position sender
- G185-Accelerator position sender 2
- J623-Engine control unit
- N30-Injector, cylinder 1
- N31-Injector, cylinder 2
- N32-Injector, cylinder 3
- N33-Injector, cylinder 4
- T6a-6-pin connector
- T60-60-pin connector
- T94-94-pin connector
- B-M-Battery earth/engine earth

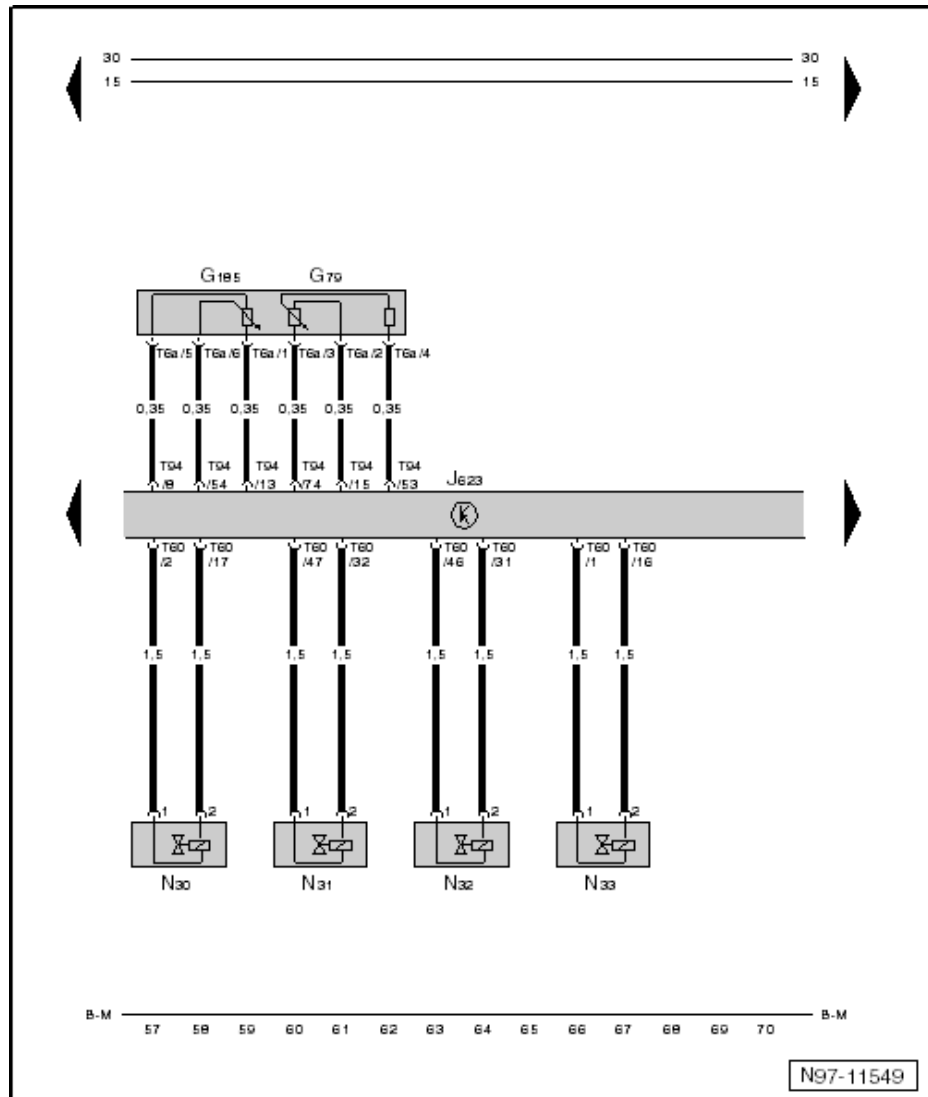



3.2.6 Hall sender, coolant temperature sender, engine control unit, fuel pressure regulating valve, fuel metering valve

G40-Hall sender

G62-Coolant temperature sender

J623-Engine control unit

N276-Fuel pressure regulating valve

N290-Fuel metering valve

T3 - 3-pin connector

T14- 14-pin connector

T60-60-pin connector

B-M-Battery earth/engine earth

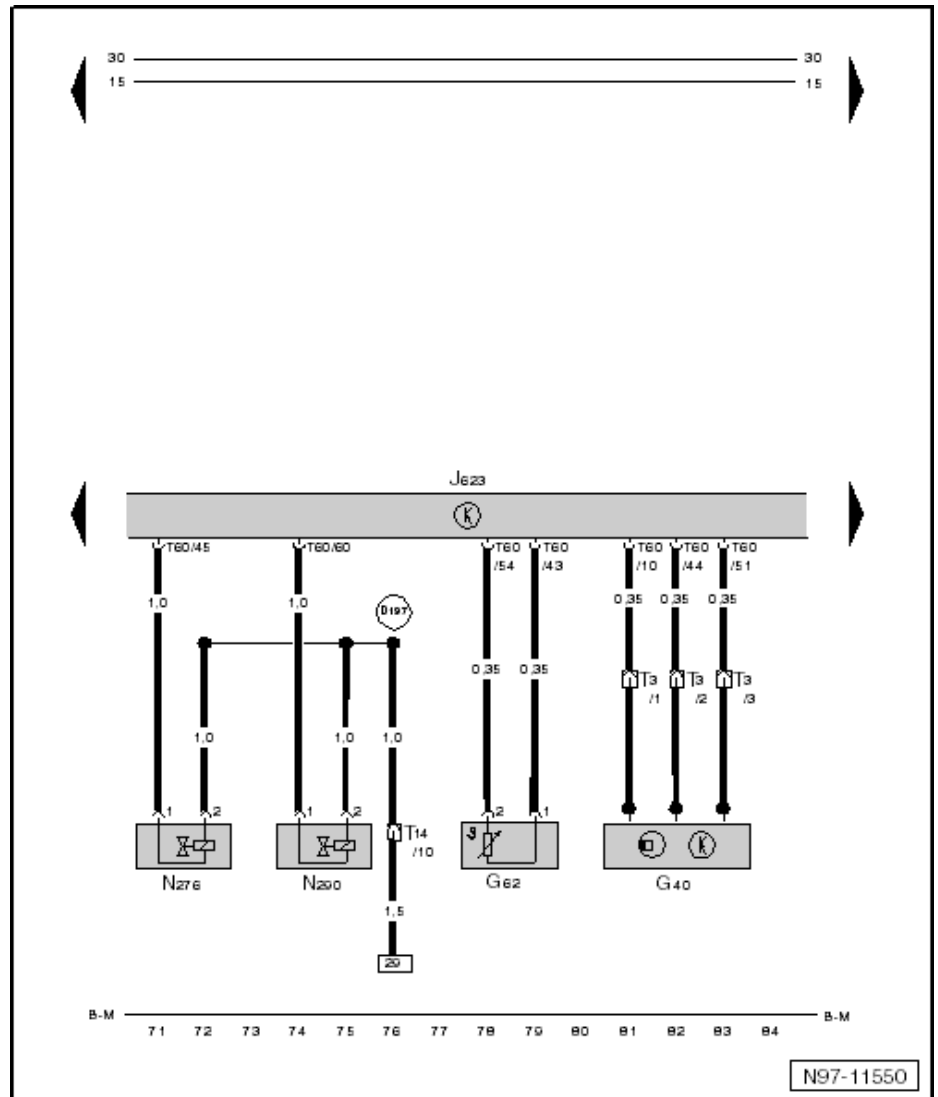



3.2.7 Engine speed sender, throttle valve potentiometer, fuel temperature sender, position sender for charge pressure positioner, throttle valve module, engine control unit

- G28-Engine speed sender
- G69-Throttle valve potentiometer
- G81-Fuel temperature sender
- G581-Position sender for charge pressure positioner
- J338-Throttle valve module
- J623-Engine control unit
- T60-60-pin connector
- 220-Earth connection (sender earth), in engine wiring harness
- D101-Connection 1, in engine compartment wiring harness
- B-M-Battery earth/engine earth

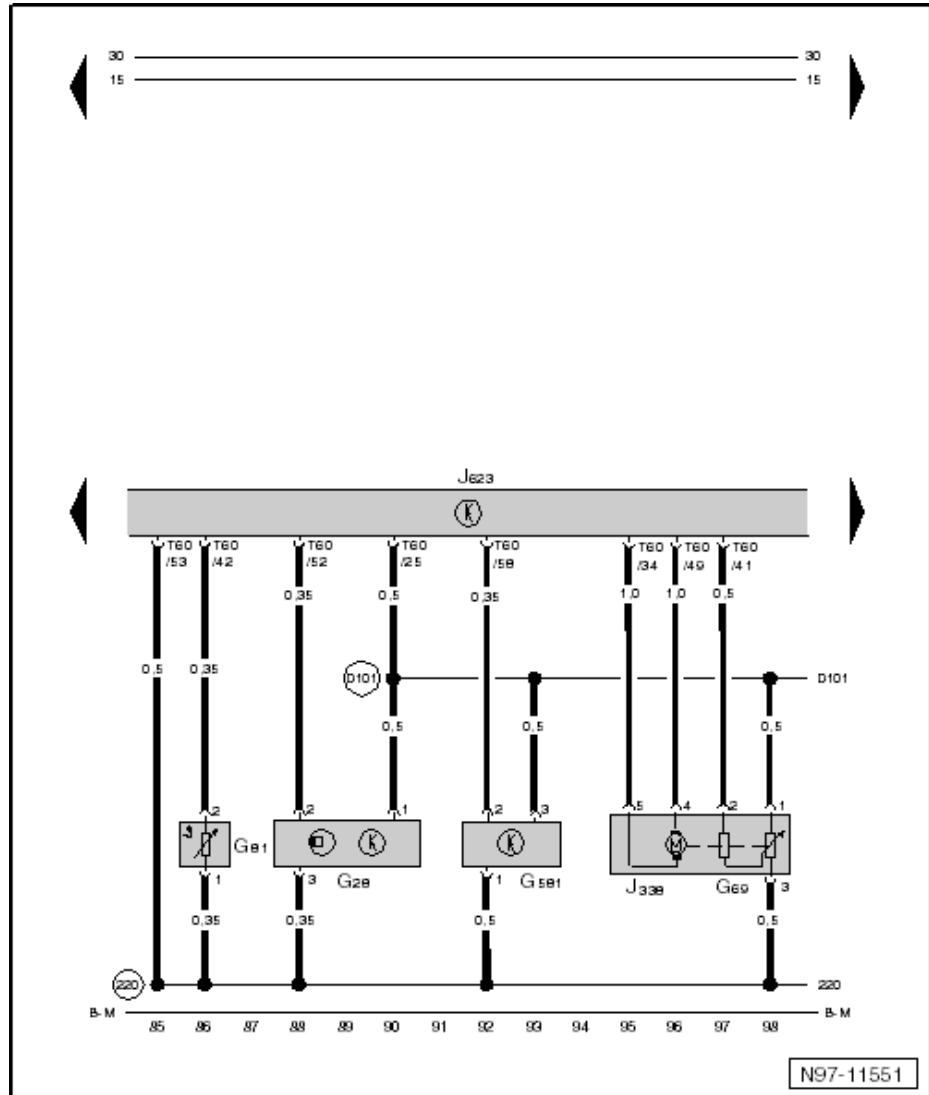



3.2.8 Exhaust gas recirculation potentiometer, fuel pressure sender, engine control unit, exhaust gas recirculation valve

- G212-Potentiometer for exhaust gas recirculation
- G247-Fuel pressure sender
- J623-Engine control unit
- N18-Exhaust gas recirculation valve
- T6 - 6-pin connector
- T60-60-pin connector
- 220-Earth connection (sender earth), in engine wiring harness
- D101-Connection 1, in engine compartment wiring harness
- B-M-Battery earth/engine earth

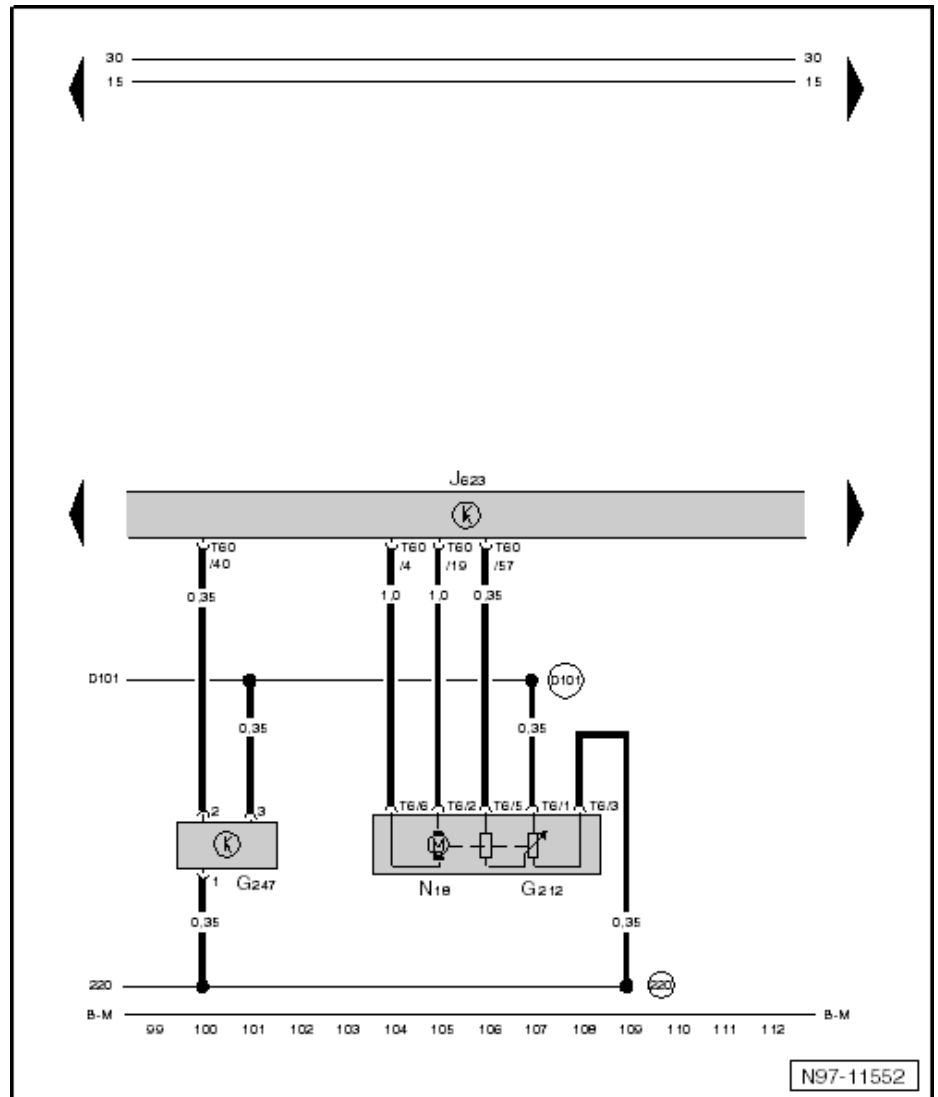



3.2.9 Exhaust gas temperature sender 1, exhaust gas temperature sender 3, exhaust gas temperature sender 4, engine control unit

- G235-Exhaust gas temperature sender 1
- G495-Exhaust gas temperature sender 3
- G648-Exhaust gas temperature sender 4
- J623-Engine control unit
- T2a-2-pin connector
- T2b-2-pin connector
- T2c-2-pin connector
- T94-94-pin connector
- 327-Earth connection (sender earth), in engine wiring harness
- B-M-Battery earth/engine earth

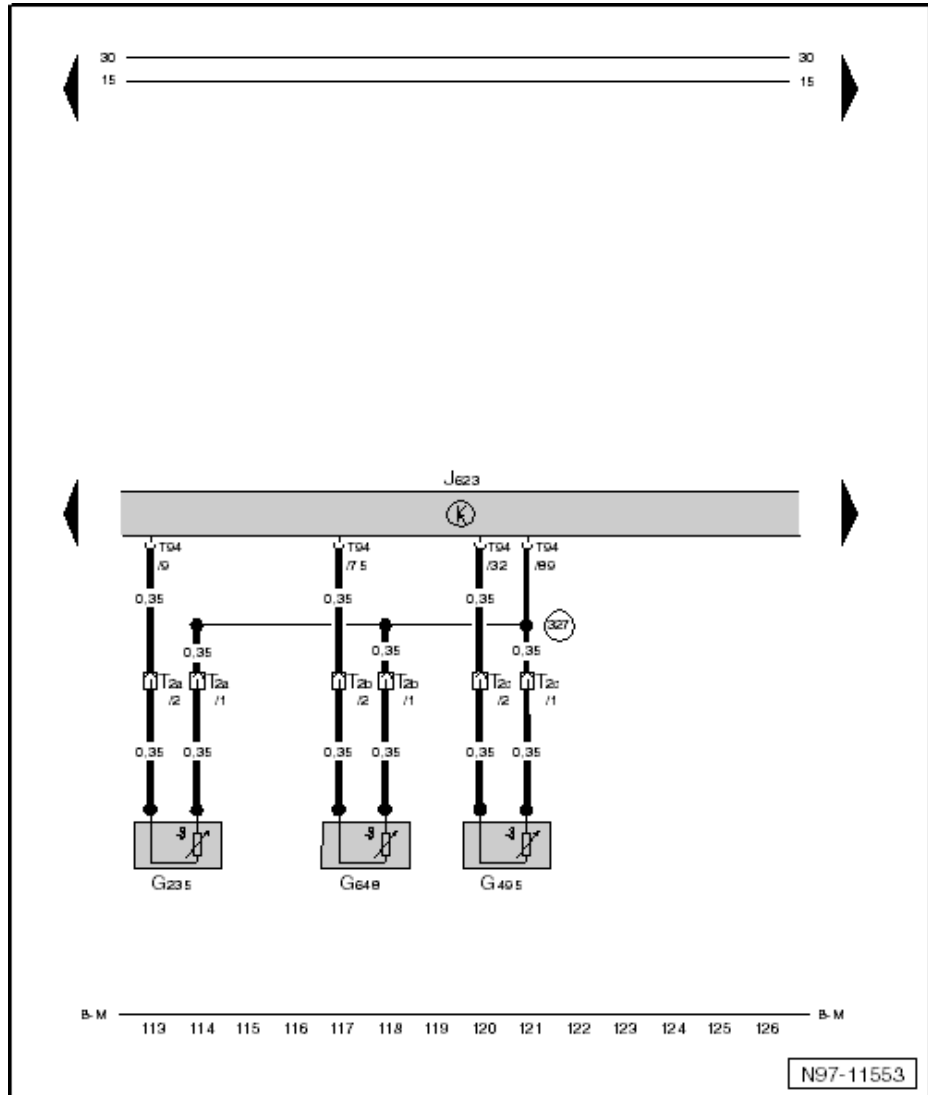



3.2.10 Lambda probe, exhaust gas pressure sensor 1, engine control unit, Lambda probe heater

- G39-Lambda probe
- G450-Exhaust gas pressure sensor 1
- J623-Engine control unit
- Z19-Lambda probe heater
- T6b-6-pin connector
- T94-94-pin connector
- B-M-Battery earth/engine earth

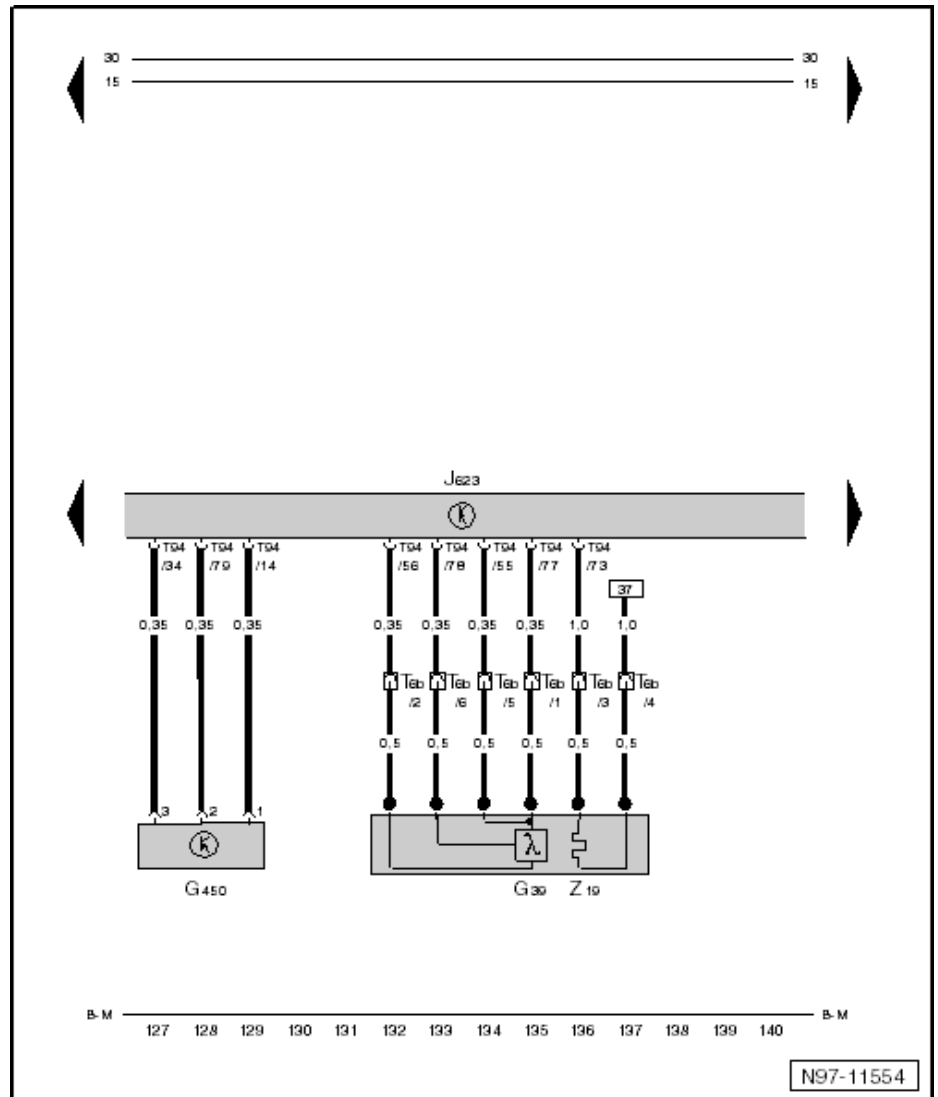



3.2.11 Brake light switch, brake pedal switch, engine control unit, charge pressure control solenoid valve, crankcase breather heater element

- F - Brake light switch**
- F47-Brake pedal switch**
 - ☐ * Safety circuit
- J67-Brake system control blocking diode**
- J111-Brake light relay**
 - ☐ ** When installed (customer specific)
- J623-Engine control unit**
- N75-Charge pressure control solenoid valve**
- N79-Heater element for crankcase breather**
 - ☐ ** When installed.
- S12-Fuse**
 - ☐ 10 A
 - ☐ In fuse holder.
 - ☐ ** When installed.
- T1 - Single connector**
- T14-14-pin connector**
- T60-60-pin connector**
- T94-94-pin connector**
- B633-Connection (brake pedal switch) in main wiring harness**
- ***-Output brake light, terminal 31b
- B-M-Battery earth/engine earth**

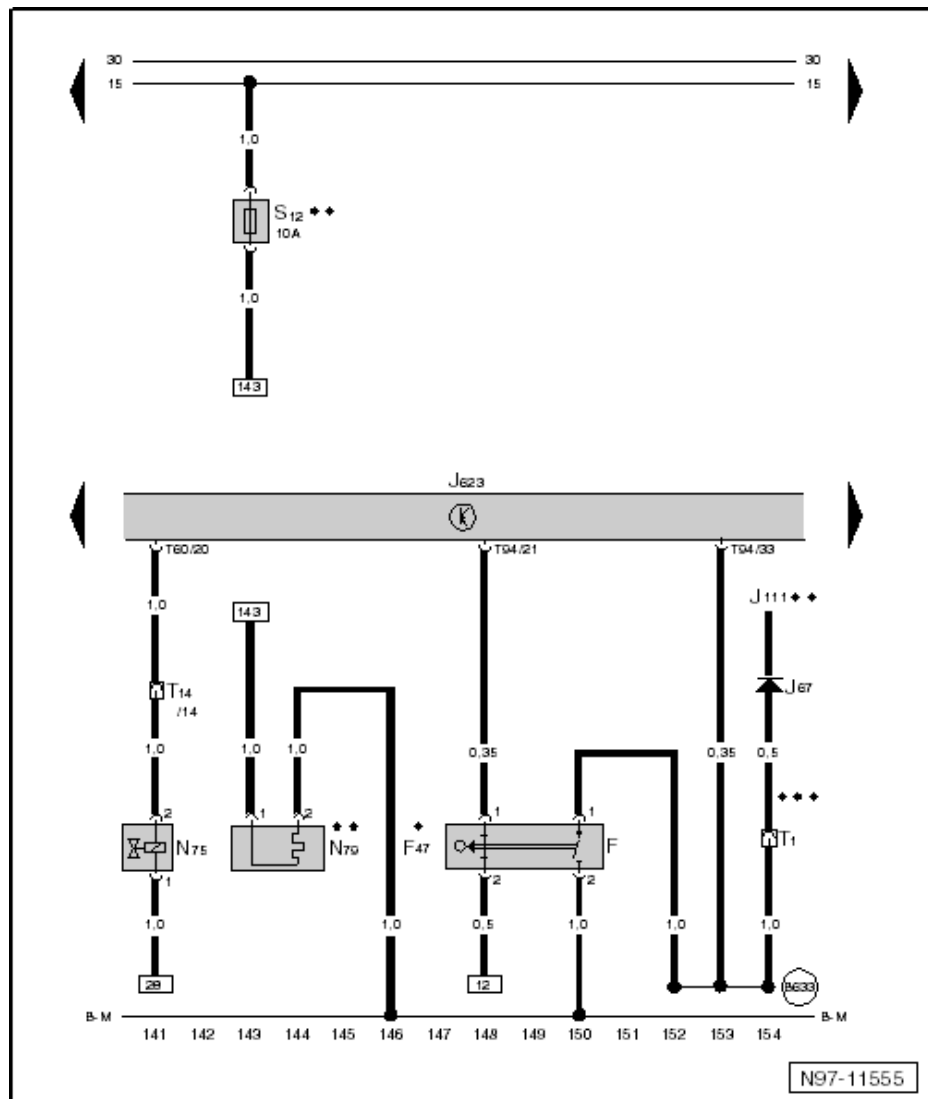



3.2.12 Working speed control switch, working speed control, resume button, preset revolutions 1 and 2 switch, clutch pedal switch, engine control unit

- E261-Working speed control switch
- E426-Working speed control, resume button
- E433-Preset speed 1 switch
- E434-Preset speed 2 switch
- F36-Clutch pedal switch
- J623-Engine control unit
- T14-14-pin connector
- T60-60-pin connector
- T94-94-pin connector
- A143-Connection (working speed control), in dash panel wiring harness
- B-M-Battery earth/engine earth

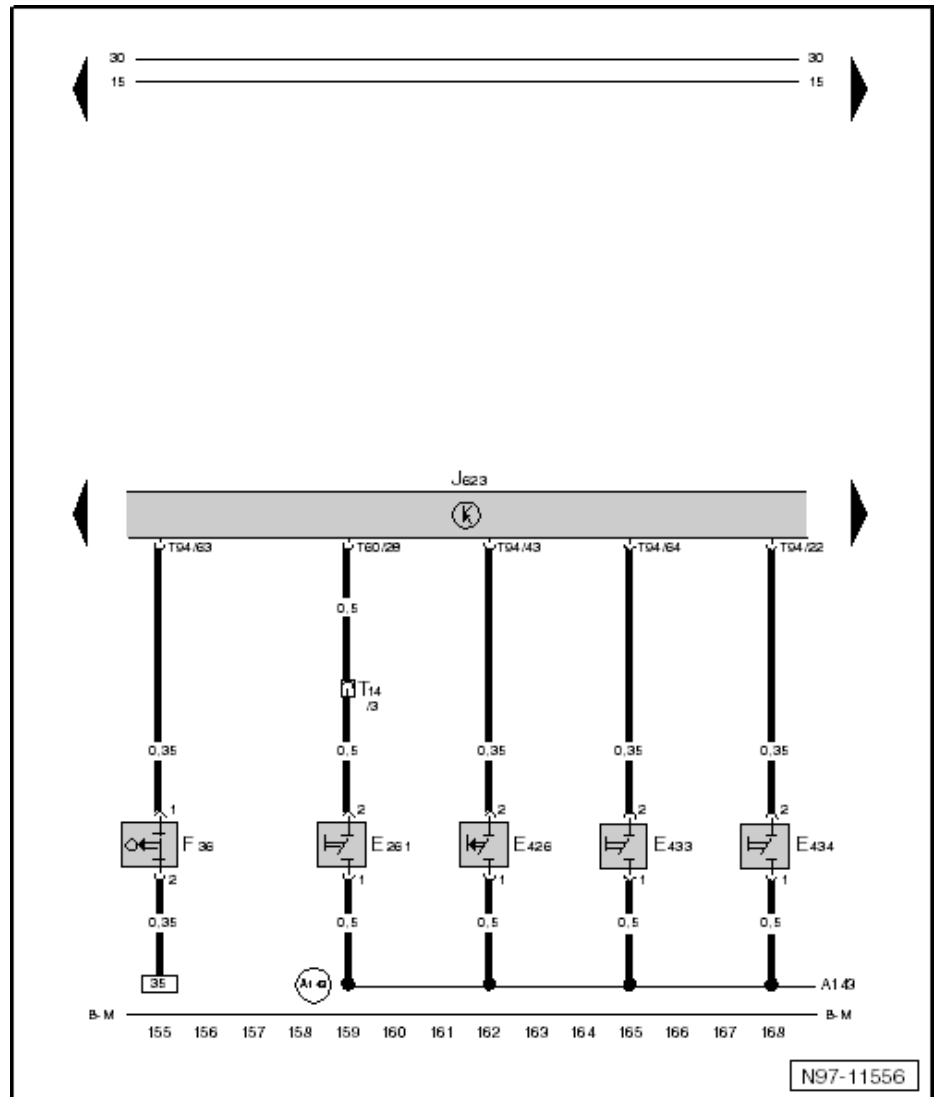



3.2.13 Preset revolution 3 switch, engine control unit, alternator warning lamp, glow period warning lamp, exhaust emissions warning lamp, diesel particulate filter warning lamp

- E435-Preset speed 3 switch
- J623-Engine control unit
- K2- Warning lamp for alternator
- K29-Warning lamp for preliminary heating time
- K83-Exhaust gas warning lamp
- K231-Warning lamp for diesel particle filter
- T14-14-pin connector
- T60-60-pin connector
- T94-94-pin connector
- A143-Connection (working speed control), in dash panel wiring harness
- D52-Positive connection (15a), in engine compartment wiring harness
- B-M-Battery earth/engine earth

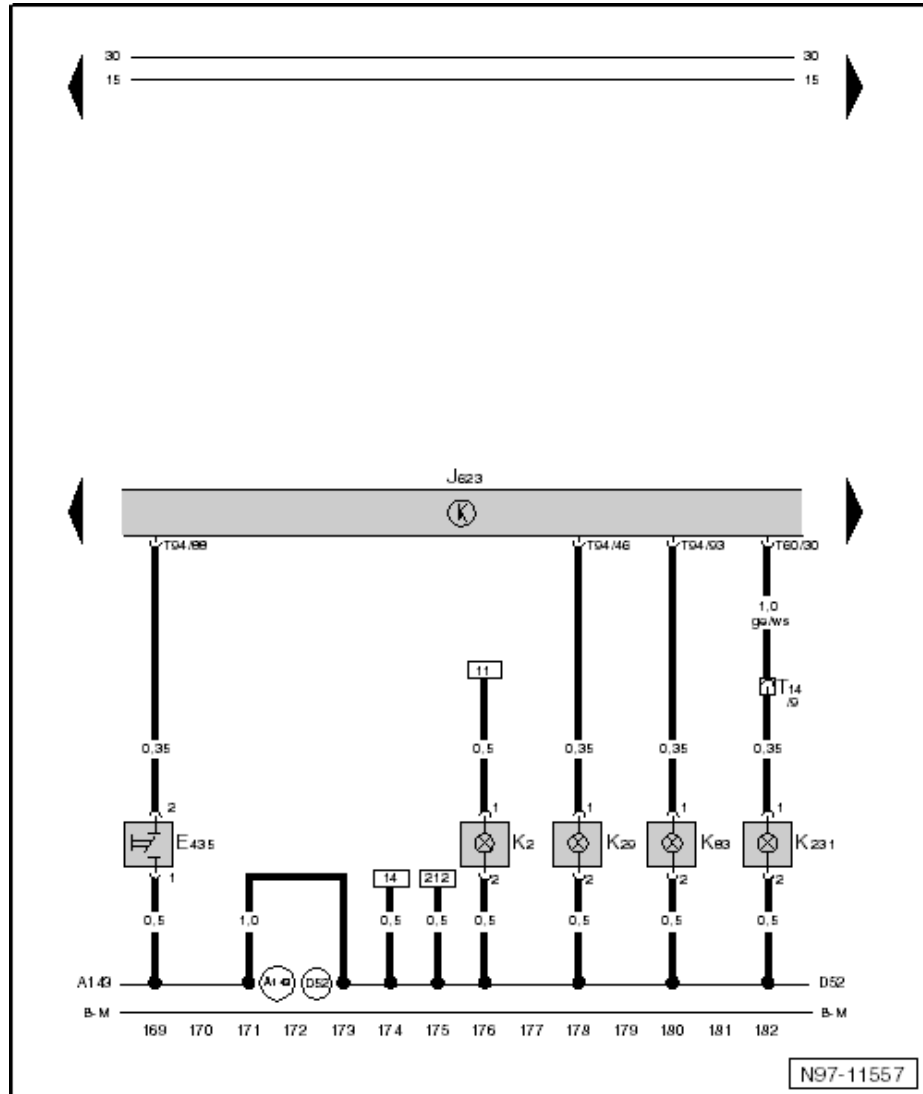



3.2.14 Working speed control, safety contact switch, working speed control, decrease speed button, working speed control, increase speed button, working speed control switch 2, engine control unit, working speed control warning lamp

- E427-Working speed control, safety contact switch
- E428-Working speed control, decrease speed button
- E429-Working speed control, increase speed button
- E604-Working speed control switch 2
- J623-Engine control unit
- K158-Working speed control warning lamp
- T14-14-pin connector
- T60-60-pin connector
- T94-94-pin connector
- D52-Positive connection (15a), in engine compartment wiring harness
- B-M-Battery earth/engine earth

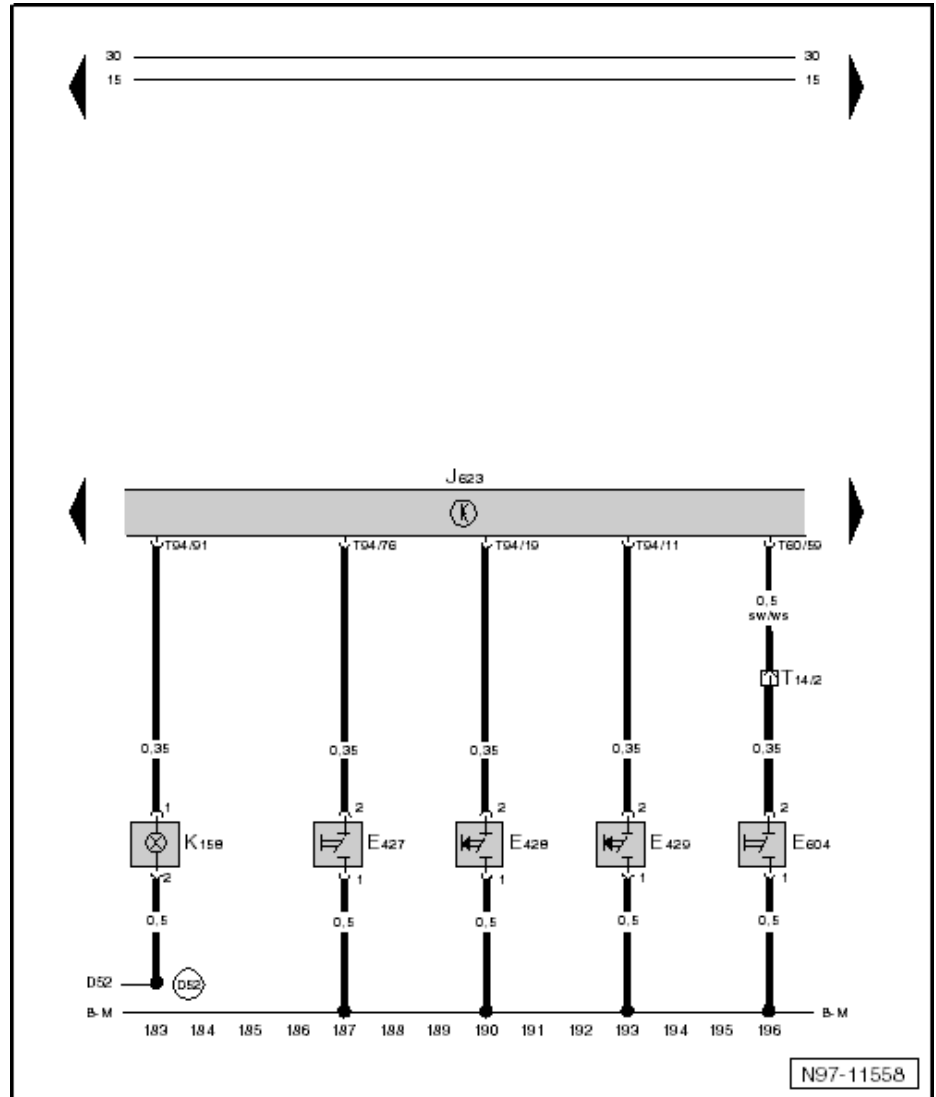

N97-11558



3.2.15 Coding bridges, radiator fan relay, engine control unit, radiator fan single fuse, radiator fan

- J26-Radiator fan relay
- J623-Engine control unit
- S...- Fuse
 - 5 A
 - In fuse holder.
- S42-Radiator fan single fuse
 - * Fuse rating is dependant on type of radiator fan
- T14-14-pin connector
- T60-60-pin connector
- T94-94-pin connector
- V7- Radiator fan
- B-M-Battery earth/engine earth

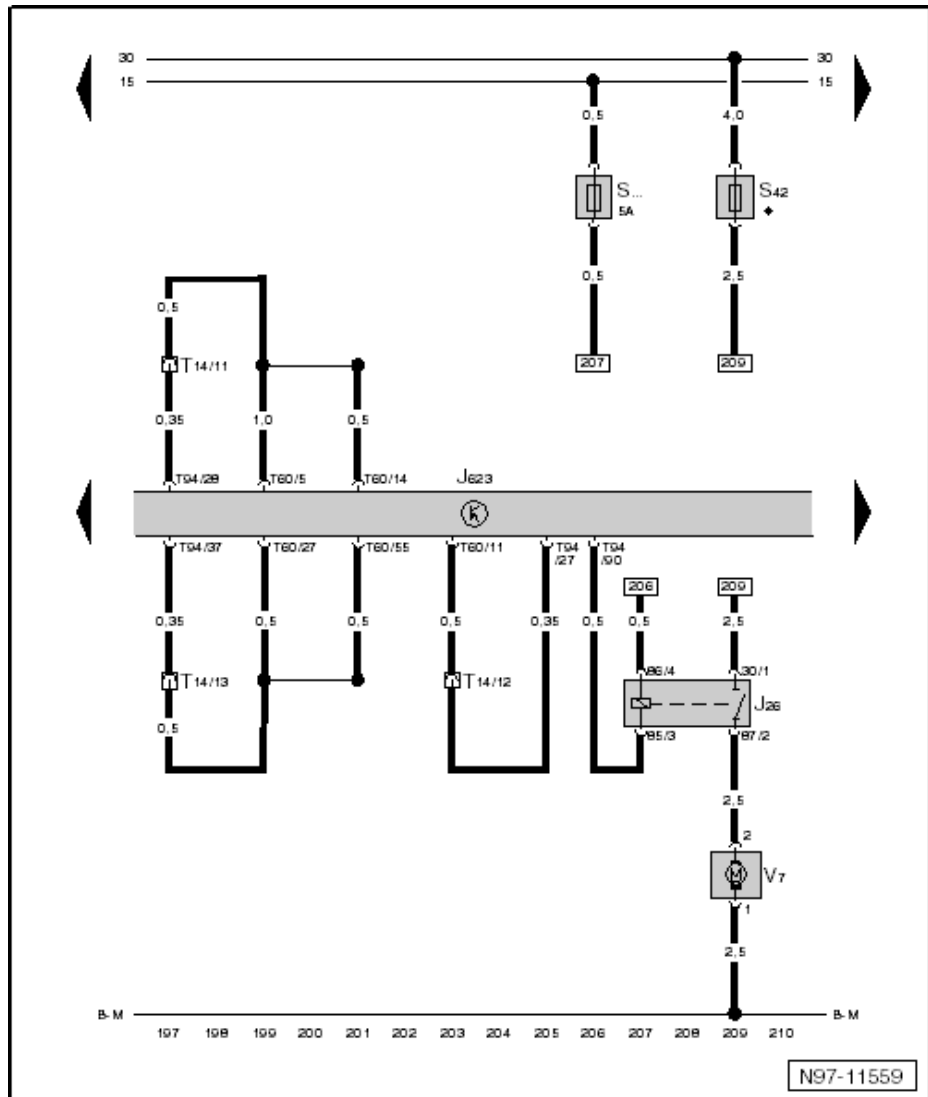



3.2.16 Diagnosis connection, oil pressure switch, engine control unit, oil pressure warning lamp

- F1** - Oil pressure switch
- J150**-Oil pressure monitor delay relay
 - * Customer specific
- J623**-Engine control unit
- K3**- Oil pressure warning lamp
- S...**- Fuse
 - 5 A
 - In fuse holder.
- T14**-14-pin connector
- T16**-16-pin connector
 - Diagnostic connection
- T94**-94-pin connector
 - * - Customer specific
 - ** - Output rev. signal
- B-M**-Battery earth/engine earth

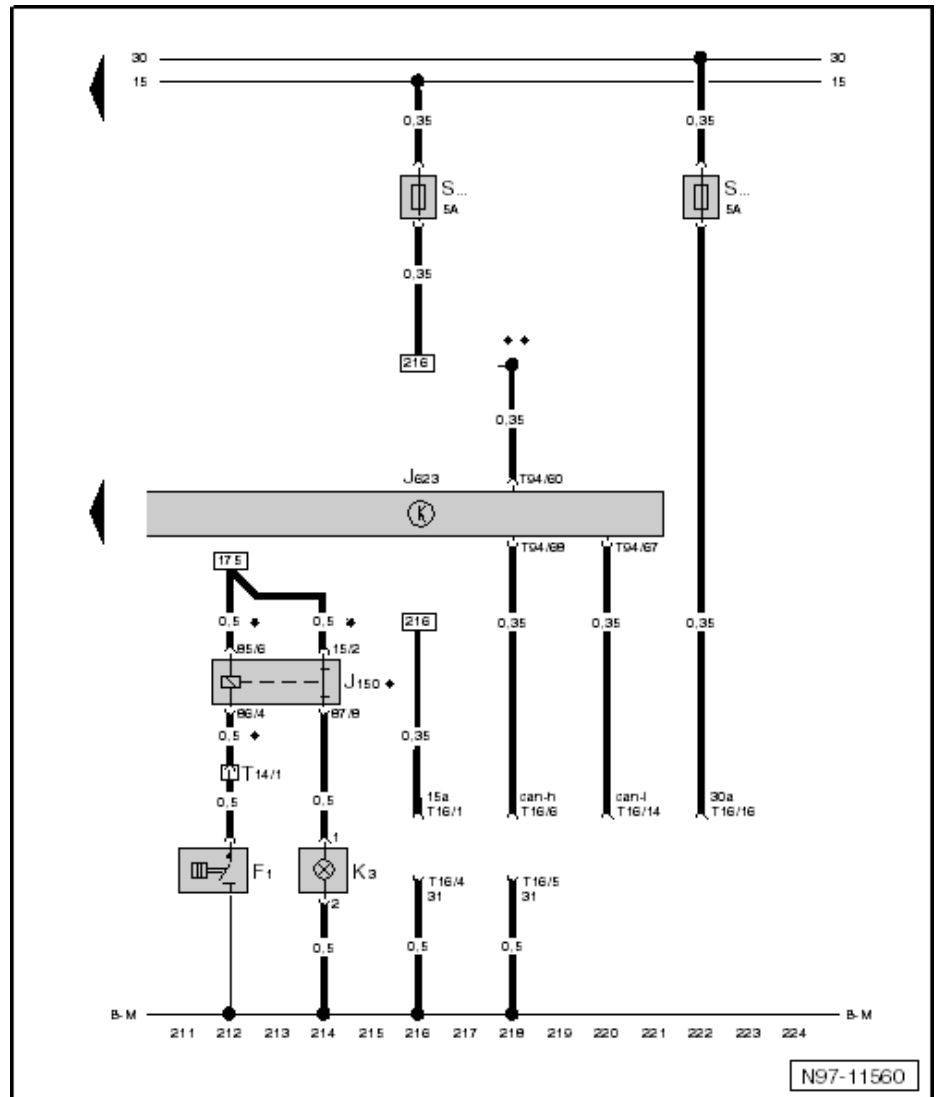



28 – Glow plug system

1 Glow plug system

Removing and installing, checking glow plugs ⇒ page 338.

1.1 Removing and installing, checking glow plugs

Special tools and workshop equipment required

- ◆ Jointed spanner -3220-

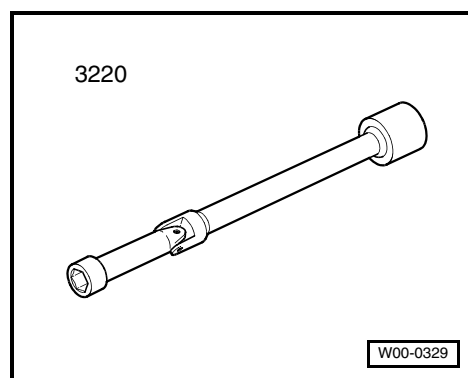

- ◆ Pliers -3314-
- ◆ Torque wrench (5...50 Nm) -V.A.G 1331-
- ◆ Hand multimeter -V.A.G 1526- or multimeter -V.A.G 1715-
- ◆ Adapter set -V.A.G 1594-
- ◆ Current flow diagram

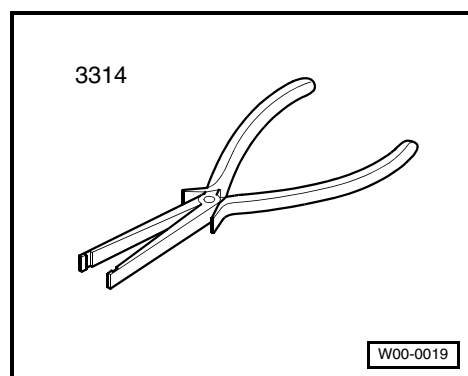

Test prerequisites

- Ignition switched off

Procedure

- Switch off ignition.
- Remove noise insulation from injectors.
- Pull connectors off injectors -A-, exhaust gas pressure sensor 1 -G450- -B- and common rail pressure sensor -C-.
- Unscrew securing bolts of coolant line -arrows- from intake manifold and set down coolant line in front of intake manifold.

⚠ Caution!

Ensure that no cable connections are damaged when pulling off connectors. Otherwise the complete wiring harness must be renewed. Do not compress the pliers -3314- to firmly to separate the connectors, otherwise the support sleeve may be damaged.

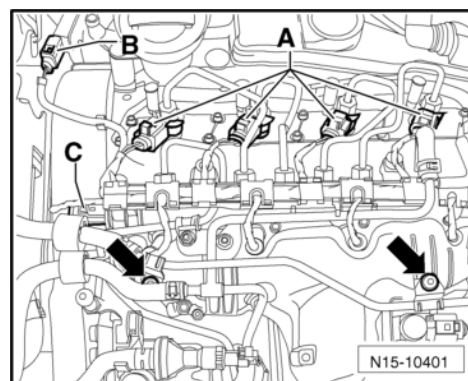



- Position pliers -3314- with groove -arrow A- on support sleeve shoulder -arrow B- and pull plugs off glow pin plugs.

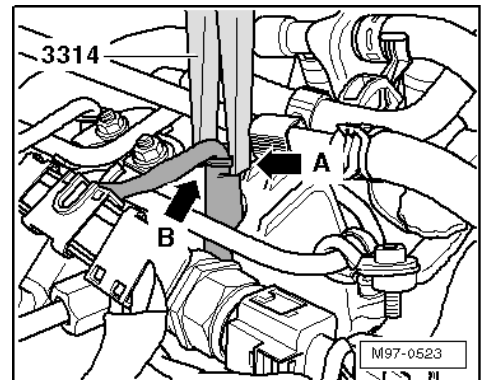

- Carefully pull connector off glow pin plug in direction of -arrow-.

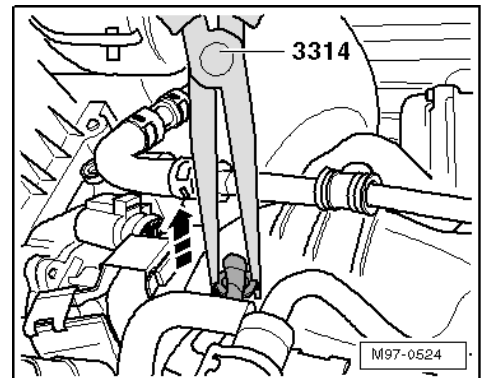

- Unscrew securing nut of fuel return line from intake manifold, open clamp -arrow- and pull line off fuel rail.

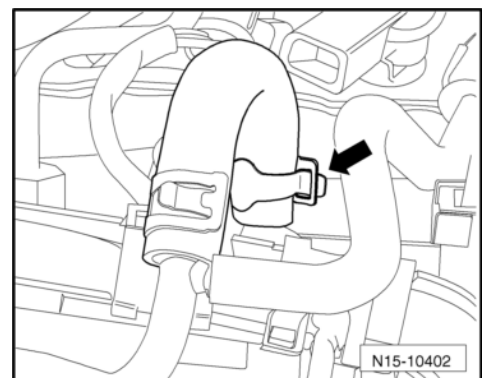

- Pull fuel return line connections off injectors. To do this, push down connection at tabs and pull up centre piece to release.

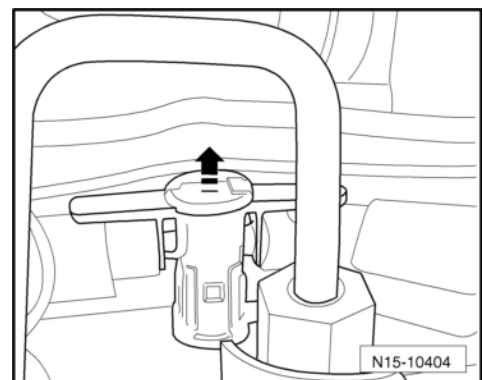

i Note

Adhere strictly to rules of cleanliness. No dirt must be allowed to get into the disconnected fuel return lines or the open connections on the injectors.

- Remove entire fuel return line and set it down in front of intake manifold.
- Remove cable duct and move to one side.
- Clean glow plug central opening in cylinder head, ensure no dirt gets into cylinder.

i Note

- ◆ *Cleaning procedure:*
- ◆ *Use a vacuum cleaner to remove coarse dirt.*



- ◆ *Spray brake cleaner or suitable cleaning agent into glow plug opening, let it work in briefly, and blow out with compressed air.*
- ◆ *Then clean glow plug opening using a cloth moistened with oil.*
- To loosen glow plugs use special tool U/J extension and 10 mm socket -3220-

Installing

- To tighten glow plugs use special tool U/J extension and 10 mm socket -3220- with a suitable torque wrench.
- Then tighten glow plugs to specified torque.
- ◆ Specified torque: 18 Nm
- Always perform a resistance test at all glow plugs after their installation and before starting the engine the first time (engine cold).
- Specification: max. 1.0 Ω
- If the specification is exceeded, renew the defective glow plug.
- Attach glow plug connectors correctly and make sure they are securely fitted.

Then finally clear the fault memory ⇒ [page 8](#).

